

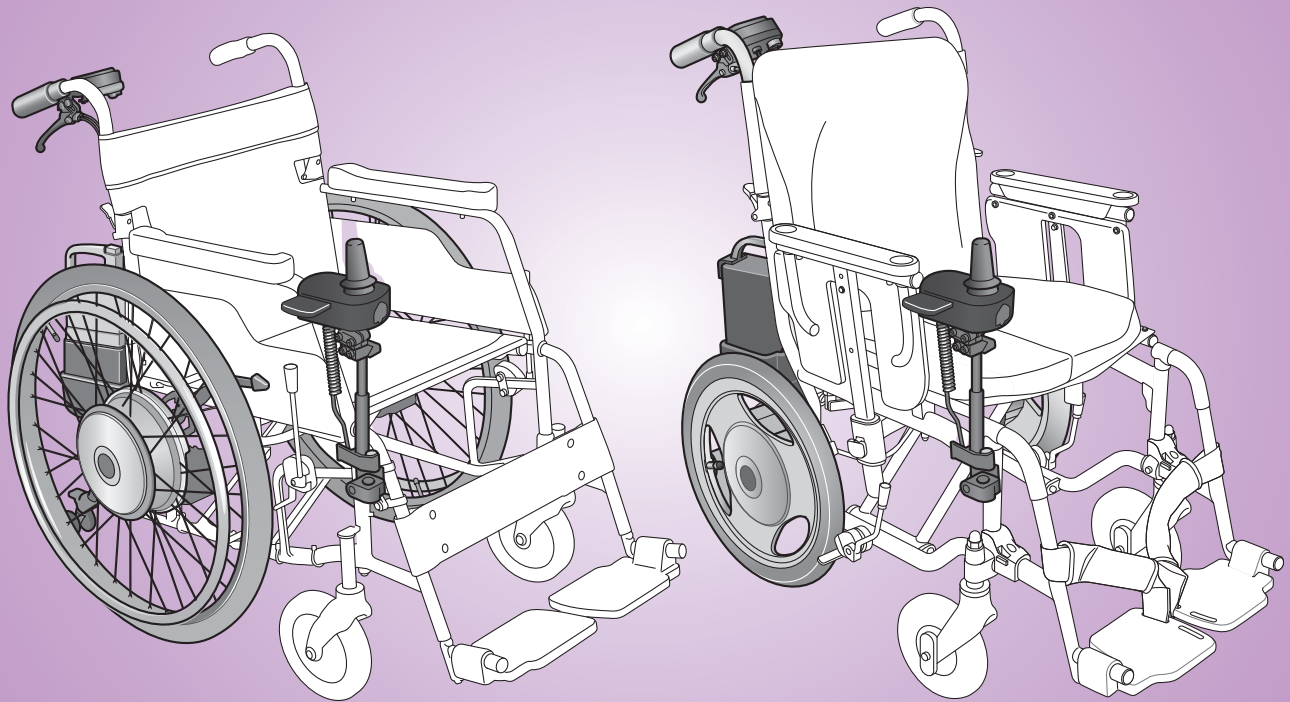



Electric Power Unit for Wheelchairs

# *iXpress*



## OWNER'S MANUAL

 Read this manual before using the product.

Read this manual carefully to ensure safe and comfortable operation.  
After reading it, store it where it can be accessed easily for future reference.



# Table of Contents

<b>1. Please Read Before Use</b>	<b>1</b>
1.1. Foreword	1
1.2. Symbols Used in This Manual	1
1.3. Operation Diagnosis Check	2
1.4. Assistive Operation Diagnosis Check	3
1.5. Warnings and Notes for the Operation	3
1.6. Warning Label Location Diagram	19
<b>2. Names of Parts</b>	<b>22</b>
2.1. iXpress 24"	22
2.2. iXpress 16"	23
2.3. Controller	24
2.4. Assistant Controller (Optional)	24
2.5. Nickel Metal Hydride Battery (JWB2)	25
2.6. Lithium Ion Battery (ESB1)	26
2.7. Charger for Lithium Ion and Nickel Metal Hydride Battery (ESC3)	27
<b>3. Before Sitting in the Wheelchair</b>	<b>28</b>
3.1. Inspecting the Wheelchair	28
3.2. Checking Your Clothing	31
3.3. Checking the Residual Capacity of the Battery and Installing the Battery on the Wheelchair	32
<b>4. Riding the Wheelchair</b>	<b>34</b>
4.1. Sitting in the Wheelchair	34
4.2. Moving the Wheelchair	36
4.3. Adjusting and Confirming the Maximum Speed	38
4.4. Checking the Residual Capacity of the Battery during Operation	39
4.5. Anti Theft Function	40
4.6. Other Functions	41
4.7. Practicing Basic Operations	42

## **5. After You are Finished Riding the Wheelchair 44**

**5.1. Getting Out of the Wheelchair 44**

**5.2. Removing the Battery 45**

## **6. How to Use the Assistant Controller 46**

**6.1. Getting in the Wheelchair 46**

**6.2. Starting Assistant Travel Mode 46**

**6.3. After Assistant Operations are Finished 49**

## **7. Handling the Batteries and Chargers 50**

**7.1. Types of Batteries 50**

**7.2. Maintenance 50**

**7.3. Warnings and Notes for Battery Handling 51**

## **8. Nickel Metal Hydride Battery and Charger 55**

**8.1. Features of the Nickel Metal Hydride Battery (JWB2) 55**

**8.2. How to Use the Nickel Metal Hydride Battery (JWB2) 55**

**8.3. Characteristics and Handling of the Nickel Metal Hydride Battery (JWB2) 57**

**8.4. How to Charge the Nickel Metal Hydride Battery (JWB2) 59**

**8.5. Refresh Charging the Nickel Metal Hydride Battery (JWB2) 63**

**8.6. Charger (ESC3) Indicator Lamps 64**

## **9. Lithium Ion Battery and Charger 67**

**9.1. Features of the Lithium Ion Battery (ESB1) 67**

**9.2. How to Use the Lithium Ion Battery (ESB1) 67**

**9.3. Characteristics and Handling of the Lithium Ion Battery (ESB1) 69**

**9.4. How to Charge the Lithium Ion Battery (ESB1) 72**

<b>9.5. The Temperature of the Lithium Ion Battery (ESB1) during Charging</b>	<b>76</b>
---	-----------

<b>9.6. Charger (ESC3) Indicator Lamps</b>	<b>77</b>
--	-----------

## **10. Wheelchair Transporting and Storing Instructions 78**

<b>10.1. Loading the Wheelchair in a Car</b>	<b>78</b>
--	-----------

<b>10.2. Unloading the Wheelchair from a Car</b>	<b>80</b>
--	-----------

<b>10.3. Storing the Wheelchair</b>	<b>81</b>
-------------------------------------	-----------

<b>10.4. Boarding an Airplane</b>	<b>82</b>
-----------------------------------	-----------

## **11. Using the Wheelchair more Comfortably 83**

<b>11.1. Removing and Installing the Unit</b>	<b>83</b>
---	-----------

<b>11.2. Anti-tip Device</b>	<b>86</b>
------------------------------	-----------

<b>11.3. Controller Holder</b>	<b>88</b>
--------------------------------	-----------

<b>11.4. Assistant Controller (Optional)</b>	<b>94</b>
--	-----------

<b>11.5. Clutch Levers</b>	<b>94</b>
----------------------------	-----------

<b>11.6. Parameter Settings</b>	<b>94</b>
---------------------------------	-----------

<b>11.7. Smart Tune Settings</b>	<b>96</b>
----------------------------------	-----------

## **12. Maintenance, Daily Check, Periodic Inspection 98**

<b>12.1. Maintenance</b>	<b>99</b>
--------------------------	-----------

<b>12.2. Daily Checks</b>	<b>101</b>
---------------------------	------------

<b>12.3. End of JWX-1 PLUS Use Recycling</b>	<b>101</b>
--	------------

## **13. Specifications 102**

## **14. Troubleshooting, Repairs, Warranty 104**

<b>14.1. Before Requesting Repairs</b>	<b>104</b>
--	------------

<b>14.2. Requesting Repairs and Inspections</b>	<b>108</b>
---	------------

<b>14.3. Serial Number Location</b>	<b>108</b>
-------------------------------------	------------

<b>14.4. Warranty</b>	<b>108</b>
-----------------------	------------

## Introduction

This is a manual for the “iXpress” electric power unit for wheelchairs. Before you read this manual, check which product you are using.

This product consists of the left and right drive units, the joystick-equipped controller, the battery, optional battery bag, the battery charger, and the optional assistant controller. These components, except for the battery and charger, are already installed to the wheelchair frame. For the initial use, the customer does not have to use tools, and so on, to assemble the wheelchair. Refer to “2. Names of Parts” to ensure that these components are installed to the wheelchair that you purchased and that the battery and charger are included. If you visually notice that any of these components are not installed, are not included, or are damaged before using the wheelchair, immediately contact the dealer without using the wheelchair.

**iXpress 24"**

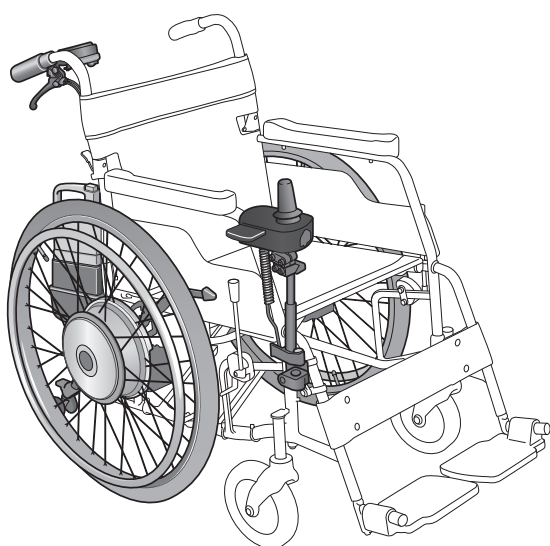

**iXpress 16"**

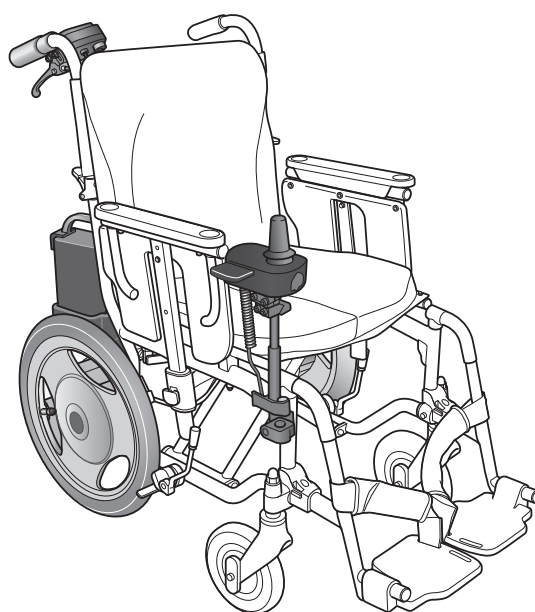

For information for operating the wheelchair frame and warranty for the frame with which you are using the iXpress, see the frame manual.



The iXpress and its accessories comply with the applicable sections of standard EN12184 for electric wheelchairs and comply with the EU Medical Devices Regulation (EU) 2017/745.



### **WARNING**

- **Read and understand this manual completely before operating your iXpress product. This manual should be considered a permanent part of your product and should remain with it.**

# 1. Please Read Before Use

## 1.1. Foreword

Thank you for purchasing the iXpress.

Indication for use: The device iXpress is a Powered Wheelchair Conversion Kit and suit-able for a disabled person who cannot walk or has restrictions on walking. It is intended for medical purposes to provide a means for a disabled person to take over the propulsion of the wheelchair and increase mobility and flexibility.

Generally speaking, riding in a wheelchair incurs the possible risk of personal injury or damage to the wheelchair from improper use. Depending on the type or extent of the disabilities of the user, it might be dangerous to travel unaccompanied.

Before using the wheelchair, be sure that not only the user, but also the assistant and controller, has read this manual to assure full understanding.

- (1) The wheelchairs on which the iXpress has been installed are wheelchairs for physically handicapped people, and their legal status is that of a pedestrian. Make sure to adhere to the traffic rules and manners of a pedestrian.
- (2) The iXpress 24" withstands a load of 125 kg. Use with a total maximum load including the chairframe weight of 125 kg. The iXpress 16" withstands a load of 100 kg. Use with a maximum load of 100 kg. If the frame on which the iXpress is installed has an even lighter load capacity, ensure that you do not exceed that value.
- (3) To ensure safe use, warning labels are affixed to this product. Make sure to adhere to the warning labels. Refer to "1.6. Warning Label Location Diagram" for the locations of the warning labels.
- (4) Do not use this product for any purpose other than as an electric wheelchair.
- (5) Some of the illustrations in this manual are images of general electric wheelchairs. The actual product may be different than that shown.

## 1.2. Symbols Used in This Manual



Indicates safety-related cautionary information.



**WARNING**

Indicates that misuse may lead to fatal or severe injury, or disability.

**NOTICE**

Indicates that misuse may lead to material damage.



Indicates things you must not do.

**TIP**

Indicates correct methods and key points when operating the product.

## 1.3. Operation Diagnosis Check

Depending on the extent of your disabilities, it may be dangerous to travel unaccompanied. Use this diagnosis check as a guide to determine whether or not you can travel unaccompanied.

### WARNING

- **Before using the wheelchair, be sure to assess your competence and determine whether or not you need an assistant. Moreover, in determining the necessity of an assistant, consult expert opinions as a point of reference. If your judgment is based solely on your own opinion, you or other people around you may get injured.**

#### Diagnosis Check

- (1) Are you able to move the switches on the controller at your own will?
- (2) Are you able to tilt the joystick forward slowly and move smoothly?
- (3) Are you able to move the joystick back to original position?
- (4) Are you able to tilt the joystick in the direction you want to go?
- (5) Are you able to correctly perceive visually the conditions of the road surface and your surroundings, and avoid dangerous areas?



Can operate all items.

Have trouble operating one or both.

Use this product by having an assistant provide assistive operation.

You can travel unaccompanied. For your safety, remember to travel carefully. In situations such as those mentioned in the warnings in “1.5. Warnings and Notes for the Operation”, be sure to have an assistant accompany you, and pay sufficient attention to safety while traveling.



## 1.4. Assistive Operation Diagnosis Check

Use the diagnosis check below as a guide to determine whether or not you can provide assistive operation.

### WARNING

- If an assistant is to accompany you and operate the wheelchair, be sure to assess his or her competence. Moreover, when assessing the assistant's competence, consult expert opinions as a point of reference. If your judgment is based solely on your own opinion, you or other people around you may get injured.
- If you lack the competence to provide assistive operation, do not attempt to provide it.

1

### Diagnosis Check

If you feel uncomfortable with any of the 3 tasks below, do not provide assistive operation.

- (1) Are you able to correctly perceive the conditions of the road surface and your surroundings, and avoid dangerous areas?
- (2) Are you able to assist the user to get on and off the wheelchair, and to replace the battery?
- (3) Are you able to provide assistive operation on a manual wheelchair?

## 1.5. Warnings and Notes for the Operation

Please read this manual before using the product.

Please read this manual carefully to ensure safe and comfortable operation. After reading it, store it where it can be accessed easily for future reference.

Unless specifically noted, the following information applies to when the user is operating the wheelchair themselves and when an assistant is operating the wheelchair using the assistant operations.

### 1.5.1. Before Using the Wheelchair After Purchasing the Unit

### WARNING

- Before using the wheelchair, be sure to assess your competence and determine whether or not you need an assistant. Moreover, in determining the necessity of an assistant, consult expert opinions as a point of reference. If your judgment is based solely on your own opinion, you or other people around you may get injured.
- Practice traveling on a level and safe area with an assistant accompanying you, until you are comfortable with the operation. If you go on public roads while still unfamiliar with the operation, you or other people around you may get injured.

## 1.5.2. Before Use Each Day

### WARNING

- Perform the daily checks before use every day. Make a habit out of inspecting the wheelchair. Continued use of the wheelchair with a problem in the wheelchair body or the wheels may cause damage to the wheelchair while traveling, and may result in a rollover or fall.

- Before using the wheelchair each day, ensure that there is air in the tires. Always keep the air pressure in the rear tires at a normal level. If the air pressure in the rear tires decreases, the parking brakes may become ineffective.

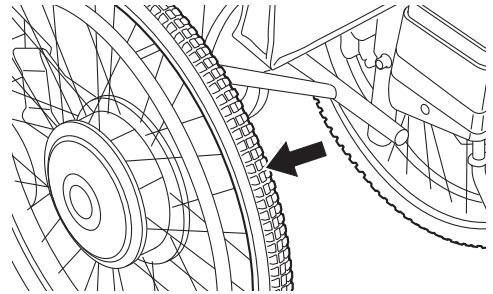

- Before using the wheelchair each day, ensure that the anti-tip devices are in the correct position. If the anti-tip devices are not in the correct position, the wheelchair could fall backward.

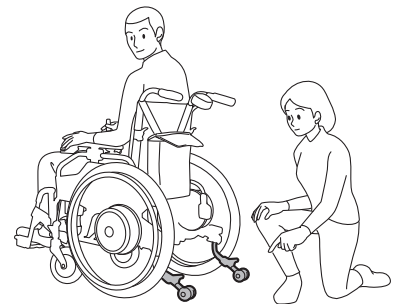

- Before using the wheelchair each day, check the residual capacity of the battery. If the residual capacity of the battery is low, the battery may run out during operation and it may become impossible to travel in power drive mode.

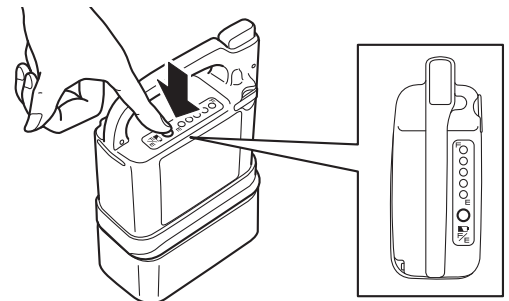

### 1.5.3. Handling the Wheelchair

#### WARNING

- Modifying the unit or its mounting may adversely affect its performance and safety. Never make any modifications.
- If the wheelchair has parts that are foldable or detachable, do not operate the wheelchair with those parts folded or removed.
- When lifting the wheelchair, do not hold movable parts.

- Do not operate with any heavy baggage hanging over the backrest, or with any heavy objects in the compartment. The wheelchair could easily fall backward on an inclined slope, and may cause you or people around you to get injured.



- The wheelchair may tip over if it is operated with the anti-tip devices removed, folded, or with the safety wheels facing upwards. Be sure to set the anti-tip devices correctly and operate the wheelchair with the safety wheels in the correct position.

- Do not connect any electric instruments to the plug on the joystick. This plug is to connect a PC for the Smart Tune software. Plugging other electric instruments like audio microphone or earphones may cause unit trouble. About the Smart Tune software, refer to “11. Using the Wheelchair more Comfortably”.

- Do not hang anything on the joystick on the controller. It may get in the way of your operation, or the weight of the object may prevent the joystick from returning to its original position, even after your hand has released it. In addition, if you put a rubber band around the joystick, it may get jammed inside the controller, causing the joystick to not return to its original position. In either case, there is a risk of the wheelchair not stopping.

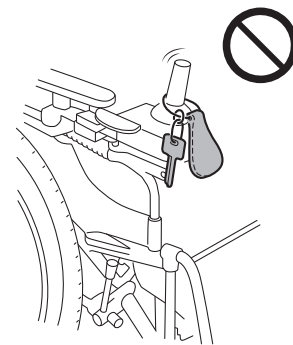

- Do not receive microwave thermotherapy while seated in the wheelchair.

The microwaves may result in drive unit malfunctions, accidental operations and heated metal parts causing burns. Switch off the power to motorized wheelchairs and place them away from microwave thermotherapy equipment.

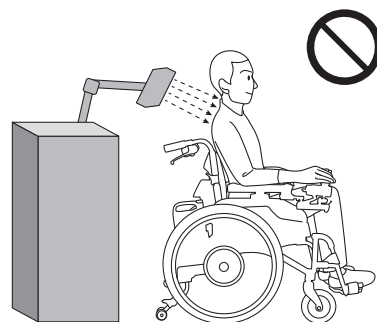



## WARNING

- In areas with an incline, do not switch the clutch levers to the manual position. The wheelchair may start moving unexpectedly, and may collide or tip over.

- Do not operate the clutch levers while the wheelchair is in motion. There is a risk of collision or tipping over.

If you switch the clutch levers to the manual position while traveling in power drive, the motor brake loses its effect and the wheelchair may go out of control.

If you switch the clutch levers to the power drive position while traveling in the manual drive, brakes are applied to the rear tires. This abrupt braking can cause your body to plunge forward or damage the wheelchair.

- Removing the battery while traveling causes the brakes to be applied to the rear tires, and may cause you or people around you to get injured.
- Turning off the power switch while traveling causes the brakes to be applied to the rear tires, and you or people around you may get injured.

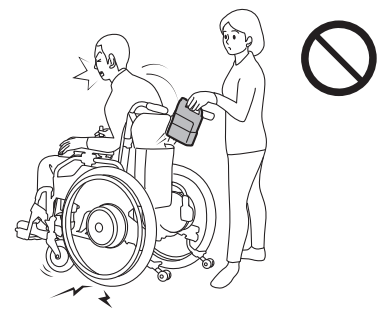

- While the wheelchair is being operated or after operation, do not touch the back of the drive units. During or after operation, the back of the drive units may be hot. In addition, if the wheelchair is near a source of heat, the drive units may become hot.

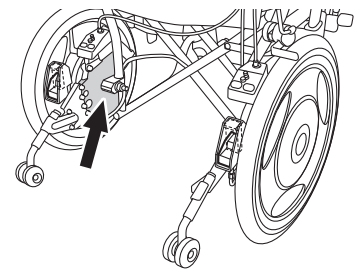

- While operating the wheelchair, be careful not to get your hands tangled in the wheel spokes, wheel holes, etc.



- The wheels of the iXpress 16" are not equipped with hand rims. When operating the iXpress 16", do not manually drive the wheelchair by holding its rear tires or wheels. You may injure yourself.

- When moving past hedgerows and trees, maintain a suitable distance to prevent the rear wheels from coming into contact with twigs or other protruding items. If twigs or other items from hedgerows and trees get caught in the rear wheels when operating the wheelchair, it may result in the wheels becoming locked, the clutch lever being knocked into the manual position, collisions or the wheelchair tipping over.

#### 1.5.4. Getting In/Out of the Wheelchair, Seating

##### WARNING

- When getting in the wheelchair by yourself or when the assistant has the user of the wheelchair get in the wheelchair, ensure that the wheelchair is on a level ground. If the user attempts to get in the wheelchair on an incline, he or she may lose balance and fall off the wheelchair.



- To switch the clutch levers to the manual position, such as when starting assistant operations, apply the parking brakes on a level and stable ground, and then with the power turned off, switch the clutch levers.
- If you are using a wheelchair with no parking brakes, have the assistant hold the wheelchair to ensure that it does not move. Failure to observe the above may cause the wheelchair to start moving unexpectedly, and may result in you or people around you to get injured.
- Do not lean out of the wheelchair to retrieve an item. Otherwise, you could fall off the wheelchair or the wheelchair could tip over.

#### 1.5.5. General Operation

##### WARNING

- Never ride the wheelchair with two people. The wheelchair may malfunction or the people riding it may get injured.



- Never operate the wheelchair after consuming alcohol or taking medicine that causes drowsiness.
- Never operate the wheelchair while holding an umbrella or other items.
- Never tow the wheelchair. Do not use the wheelchair to tow or pull anything.



## WARNING

- If you want to use a portable phone, etc., stop the wheelchair at a safe place and turn off the wheelchair. Moreover, while traveling in power drive, keep portable telephones and other electronic devices turned off. Otherwise, there is a risk of an accident.



- Do not operate the wheelchair near a device that produces strong radio waves. If the wheelchair is near a source of radio waves and starts to operate abnormally, immediately turn off the power, and quickly move away from that location using the assistant operations or manual operation. The weak electromagnetic waves emitted iXpress may affect other electronic devices, such as automatic doors and the anti-theft systems of stores. In this case, turn off the power and operate the wheelchair using the assistant operations or manual operation.

- Do not turn the power switch off while traveling. It causes the brakes to be applied to the rear wheels in some cases and may cause you to fall down from the wheelchair.

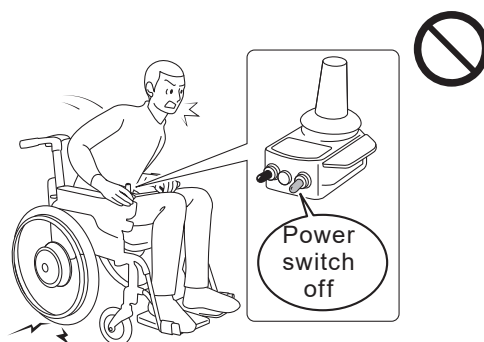

- Do not use the wheelchair for transporting luggage or for any other purpose than to provide assistance to a disabled person.

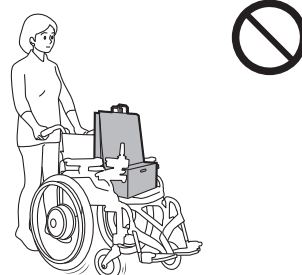

**! WARNING**

- Do not ride with clothing that is unsafe for wheelchairs, such as shown below. If you drive with such clothing, you or other people around you may get injured.

Long scarves



Clothing with loose sleeves

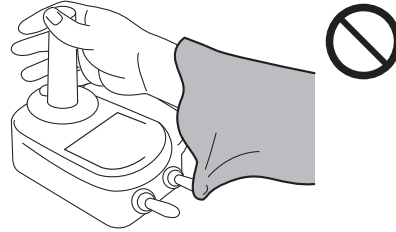

Pants/skirts with wide hems

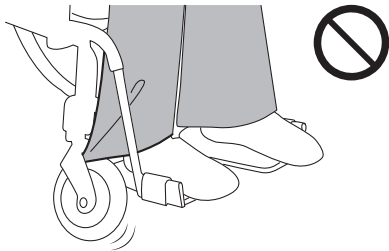

Bare feet, sandals, slippers, ill-fitting footwear, etc.

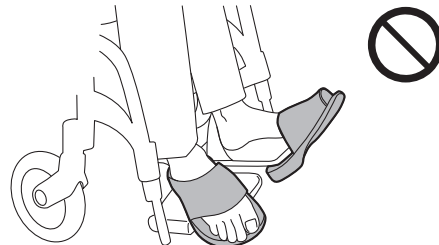

In the following environments and situations, you may need an assistant to accompany you and to operate the wheelchair for you.

In such cases, have an assistant accompany you. Traveling alone in these situations may lead to injury.

Moreover, check to see if any dangers such as those shown below exist in the roads you use on a daily basis. If so, select a route that does not pass through such areas.

Always check the surrounding conditions to ensure safety.

## 1.5.6. Operation on Public Roads



### WARNING

- When the wheelchair is operated outdoors, its legal status is that of a pedestrian. Make sure to adhere to the rules and manners of a pedestrian.
  - On general roads, be careful of automobiles, bicycles, and pedestrians. Be sure you do not run into pedestrians.
- 
- Although the wheelchair can be operated on pedestrian-only roads, it cannot be operated where pedestrians are not allowed (car roads, in the middle of a road, etc.).
  - If the road has a sidewalk, operate the wheelchair on the sidewalk.
  - If the road does not have a sidewalk, operate the wheelchair on the side strip of the road where pedestrians walk.
  - If the road does not have a side strip, operate the wheelchair on the side of the road where pedestrians walk.
- 
- If two or more wheelchairs are traveling together outdoors, the wheelchairs should be operated in a single line with sufficient space between the wheelchairs. The wheelchairs should not be operated side by side.
- 
- When starting off or moving backward, be careful of other people and obstacles around you.
- 
- It is extremely dangerous to travel on a narrow street without a sidewalk. Choose a safer path whenever possible.
- 
- Be careful not to travel too close to the edge when traveling on an embankment, etc., of a road. Depending on the condition of the shoulder of the road, you could accidentally move off the road.
- 
- 
- When traveling on a sidewalk that does not have a guardrail, there is a risk of falling into the street side. Have an assistant accompany you instead of traveling alone.
- 
- When traveling near a ditch, the tire may fall into it if there is a gap even if it is covered. Have an assistant accompany you instead of traveling alone.
- 
- If there are any obstacles, stop the wheelchair and check in front of you and behind you for safety before proceeding.



**! WARNING**

- If an oncoming vehicle is near, stop the wheelchair, wait for the vehicle to pass, and then check in front of you and behind you for safety before proceeding.

- Do not operate the wheelchair outdoors at night. Not being able to see the road conditions, you may lose balance and fall, or people or cars may collide into you if they cannot recognize you.

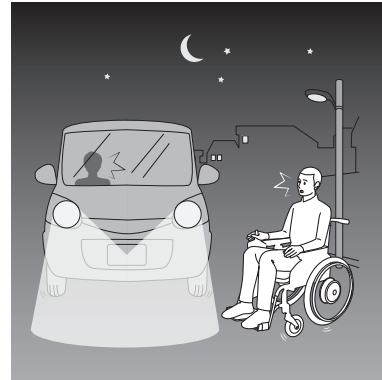

- If it is raining or snowing, do not operate the wheelchair outdoors. Automobiles and other vehicles may collide into you if they cannot recognize you. If it starts to rain or snow while you are outdoors, move indoors as soon as possible.

**1.5.7. Operation on Slopes**

**! WARNING**

The wheelchairs equipped with the iXpress are built to be lighter compared to other heavier electric wheelchairs that use a heavier general lead battery. For this reason, when a person sits in it, the overall center of gravity may be different. Therefore, use caution when traveling on a slope.

- Do not use the wheelchair on a slope steeper than 6 degree (10% grade). It may tip over or the brake may become ineffective.

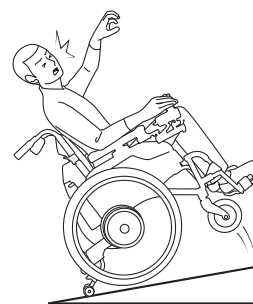

- When going up/down a particular slope for the first time, have an assistant accompany you to ensure safety.
- In areas with an incline, do not switch the clutch levers to the manual position. The wheelchair may start moving unexpectedly, and may collide or tip over.



## WARNING

- Do not abruptly turn on a downhill slope. In addition, do not traverse horizontally or diagonally across a steep slope. You could easily lose balance and tip over.
- On a downhill slope, start the braking operation early. The braking distance on a downhill slope may be significantly longer than when traveling on level ground.

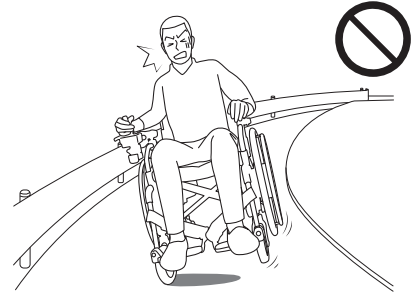

- In the areas where the wheelchair leans sharply to the left or right, the wheelchair may tip over sideways. Have an assistant accompany you.



- When descending down a slope with the assistant operations, descend in reverse. If the assistant moves the wheelchair forward when descending, the passenger may plunge forward and fall off the wheelchair.

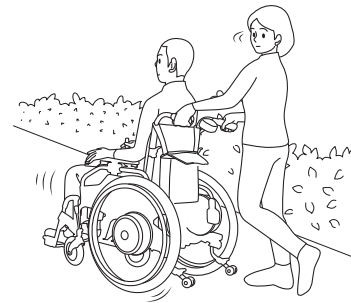

### 1.5.8. Going Up/Down Curbs



## WARNING

The wheelchairs equipped with the iXpress are built to be lighter compared to other electric wheelchairs that use a heavier general lead battery. For this reason, when a person sits in it, the overall center of gravity may be different. Therefore, use caution when traveling on a curb.

- When traveling in power drive mode, the wheelchair can clear level differences of approximately 1 inch (25 mm) (varies depending on the caster size). Any greater level differences should be cleared by an assistant by manual push operation.
- When going up/down a curb for the first time, have an assistant accompany you instead of traveling alone.



## WARNING

- When traveling over a curb, be careful not to lose your balance.
- When traveling over a curb, proceed at a right angle to the curb. Do not traverse the curb diagonally.
- Because the front casters are small, they are able to travel over only small curbs. Therefore, caution is necessary when traveling over curbs in power drive mode.
- When traveling between a sidewalk and a road, be careful of curbs.
- To travel over a curb or other obstacles with the assistant operations, turn off the assistant controller and go over it manually. If the assistant goes over a curb or other obstacles in power drive mode, the assistant could easily lose balance and the passenger or assistant could get injured if the wheelchair tips over.
- When descending from a curb with the assistant operations, descend in reverse. If the assistant moves the wheelchair forward when descending, the passenger may plunge forward and fall off the wheelchair.
- When going up/down a curb with the assistant operations, the safety wheels of the anti-tip device may be raised or folded temporarily depending on the height of the curb. After traveling over the curb, be sure to place the safety wheels of the anti-tip devices in the correct position before operating the wheelchair.

1

### 1.5.9. Crossing Roads



## WARNING

- You cannot cross a road where pedestrians are prohibited from crossing.
- When crossing at an unfamiliar location, have an assistant accompany you.
- If the residual capacity of the battery is low, the wheelchair may stall while crossing a street. Check the residual capacity of the battery before crossing.
- Before crossing a road, be sure to check to the left and right for safety.
- Do not cross a road if it is dangerous to do so, such as if an automobile is approaching.
- When crossing a road, proceed as close as possible at a right angle to the road. Do not cross the road diagonally.
- Cross a road at a location where there is a traffic light or crosswalk.



## WARNING

- When crossing a street at a crosswalk with no traffic light, pay sufficient attention to the traffic.
- If there is a pedestrian signal light, obey the signal light. If the signal light is flashing green or is red, you must not start to cross the road.
- If the street is wide, the signal may change before you finish crossing. In such places, wait for the next green light to give yourself enough time to cross the street.
- At intersections where there are no traffic lights or crosswalks, stop in the following three stages.
  1. Stop before entering the road.
  2. Stop where you can be seen by automobiles.
  3. Stop where you have a good view of the road.

### 1.5.10. Railroad Crossings



## WARNING

- Avoid railroad crossings if you can go around them.
- If you have no choice but to travel over a railroad crossing, have an assistant accompany you.
- Be sure to stop before the railroad crossing and check to the left and right for safety.
- When traveling over a railroad crossing, proceed as close as possible at a right angle to the railroad tracks. If you travel diagonally, the wheelchair casters may get caught in the railroad tracks.
- Be careful not to travel too close to the edge when traveling over a railroad crossing. Otherwise, the wheels could accidentally move off the railroad crossing. If case of an emergency, do not panic. Have the assistant or a person around you switch the clutch lever to the manual side and move off the railroad crossing as quickly as possible.

## 1.5.11. Poor Road Conditions

### WARNING

The wheelchairs equipped with the iXpress are built to be lighter compared to other electric wheelchairs that use a heavier general lead battery. For this reason, when a person sits in it, the overall center of gravity may be different. Therefore, use caution when traveling on uneven surface.

- Do not travel on gravel roads, bumpy roads, muddy roads, footpaths, etc. If you have no choice but to travel on such roads, have an assistant accompany you.



- Do not drive the wheelchair on a frozen surface. You may not be able to stop the wheelchair.

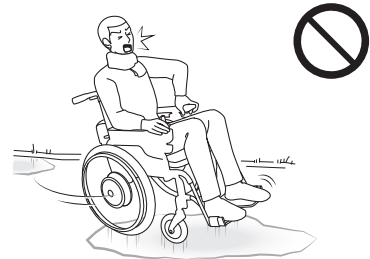

- Go around locations where snow or water has accumulated or have an assistant accompany you. In such places where you do not know the road conditions or if the wheelchair slips, you could lose control or the brakes may become ineffective. If the wheelchair travels through a deep puddle and water enters the drive units, the wheelchair could stop.



- If you see a dip in the road, or if a sidewalk dips due to a car ramp, go around it. If you go straight into it, the wheelchair may tip over. If you have no choice but to keep going, do so with an assistant accompanying you to ensure safety.

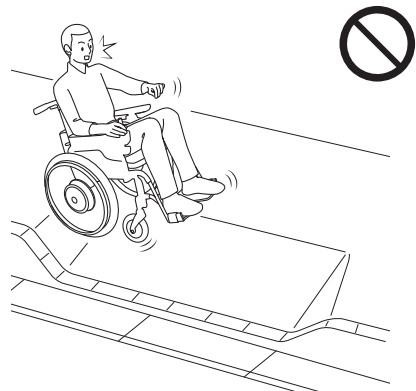

### 1.5.12. Parking Lots



#### WARNING

- Do not travel directly behind or in front of automobiles in parking lots. Drivers may not be able to see you if you are directly behind or in front of their automobiles.
- Do not travel between automobiles in parking lots. Otherwise, you could damage the automobiles or be crushed when an automobile starts moving.

1

### 1.5.13. Using Public and Private Transportation



#### WARNING

- When using public transportation, check to ensure that wheelchair use is allowed beforehand. In addition, follow the rules and instructions when boarding the vehicle.
- When using a private automobile, do not use the wheelchair as a seat. Sit in one of the automobile's seats.
- When getting on/off a lift vehicle, always have an assistant accompany you to ensure safety.

- When using a train station, always have an assistant accompany you, stop the wheelchair on the train station platform so that it is parallel to the railroad tracks, and be sure to apply the parking brakes. Some train station platforms are positioned at a slight angle to the railroad tracks. In some cases, you could fall onto the tracks and be injured.

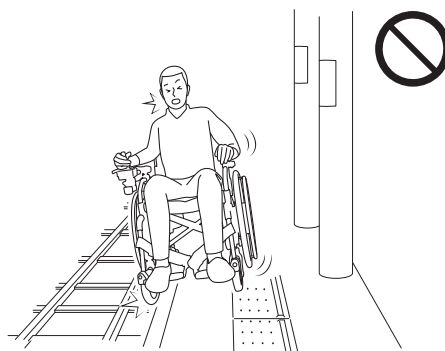

- When getting on/off a bus or train, always have an assistant accompany you to ensure safety.
- Whenever you get off a bus, a taxi, or a train, be sure that the safety wheels on the anti-tip device are in the correct position before getting in the wheelchair.

### 1.5.14. Crowded Areas

#### WARNING

- When getting in the wheelchair in a crowded area, do so with sufficient attention to your surroundings. If you bump into people or objects, your body may plunge forward, or people around you may get injured.
- When you are stopped in a crowded area, be sure to turn off the power. If a person in your surrounding area hits the joystick with his or her hand or arm, the wheelchair may start moving unexpectedly, causing injury to people around you.

1

### 1.5.15. Transporting and Storing the Wheelchair

#### WARNING

- When lifting a wheelchair with tilt-up arm support, never lift it by the arm support. Otherwise, the arm support may come off and cause an injury or damage to the equipment.
- When lifting a wheelchair, never lift it by the battery, cable, or controller. Otherwise, any of these devices may come off and cause an injury or damage to the equipment.
- Do not turn the wheelchair upside down. Doing so may cause parts of the wheelchair to fall off, resulting in an injury or damage to the equipment.
- During transport, do not place the battery or the wheelchair in a place that can become hot, or in direct sunlight. This could lead to malfunction, or could cause the deterioration of the battery to progress rapidly.
- Be sure to remove the battery when not in use, so that its power will not turn on unexpectedly in storage or during transport.
- Be sure to store the disconnected battery with the protective cap on it. Exposed contacts can cause short circuits and lead to a fire or battery rupture.
- Do not store in places that can get wet by rain, or that are high in humidity.
- Do not store when it has been wet for a long time, or there is dirt on it. This can cause malfunction.

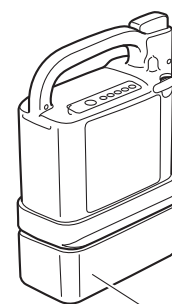

Protective cap

**WARNING**

- Avoid storing in direct sunlight or in places where the temperature can get high.
- Do not wash by directly hosing it down with water. Also, do not wash with using steam. The electronic devices can get damaged, which may lead to malfunction.
- Do not clean with solvents such as gasoline or paint thinner. This may damage the painting and plastic parts.

**1.5.16. Assistant Operations in an Emergency****WARNING**

- During assistant operations in case of an emergency, the assistant should switch the clutch levers to the manual position, and move the wheelchair to a safe location.



# 1.6. Warning Label Location Diagram

- Power Unit and Controller  
iXpress 16"

1

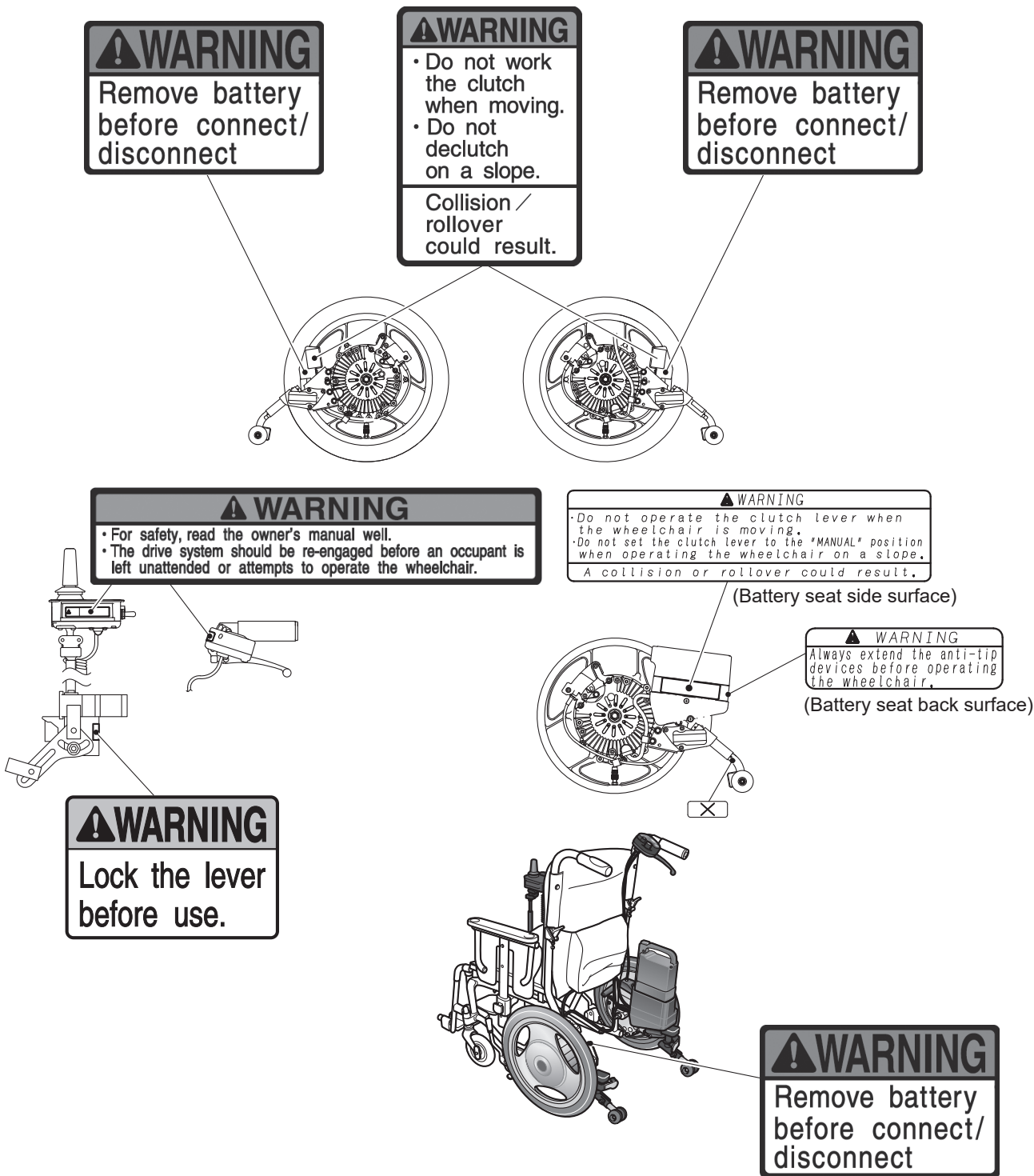

# JWX-1 PLUS 24"

1

**⚠ WARNING**  
• For safety, read the owner's manual well.  
• The drive system should be re-engaged before an occupant is left unattended or attempts to operate the wheelchair.

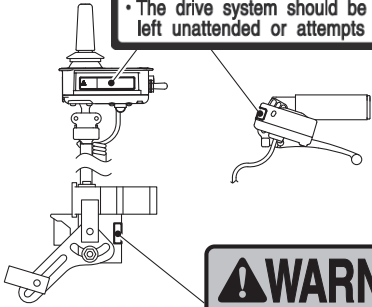

**⚠ WARNING**  
Lock the lever before use.

**⚠ WARNING**  
• Do not operate the clutch lever when the wheelchair is moving.  
• Do not set the clutch lever to the "MANUAL" position when operating the wheelchair on a slope.  
A collision or rollover could result.

(Battery seat side surface)

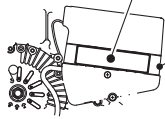

**⚠ WARNING**  
Always extend the anti-tip devices before operating the wheelchair.

(Battery seat back surface)

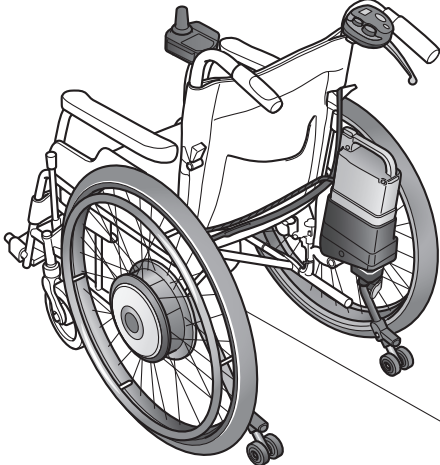

**⚠ WARNING**  
Remove battery before connect/disconnect

• **Lithium Ion Battery**

**NOTICE** Fold this grip down before riding.

**WARNING** Be careful not to pinch your fingers.

(Back side)

**WARNING**

- Charge with specified charger and use for specified wheelchair only.
- Do not disassemble or modify.
- Do not place near flames, submerge in water, or short-circuit terminals.
- Do not use battery if dropped or subjected to shocks.
- Remove battery before transporting wheelchair in motor vehicle.
- When not in use, cover terminals with protective cap.

**Overheating, rupturing, or fires could result.**

**Li-ion 22** 25.2V  
**DRY BATTERY** 10.08Ah  
 71NR19/66-6 254Wh  
 MADE IN JAPAN Typ. 10.68Ah

1

• **Nickel Metal Hydride Battery**

**WARNING** Do not use this handle to lift the wheelchair

**WARNUNG** Diesen Handgriff nicht zum Anheben des Rollstuhls benutzen

**YAMAHA**

**WARNING**

- Charge with specified charger and use for specified wheelchair only.
- Do not disassemble or modify.
- Do not place near flames or short-circuit terminals.
- Do not place in water, drop or subjected to shocks.
- Remove battery before transporting wheelchair in motor vehicle.
- When not in use, cover terminals with protective cap.
- Use only the specified fuse.

**Overheating or rupturing could result.**

**Ni-MH** 24V  
 6.7Ah  
 (5hr)

• **Ni-MH and Li-ion combined Charger (ESC3)**

**BATTERY CHARGER**  
 제품명칭: 충전기/充電器  
 MODEL / 모델명 / 型號: JWC-3  
**Ni-MH**

INPUT / 입력전압 / 輸入: 100V-240V ~ (額定電壓)  
 50/60Hz 0.91A-0.42A  
 OUTPUT / 출력전압 / 輸出規格: 29V --- 2.6A

**WARNING**  
 Before charging, read the owner's manual.  
 Indoor use only.  
 Charge only YAMAHA JWB2 Ni-MH rechargeable batteries.  
 To reduce risk of injury and/or equipment damage, do not use other battery types.  
 Don't use the charger if the input plug does not fit the power outlet.

**AVERTISSEMENT**  
 Avant de charger, lisez le manuel d'utilisation.  
 Usage intérieur seulement.  
 Ne chargez que des batteries rechargeables YAMAHA JWB2 Ni-MH.  
 Pour réduire les risques de blessures et/ou de dommages matériels, n'utilisez pas d'autres types de batteries.  
 N'utilisez pas le chargeur si la fiche d'entrée ne correspond pas à la prise de courant.

**警告**  
 ご使用前には必ず取扱説明書をよく読んでください。  
 本機は、ニッケル水素バッテリー（JWB2）の専用充電器です。  
 JWB-2以外のバッテリーの充電や充電以外の行為に使用しないでください。

JET ODO  
 Energy Verified Rendement Énergétique Vérifié  
 CE  
 RoHS  
 株式会社 ヤマハ電機 (中国) 有限会社  
 株式会社 Yamaha Motor Co., Ltd.  
 A/S 4E4: XXXX-XXXX

YAMAHA MOTOR CO., LTD.  
 MADE IN CHINA/FABRIQUE EN CHINE  
 株式会社 ヤマハ電機  
 2016-11 1611500001

## 2. Names of

### 2.1. iXpress 24"

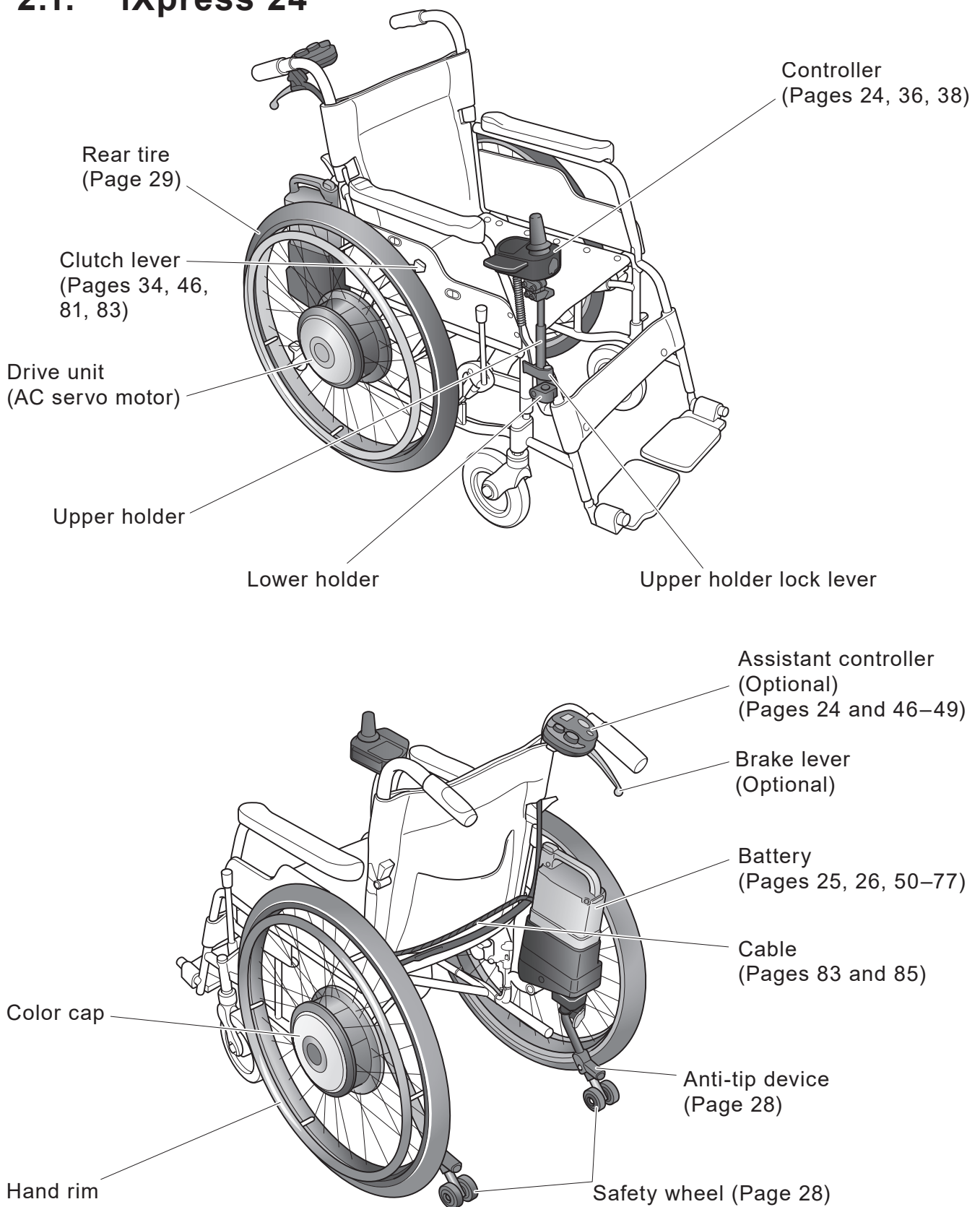

Either a nickel hydride battery set or a lithium ion battery set is supplied.

## 2.2. iXpress 16"

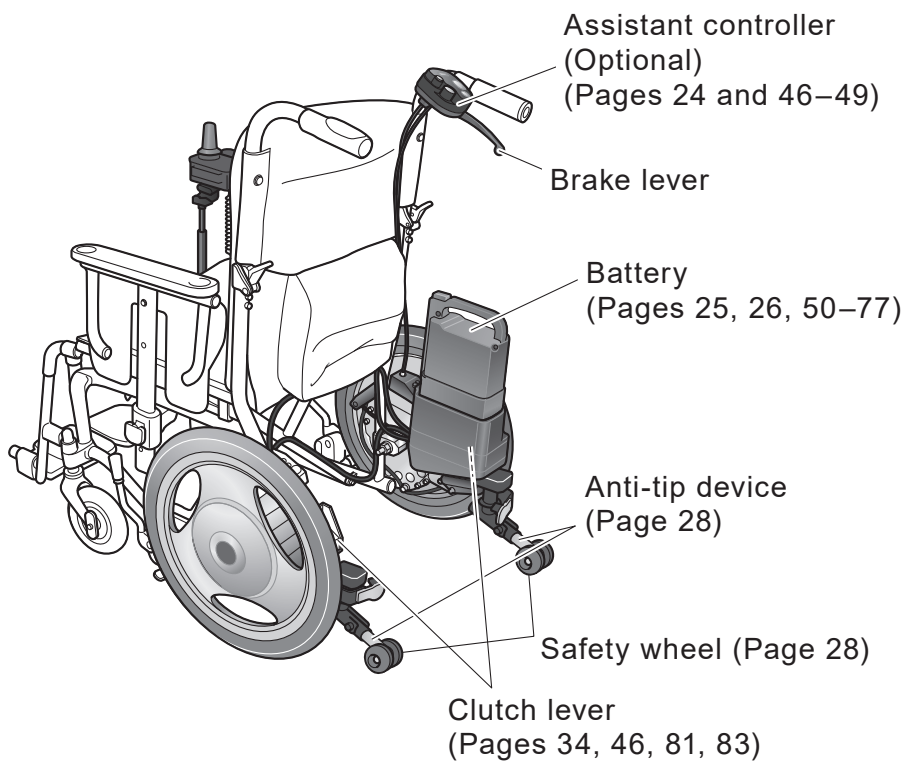
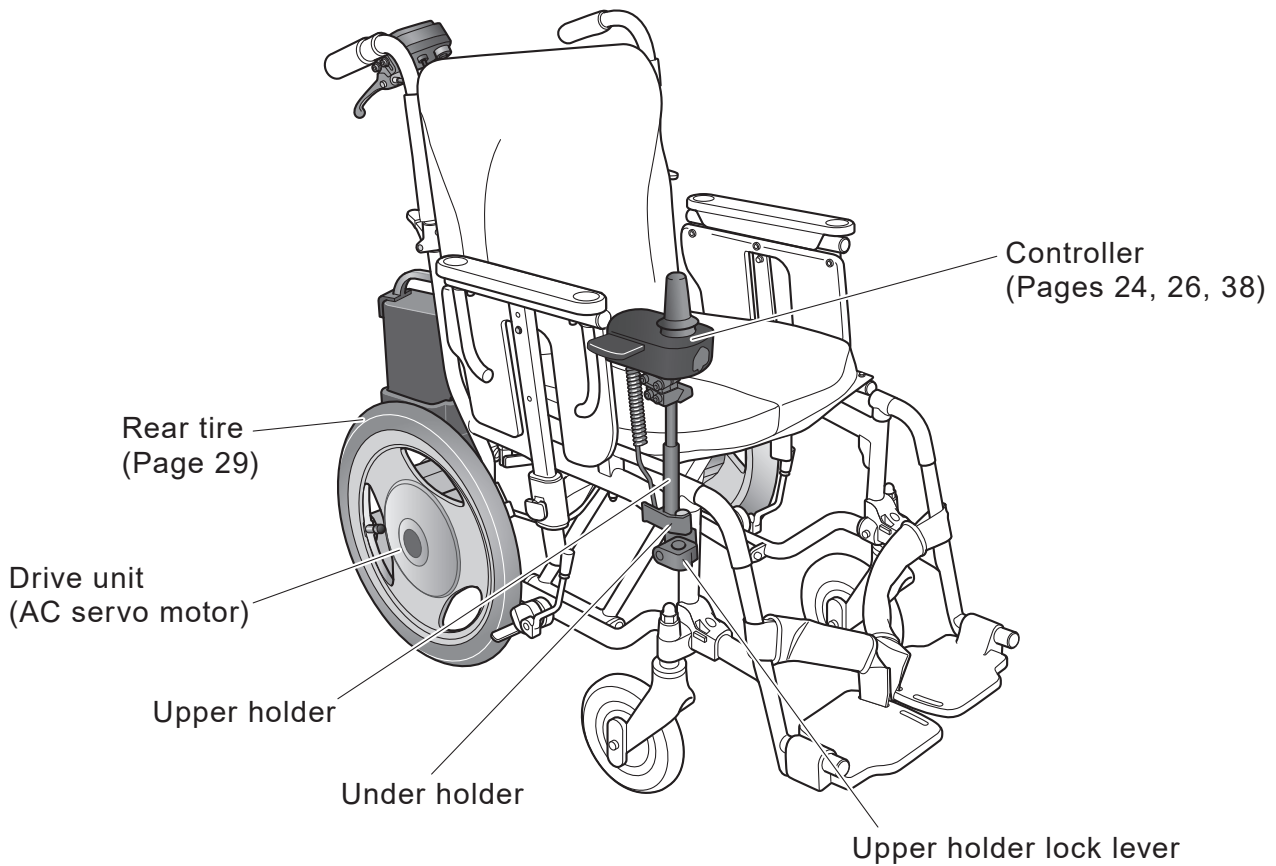

Either a nickel hydride battery set or a lithium ion battery set is supplied.

## 2.3. Controller

(Pages 30, 36–41)

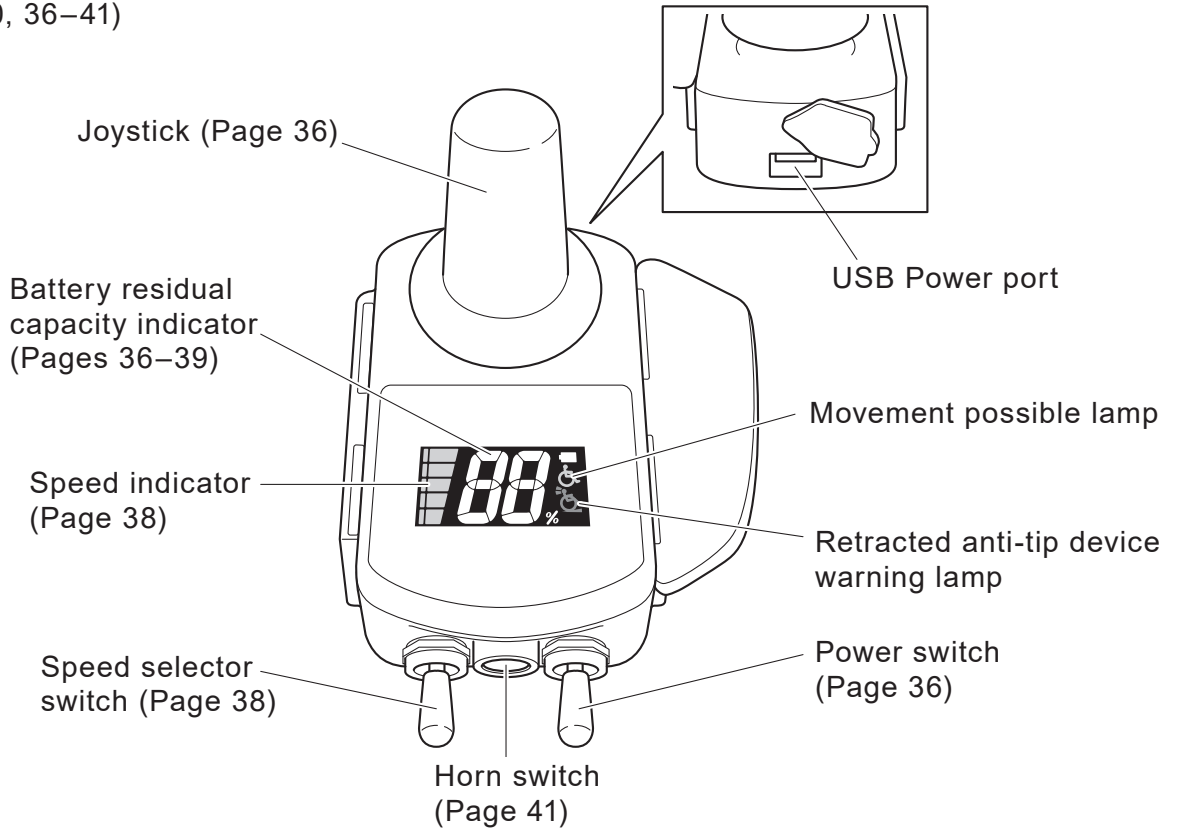

### NOTICE

- The USB power port is used only to supply power. It does not feature any communication functions.
- The capacity of the USB power port is 500 mA. It is not capable of charging / using a USB device that requires a power current greater than 500 mA.
- Do not insert any object other than a USB connector into the USB power port. Otherwise, the USB power port may be damaged.
- When not using the USB power port, be sure to install its rubber cap.

## 2.4. Assistant Controller (Optional)

(Pages 46–49)

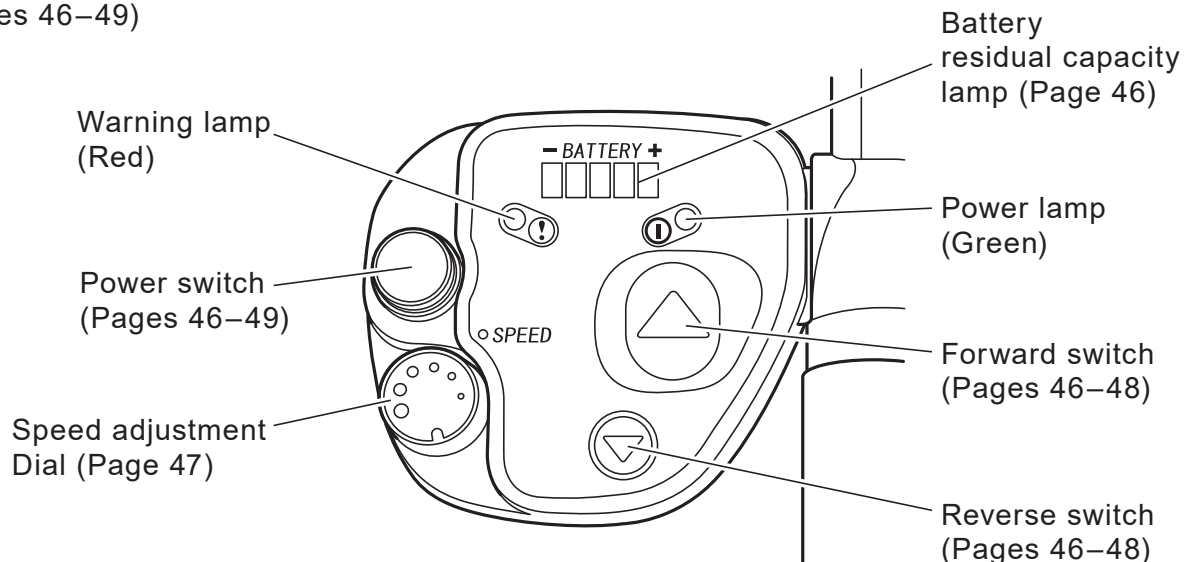

## 2.5. Nickel Metal Hydride Battery (JWB2)

Indicator switch  
(Pages 32, 55, 58, 61)

Grip (Handle)

Release button (Yellow)  
(Page 45)

Capacity indicator lamp  
(Pages 32, 55, 58, 61)

Battery fuse (Yellow 20 A)

Contacts  
(Page 32)

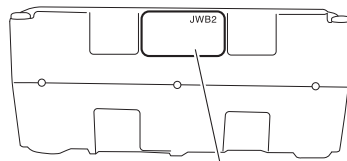

A code indicating the model (JWB2)  
and the manufactured lot is printed.

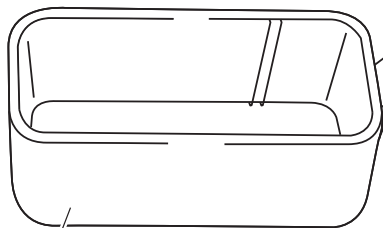

Spare battery fuse  
(Yellow 20 A)

Protective cap

### NOTICE

- If the battery fuse blows, instead of replacing it by yourself, consult with your dealer. If you replace the fuse without eliminating what caused it to blow, the fuse may blow again, or the main unit may malfunction.

## 2.6. Lithium Ion Battery (ESB1)

2

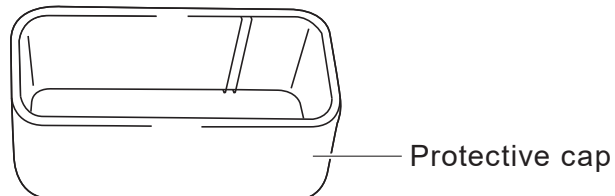
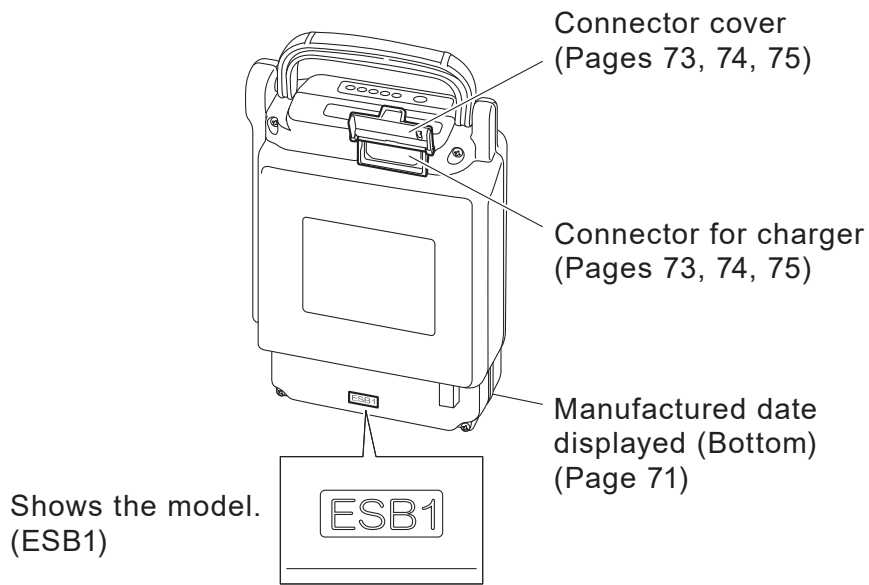
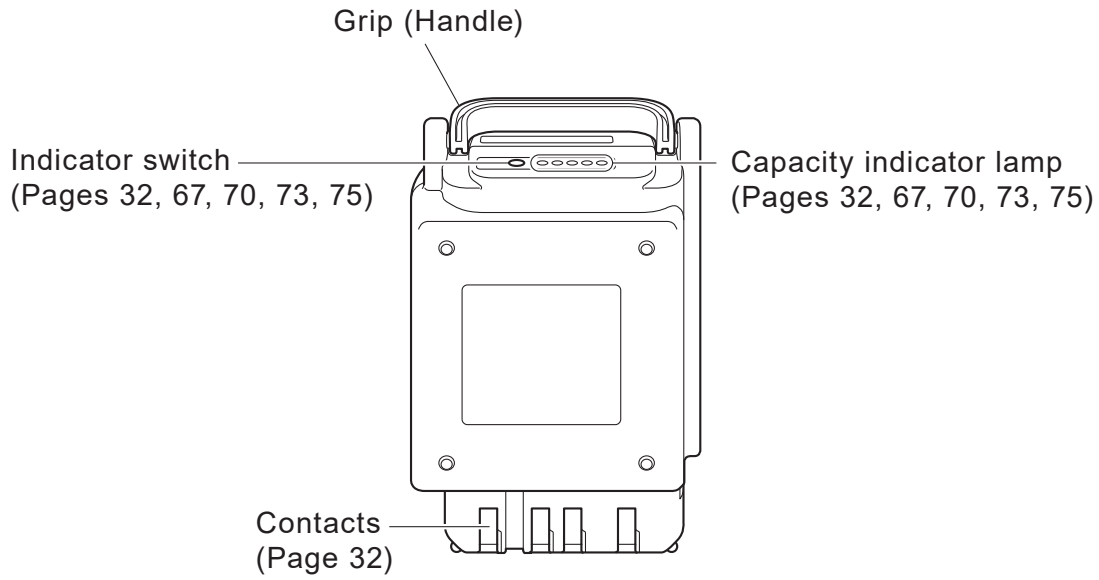



## 2.7. Charger for Lithium Ion and Nickel Metal Hydride Battery (ESC3)

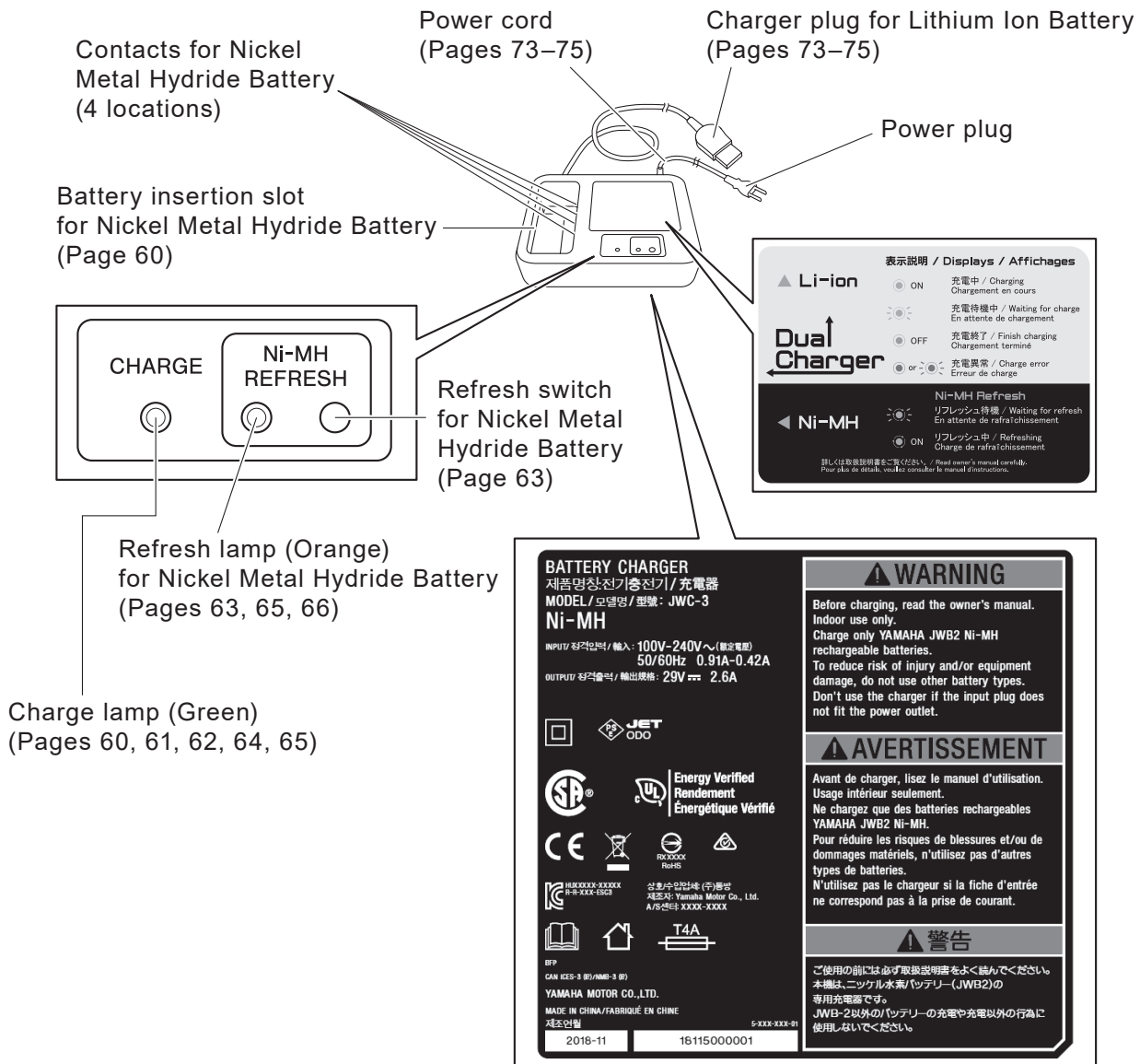

The label on the reverse side shows the model.

## 3. Before Sitting in the Wheelchair

### 3.1. Inspecting the Wheelchair

Inspect the wheelchair. If you detect any problem, contact your dealership.

#### (1) Anti-tip device

Check the anti-tip device to ensure that it is not deformed or greatly damaged.

Check the safety wheels of the anti-tip device to ensure that they are in the correct position for operation.

For details, refer to the wheelchair frame manual.

3

- Move the anti-tip device as shown in the figure to ensure that it is locked in position.

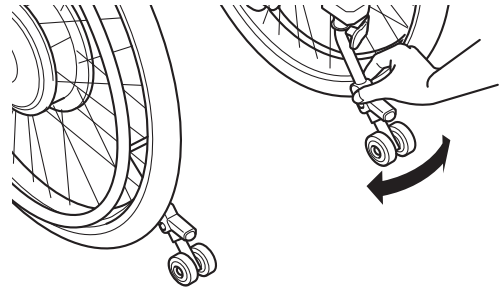

- If the anti-tip device is not locked in position, perform the following actions as shown in the figure until you hear a click confirming that the lock is engaged.

(a) Extract the anti-tip device.

(b) Move the anti-tip device back and forth to ensure that it is locked in position.

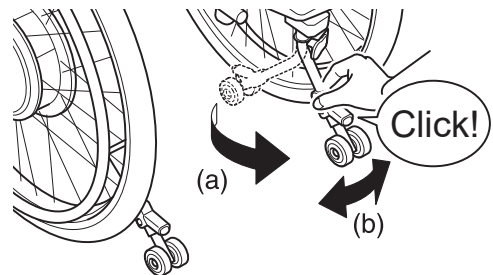



## WARNING

- The wheelchair may tip over if operated when the anti-tip device is removed or the safety wheels are not in the correct position. Do not operate the wheelchair when the safety wheels are not in the correct position. Only have the safety wheels folded or facing upwards when going over bumps with the assistant operations and other such situations.
- Continuing to use the wheelchair with a problem in the wheelchair body or the wheels may cause sudden damage to the wheelchair while traveling, and may result in a rollover or fall.

### (2) Rear tire

Check to ensure that there is tire depth.

Check the surface of the tire to ensure that there are no cracks in it.

Check to ensure that there is air in the tire. (Check by pressing the tire with your finger.)

If not enough, pump up to 450 kPa for iXpress 24" or 345 kPa for iXpress 16".

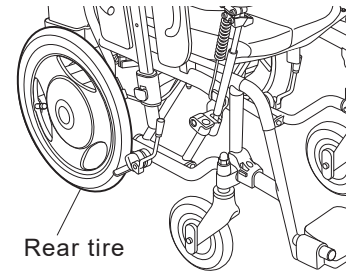
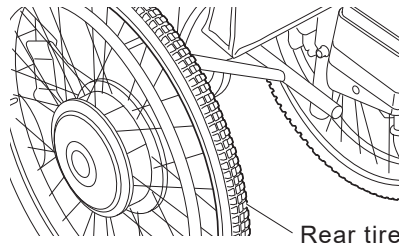

### (3) Parking brakes

Check to make sure that the parking brakes are applied.

Push the wheelchair with the brakes applied on both wheels to ensure that the tires do not move.

Check the parking brakes to ensure that they do not wobble.

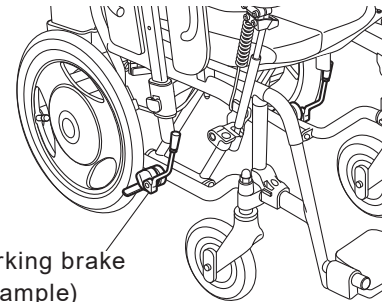
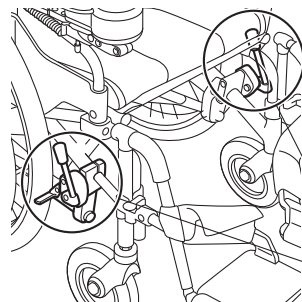

#### (4) Wheels

Check the wheels to ensure that they are not deformed or damaged.

Check the area where the wheel meets the frame to ensure that it does not wobble.

Check the spokes to ensure that they are not broken.

In case of the detachable units, make sure that the axle stopper balls are visible and that the axle shafts are securely locked so that the units will not come off.

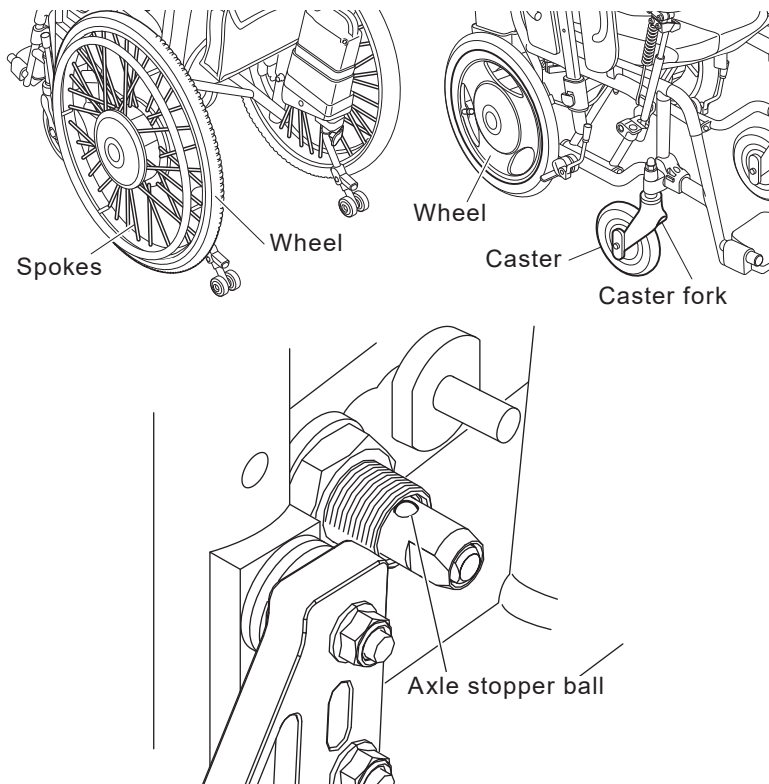

#### WARNING

- If the wheels are not installed properly, they might come off during riding. Before using the wheelchair, make sure that the wheels do not come off.

#### (5) Casters

Check to ensure that there is tire depth.

Check the tires to ensure that they are not damaged.

Check the caster forks to ensure that there are no cracks in them.

Check the nuts to ensure that they are not loose.



#### WARNING

- If the air pressure in the rear tires decreases, the parking brakes may become ineffective. Always keep the air pressure in the rear tires at the correct level.
- Continuing to use the wheelchair with a problem in the wheelchair body or the wheels may cause sudden damage to the wheelchair while traveling, and may result in a rollover or fall.
- If you find any unusual condition on the wheelchair in these inspections, contact your dealership.

#### (6) Controller

Check the controller to ensure that it is firmly secured to the wheelchair. (Try shaking and rocking the controller.)

Check the joystick to ensure that it is in an easy-to-operate position.

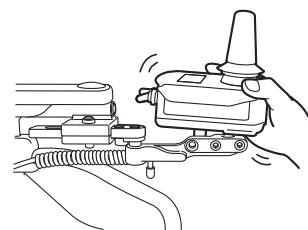

(7) Assistant controller (optional)

Check the assistant controller to ensure that it is firmly secured to the wheelchair. (Try shaking and rocking the assistant controller.)

Check the switches to ensure that it is in an easy-to-operate position.

Assistant controller

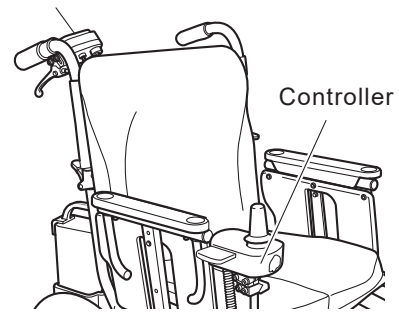

(8) Battery bag (optional)

Make sure that the left and right cable connectors are securely connected.

Make sure that the entire surfaces of the fasteners on the upper straps and lower fixing belt are adhered completely and securely.

Make sure that the upper straps and lower fixing belt are not loose, and do not have any slack.

(9) Foot supports

Make sure that the clearance between the foot supports and the ground is 5 cm or more.

Adjust the height of the foot supports to make 5 cm or more clearance.

 **WARNING**

- **Set the height of the foot supports so that the clearance between the foot supports and the ground is 5 cm or more. If the foot supports are too low, the foot supports may come in contact with bumpy ground or objects on the ground, possibly causing the wheelchair to tip over.**

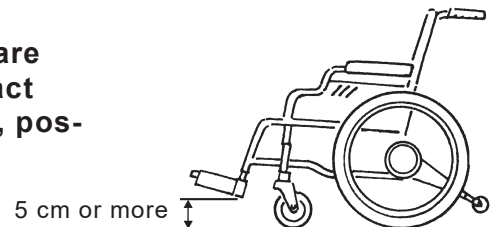

## 3.2. Checking Your Clothing

Wear bright-colored, easily visible clothing when operating the wheelchair. Do not operate the wheelchair while wearing clothing that is not suitable for wheelchair use. Refer to “1.5.5. General Operation” (Page 7).

 **WARNING**

- **Do not travel with clothing that are not safe for wheelchairs. If you drive the wheelchair with such clothing, you or other people in your surrounding may become injured.**

### 3.3. Checking the Residual Capacity of the Battery and Installing the Battery on the Wheelchair

- (1) Press the indicator switch to check the residual capacity of the battery. The residual capacity of the battery will be displayed on the capacity indicator lamps.

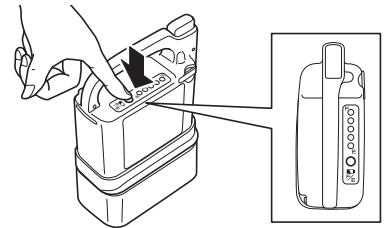

- (2) Check the contacts to ensure that they are not dirty or rusted. If the contacts are dirty or severely rusted, the wheelchair may be rendered immobile.

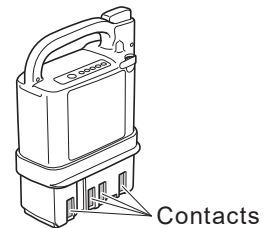

- (3) Install the battery on the wheelchair.

#### <How to install a nickel metal hydride (Ni-MH) battery>

Turn off the power switch

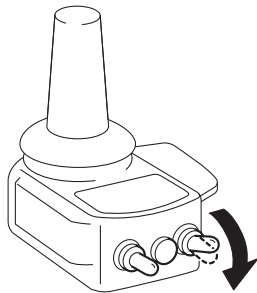

Insert the battery until it clicks into place.

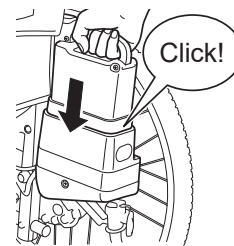

#### <How to install a lithium ion (Li-ion 22) battery>

Turn off the power switch.

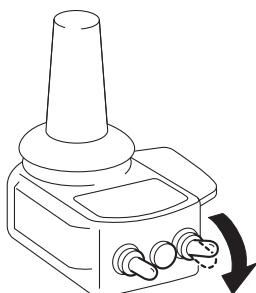

Insert the battery.

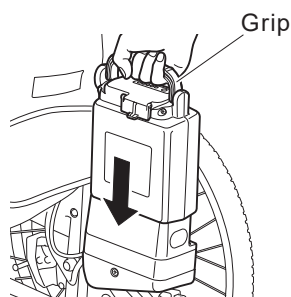

① Pull the grip down to the side.

② Firmly insert the battery.

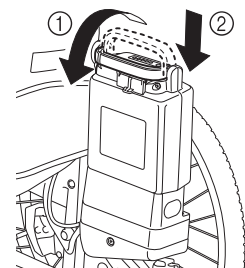

#### **! WARNING**

- Do not drop or apply an impact to the battery. This may cause the battery to become damaged, overheat, or rupture.
- Do not insert the battery if the battery slot is dirty or wet. This may cause a short circuit and lead to a fire or battery rupture.



## **WARNING**

- **When handling the lithium ion battery, ensure that you do not pinch your finger with the grip. Doing so may injure your finger.**

## ***NOTICE***

- **Do not replace the battery when the power is turned on. Doing so may damage the battery terminals and cause a malfunction.**

# 4. Riding the Wheelchair

## 4.1. Sitting in the Wheelchair

- (1) Place the wheelchair in a level and stable location and turn off the power switch (yellow).
- (2) Put the clutch levers of the left and right power units in the power drive position.
  - ① Power drive.... Traveling in power drive is possible. The brakes are applied when not traveling. Normally, use the wheelchair in this state.
  - ② Manual ..... The brakes are released and the assistant can push the wheelchair by hand.
- (3) Apply the parking brakes. If the wheelchair has no parking brakes, the assistant must hold it firmly.
- (4) Get into the wheelchair and firmly sit down so that you will not fall out.

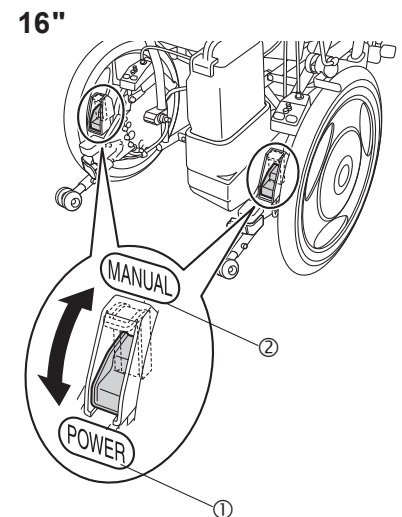
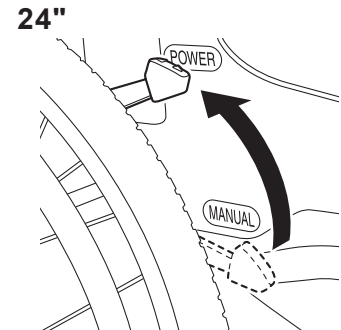





## WARNING

- **Get into the wheelchair in a level and stable location. If you park the wheelchair on an incline and try to get into it from there, you may lose your balance and fall out.**
- **When operating the iXpress 16", have the assistant shift the left and right clutch levers. Even if there is no assistant, the individual in the wheelchair should still not shift the clutch levers.**
- **If you get into the wheelchair when the left and right clutch levers are in the manual position and the parking brakes are released, the wheelchair may move unexpectedly, causing you to fall out and injure yourself. When getting into the wheelchair, make sure that the left and right clutch levers are in the power drive position and the parking brakes are applied.**
- **When switching the clutch levers to the manual position, apply the parking brakes in a level and stable location and have the assistant do so when the power is turned off.**
- **If you are using a wheelchair with no parking brakes, have the assistant hold the wheelchair to ensure that it doesn't move when you are getting into it. If you are getting into a wheelchair with no parking brakes when alone, the wheelchair may move unexpectedly, causing you to injure yourself or those around you.**
- **Do not ride the wheelchair while a USB device is connected to the USB power port. Otherwise, the controller might be damaged if the wheelchair bumps into an object. Also, a cable connected to the USB device might become coiled around the joystick, the clutch lever, or a rear tire, possibly causing an accident.**

## 4.2. Moving the Wheelchair

- (1) Turn on the power switch (yellow).

When the power to the wheelchair is turned on, all the lamps on the controller illuminate. Then, after 1 second, the “retracted anti-tip device” warning lamp turns off, and the battery residual capacity indicator indicates the battery level.

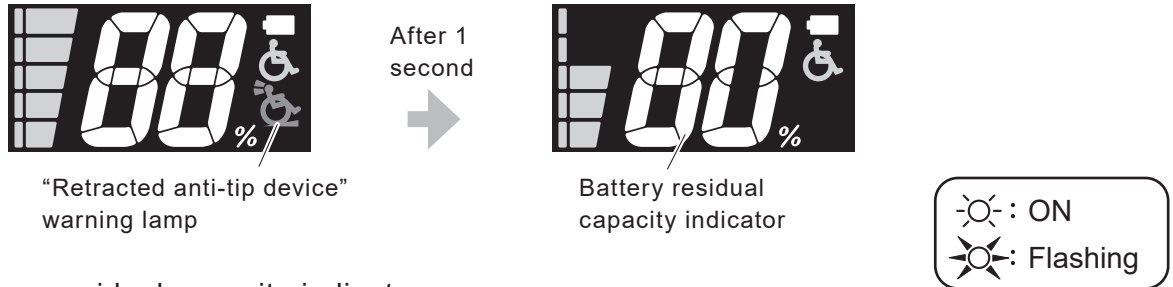

Battery residual capacity indicator

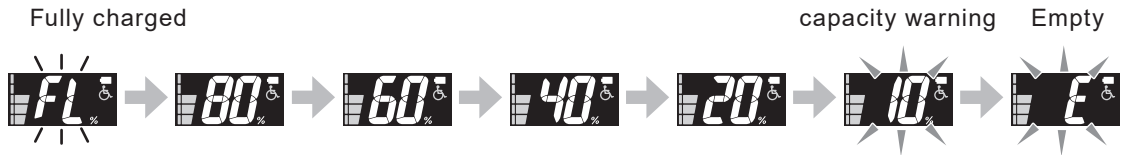

Battery residual capacity warning:

When the battery residual capacity becomes less than 10%, the residual capacity lamp flashes, and a short buzzer beeps “Pi Pi Pi Pi” (4 times).

4

- (2) If necessary, adjust the maximum speed.

For the adjustment method, refer to 4.3. Adjusting and Confirming the Maximum Speed.

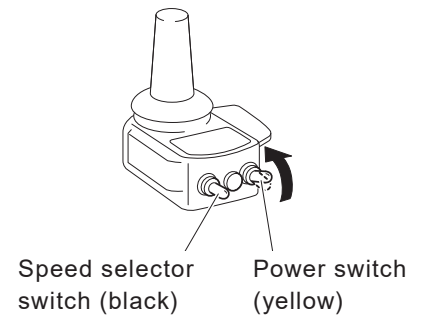

- (3) Release the parking brakes.

- (4) The wheelchair starts moving with you tilt the joystick to the desired direction.

Make sure that the joystick returns to its neutral position and the wheelchair stops properly when you release the joystick.

For beginners, refer to pages 47 and 48, and practice the basic operations until you become familiar with them.

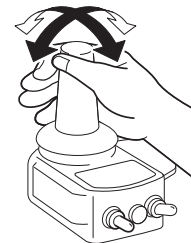

**TIP** If the power does not turn on

Is the power for the assistant controller turned on?

If the power for the assistant controller is turned on, the power for the controller will not turn on.

In this case, turn off the power switches on both controllers, and turn on the power for the controller.

**TIP** If the buzzer sounds and the wheelchair does not move

(a) Was the power turned on with the joystick tilted?

When you turn on the power switch with the joystick tilted, a safety device is engaged to prevent the wheelchair from moving.

In this case, a buzzer beeps (a long “Pi—” sound) and the power lamp (green) flashes.

Release the joystick, turn off the power, and then turn it back on again.

(b) Are you tilting the joystick with the left and right clutches in the manual position?

This is a buzzer to warn you that the clutch has been disengaged. (Beeps “Pi Pi, Pi Pi, Pi Pi”)

Turn off the power, switch the left and right clutches to the power drive position, and then turn the power back on.

**TIP** If the buzzer beeps while traveling

While traveling, if the load on the motor is too great, a buzzer (long Pi—, Pi—) sounds continuously.

(a) Is the live load too great?

The maximum load is 125 kg for iXpress 24" and 100 kg for iXpress 16". Do not exceed the maximum load.

(b) Are you trying to go up a steep slope?

The practical climbing angle is 6 degrees. Choose a travel route that does not exceed 6 degrees.

## 4.3. Adjusting and Confirming the Maximum Speed

With the speed selector switch, you can adjust and confirm the maximum speed. Move the switch up to increase the speed, and down to decrease it. Perform the following steps to adjust the maximum speed.

- (1) Move the speed selector switch to change the speed.

Hold the switch up to move the lamp up continuously towards high-speed.

To decrease the maximum speed, perform the same steps in reverse direction.

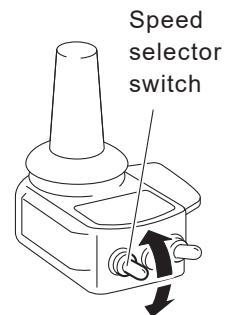

Speed is adjustable in five steps

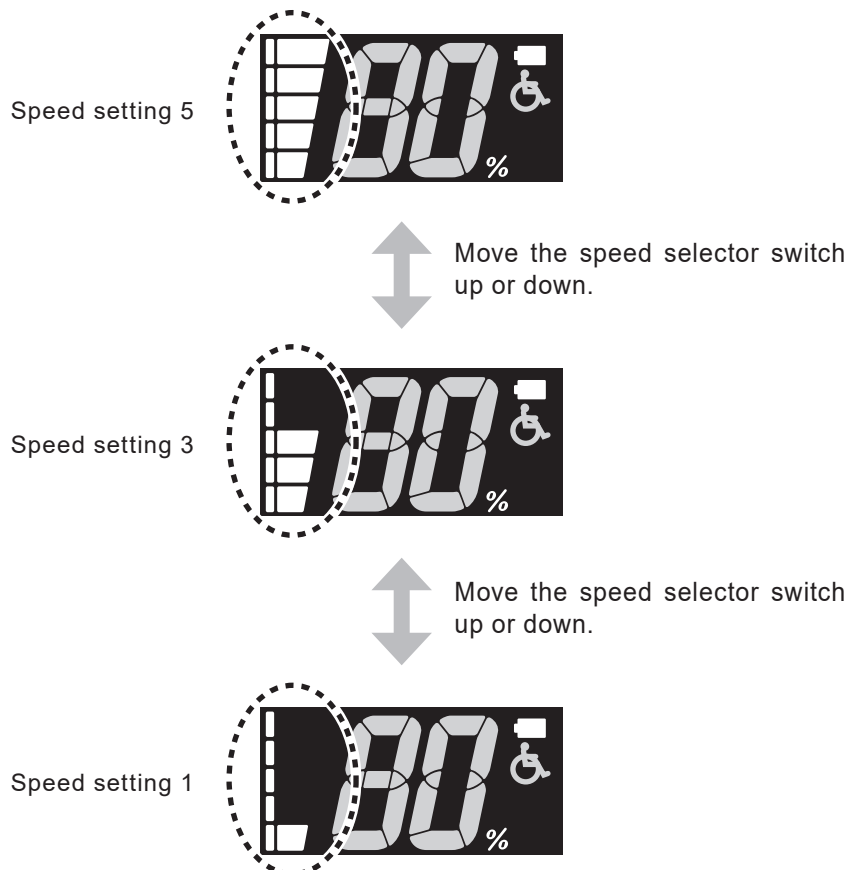

## 4.4. Checking the Residual Capacity of the Battery during Operation

You can always check the residual capacity of the battery with the LCD of the controller.



Battery residual capacity indication

### (1) Battery residual capacity indication

The battery residual capacity indication varies according to the battery type. For the nickel metal hydride battery and lithium ion battery (gray case), the battery residual capacity is indicated in increments of 20%. For the lithium ion battery (black case), the battery residual capacity is indicated in increments of 10% from 80% to 50% and in increments of 5% from 50%.

Nickel metal hydride battery and lithium ion battery (gray case)



Lithium ion battery (black case)



### (2) Battery residual capacity warning

When the battery residual capacity becomes less than 10%, the residual capacity indication flashes, and a short buzzer beeps “Pi Pi Pi Pi” 4 times.

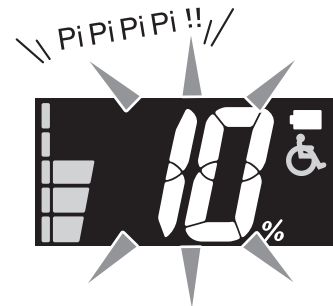

### (3) Once the battery runs out, the residual capacity indication changes to “E” and flashes, a long buzzer beeps “Pi—” once and stops.



### ! WARNING

- When the buzzer beeps to indicate the battery residual capacity warning, promptly move to a safe place, turn off power and charge the battery, or replace with a spare battery (sold separately). It is dangerous when you get into a situation where you cannot move, such as when crossing a road.

## 4.5. Anti Theft Function

### How to Set the Anti Theft Function

- (1) Turn on the power switch.
- (2) Set the speed level 1 with the speed selector switch.

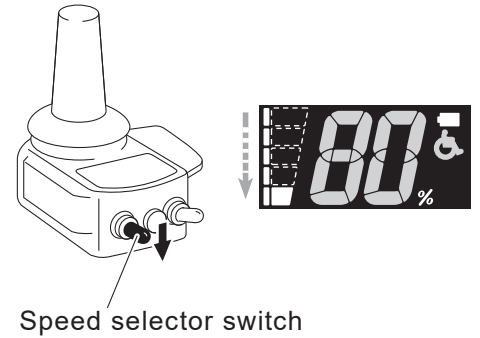

- (3) After releasing the switch once, hold the speed selector switch down and you will hear the beep sound.

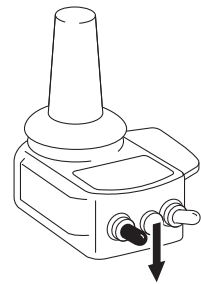

- (4) Press and hold the horn switch soon after the beep sound.

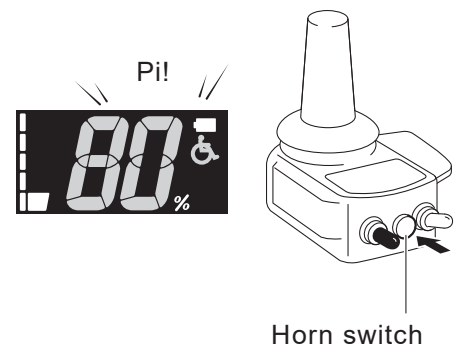

**TIP** If you hear the horn sound when you hold the horn switch, try again from (3).

- (5) Completed this setting after "Pi" sound again.

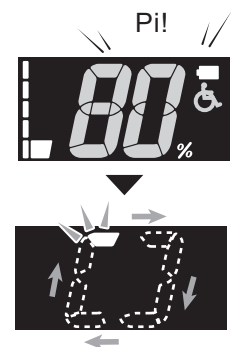

**TIP** Anti theft function keeps on, turning the power switch off and then back on.

## How to Unlock the Anti Theft Function

- (1) Hold the speed selector switch up until the beep sound.

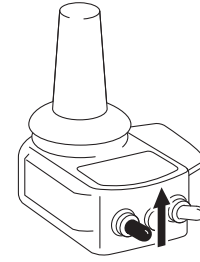

- (2) Press and hold the horn switch after the beep sound.

**TIP** If you can hear the horn sound when you hold the horn switch, try again.

- (3) Completed to unlock the anti theft function after “Pi” sound.

## 4.6. Other Functions

- (1) Using the horn

When you push the horn switch on the controller, the horn sounds.

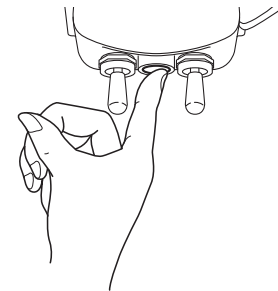

- (2) Auto power off function

With the power turned on, if the joystick is not operated for 10 minutes, the power turns off automatically (default setting).

To resume operation, turn the power switch off and then back on.

## 4.7. Practicing Basic Operations

- (1) Practice the basic operations on a safe, large, level ground.

### Basic Operations 1

- ① In the beginning, adjust the maximum speed to a slow speed and learn how to use the joystick.
- Tilt the joystick in the direction you want to go.
  - Move the joystick slowly.
- ② With the maximum speed set to a slow speed, learn the feel of joystick operation.
- To go slowly, tilt the joystick slightly.
  - To go fast, tilt the joystick further.
  - To stop, move the joystick back to original position.
  - When you return the joystick to the center position, and the wheelchair stops.

- ③ Try moving in the following manners.

■ **Forward and stop** ■ **Backwards**

- Familiarize yourself with the handling and performance characteristics of backward travel.
- Check behind you for safety.

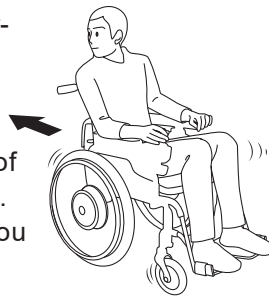

■ **Turns**

- Make turns on a single spot.
- Practice turning right and left.

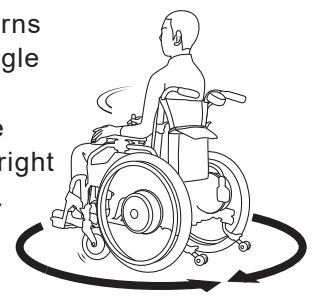

■ **S-shaped curves**

- Practice until you can travel in the desired direction.
- Learn the feel of speed and timing when making turns.

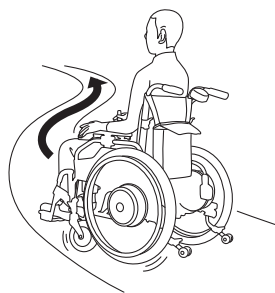

■ **Avoid obstructions**

- Practice avoiding obstructions.
- Stop before reaching the obstruction.

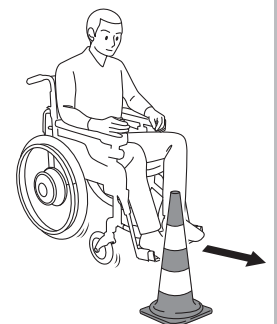

- ④ Adjust the maximum speed to medium and fast speeds, and practice in the same way.

### NOTICE

- If there is an assistant, use caution to prevent colliding into him or her when moving backward.



(2) Practice in an actual location where you intend to use the wheelchair.

### Basic Operations 2

#### ① Sidewalk

- Be careful not to bump into pedestrians and obstructions.
- Adjust your operation to suit the road surface conditions.

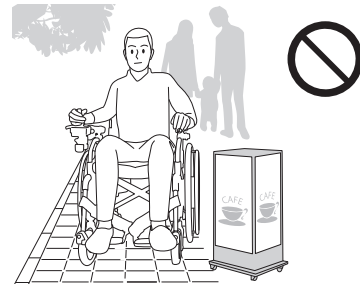

#### ② Up and down a level difference

- Learn how to safely maneuver up and down small curbs and know the limits.
- Stop your wheelchair before a curb, and then proceed carefully.

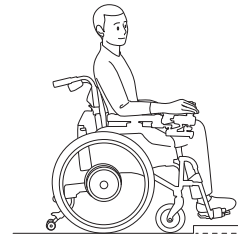

#### ③ Crosswalk

- Allow sufficient time to cross the road at a crosswalk.
- Be careful with the curb between the road and the sidewalk.

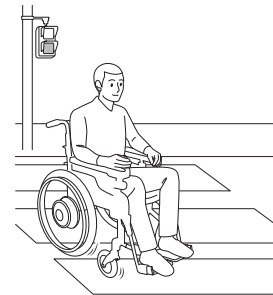

#### ④ Slope

- Get the feel of riding up and down a slope.
- Restart carefully on an uphill.

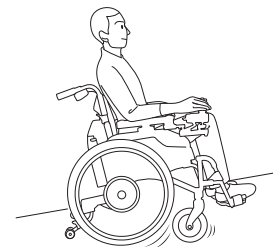

#### ⑤ Automatic door

- Practice at the proper stopping position.

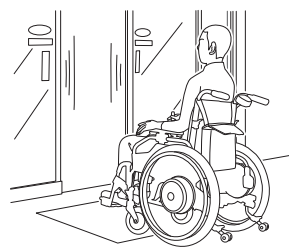

4

**TIP** Check the condition of the road you frequently use on wheelchair on a daily basis.

Is there a large level difference, steep slope, or rough road?

Try to travel on a route that does not pass through such dangerous locations.

## 5. After You are Finished Riding the Wheelchair

### 5.1. Getting Out of the Wheelchair



#### WARNING

- After you are done traveling in power driver mode, be sure to turn the power off. If the power is on when you get off the wheelchair, your body may hit against the joystick, causing it to start moving, and you or other people in your surrounding may get injured.
- Get off the wheelchair in a level and stable location. If you park the wheelchair on an incline and try to get off it from there onto a bed or a chair, you may lose your balance and fall off the wheelchair.
- If you get off the wheelchair with the left and right clutch levers in the manual position and the parking brakes released, the wheelchair may move unexpectedly, causing you to fall off and injure yourself. When getting off the wheelchair, make sure that the left and right clutch levers are in the power drive position and the parking brakes are applied.

(1) Park the wheelchair on a flat location.

(2) Turn off the power switch.

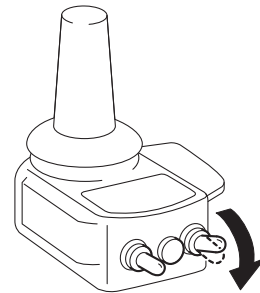

5

(3) Apply the parking brakes.

(The left and right clutch levers should be in the power drive position.)

(4) Get off the wheelchair onto a bed, etc.

## 5.2. Removing the Battery

Disconnect the battery from the wheelchair.  
Store the battery with the protective cap on it.

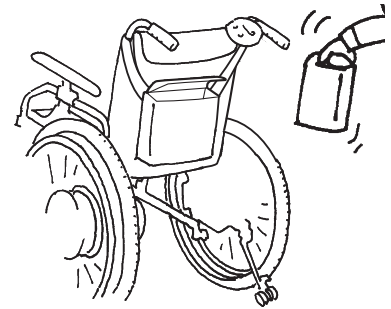

### <How to remove a nickel metal hydride (Ni-MH) battery>

Turn off the power switch.

Disconnect the battery by pulling it straight outwards while pressing the release button.

Store the battery with the protective cap on it.

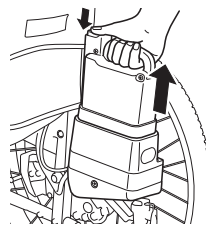
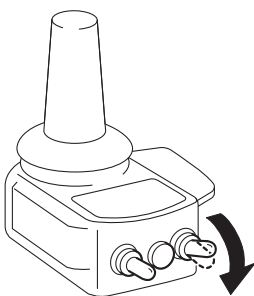

Protective cap

### <How to remove a lithium ion (Li-ion 22) battery>

Turn off the power switch.

- ① Stand the grip upright.
- ② Disconnect the battery by pulling it straight outwards. (Do not pull it out on an angle.)

Store the battery with the protective cap on it.

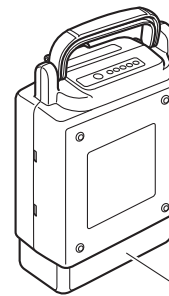
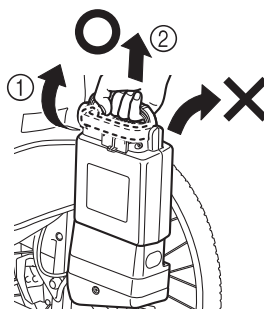
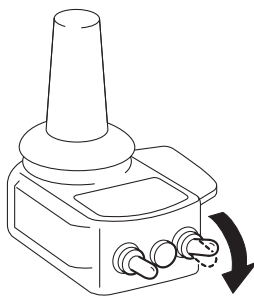

Protective cap

### WARNING

- Be sure to store the disconnected battery with the protective cap on it. Exposed contacts can cause short circuits and lead to a fire or battery rupture.

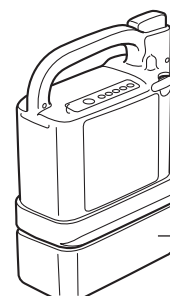

Protective cap

# 6. How to Use the Assistant Controller

Even if you are using the wheelchair with assistive operation, read “3. Before Sitting in the Wheelchair”, “4. Riding the Wheelchair”, “5. After You are Finished Riding the Wheelchair”.

## 6.1. Getting in the Wheelchair

Have the user get in the wheelchair according to “4.1. Sitting in the Wheelchair”.

## 6.2. Starting Assistant Travel Mode

- (1) Switch the left and right clutches to the power drive position.

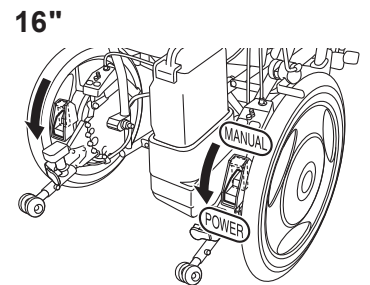
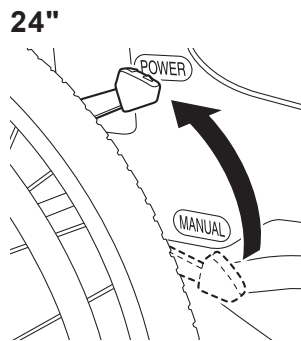

- (2) Turn on the power for the assistant controller.

When you turn on the power, the lamp display changes as shown in the lower-right figure.

When you turn on the power switch, if the battery residual capacity is less than 10%, the warning lamp flashes, and a buzzer beeps “Pi Pi Pi Pi” (4 times). Charge the battery at your earliest convenience.

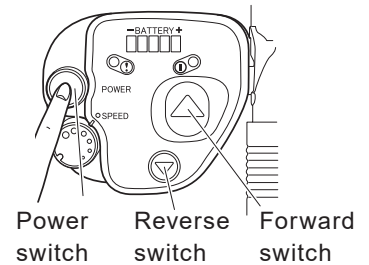

The battery residual capacity lamp indicates the current battery residual capacity.

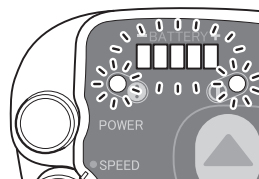

All lamps turn on.

After 1 second

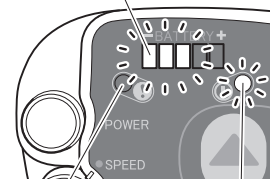

The warning lamp (red) turns off.

The power lamp (green) stays lit.

- (3) Adjust the speed as necessary.

Turn the speed adjustment dial clockwise to increase speed, and counterclockwise to decrease speed.

In the beginning, adjust it to a low speed. Gradually adjust the speed after you become accustomed to the operation.

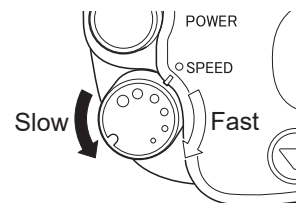

The speed can be adjusted steplessly within the range of 1.1 to 4.9 km/h forward and 0.4 to 1.9 km/h backward.

- (4) Release the parking brakes.  
 (5) Push the Forward (or Reverse) switch to start moving.

Releasing the Forward (or Reverse) switch stops the wheelchair.

Securely grip the handgrips.

To change the direction of motion or to turn around, operate using the “handgrips”.

To change the position and angle of the assistant controller, refer to page 46.

### Basic Operations

#### ■ To change the direction of movement or to turn.

- Operate with the handgrips.

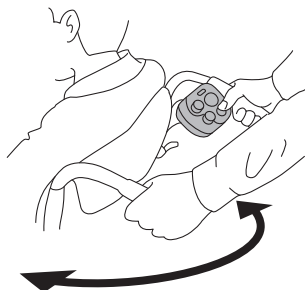

#### ■ To descend a slope

- Descend in reverse to avoid the risk of plunging forward.

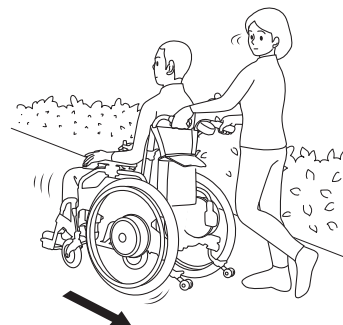

Perform the following operations after turning off the power and switching the clutches to the manual position.

#### ■ Getting up a curb

- Move the wheelchair close to a curb at a right angle, and then, while gently stepping on the tipping plate on the anti-tip device as if pushing it forward, pull the “handgrips” down and rearward to raise the casters.

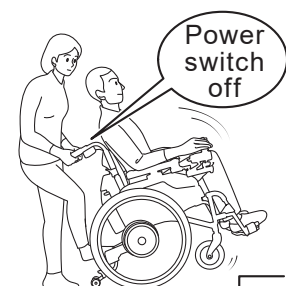

#### ■ Getting up a high curb

- Turn off the power switch, and stow the anti-tip device to get up a high curb. After getting up the curb, be sure to lower the safety wheels on the anti-tip device.

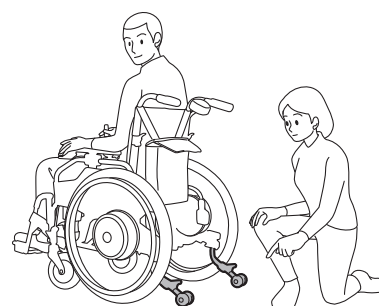

**TIP** If the power does not turn on

Is the power for the controller turned on?

If the power for the controller is turned on, the power for the assistant controller will not turn on.

In this case, turn off the power switches on both controllers, and turn on the power for the assistant controller.

**TIP** The battery residual capacity lamp does not turn on

If the warning lamp is lit or flashing, it means that the battery has run out.

If the warning lamp turns on immediately after replacing the battery with a fully charged battery, and the wheelchair does not move, there may be a malfunction in the unit.

Contact your dealer.

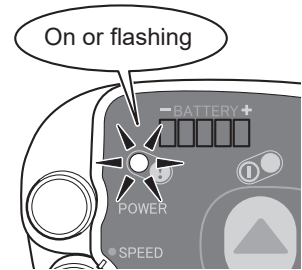

**TIP** If the buzzer sounds and the wheelchair does not move

Are you pushing the operation button with one or both of the left and right clutch levers in the manual position?

This is a buzzer to warn you that the clutch has been disengaged. (Beeps "Pi Pi, Pi Pi, Pi Pi")

Turn the power off, switch both of the left and right clutch levers to power drive position, and turn the power back on.

## 6.3. After Assistant Operations are Finished

- (1) Park the wheelchair on a flat location.
- (2) Turn off the power switch.
- (3) Apply the parking brakes.
- (4) Set the left and right clutch levers in the power drive position.
- (5) Have the user get off the wheelchair.
- (6) Disconnect the battery from the wheelchair.  
Store the battery with the protective cap on it.

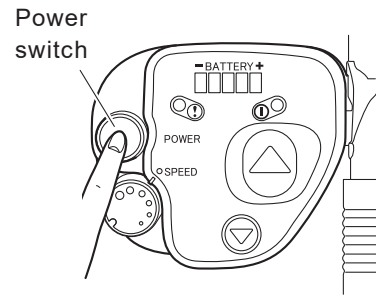

### WARNING

- After you are done traveling in assistant power driver mode, be sure to turn the power off. If the power is on when the user get off the wheelchair, the body may hit against the switches, causing it to start moving, and you or other people in your surrounding may get injured.
- Get off the wheelchair in a level and stable location. If you park the wheelchair on an incline and try to get off it from there onto a bed or a chair, the user may lose the balance and fall off the wheelchair.
- If the user get off the wheelchair with the left and right clutch levers in the manual position and with the parking brakes released, the wheelchair may move unexpectedly, causing the user to fall off and injure himself/herself. When getting off the wheelchair, make sure that the left and right clutch levers are in the power drive position and the parking brakes are applied.

### WARNING

- Be sure to store the disconnected battery with the protective cap on it. Exposed contacts can cause short circuits and lead to a fire or battery rupture.

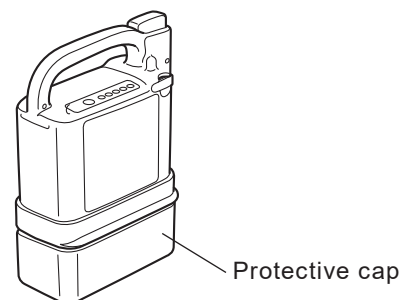

# 7. Handling the Batteries and Chargers

## 7.1. Types of Batteries

There are two types of batteries you can use for iXpress.

- Nickel metal hydride battery (JWB2)
- Lithium ion battery (ESB1)

Both types of batteries are sealed dry-cell batteries with a built-in microcomputer. Since the batteries differ in characteristics and charging method, first check the battery type you want to use.

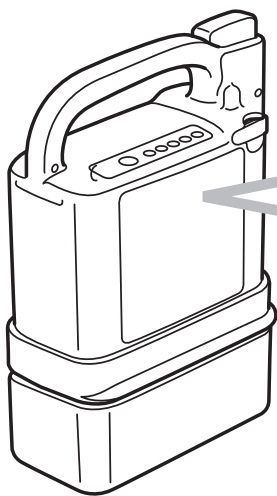

Check the label on the battery.

The label on the nickel metal hydride battery shows “Ni-MH”.

The label on the lithium ion battery shows “Li-ion 22”.

Read “8. Nickel Metal Hydride Battery and Charger” if you are using a nickel metal hydride battery, and “9. Lithium Ion Battery and Charger” if you are using a lithium ion battery.

TIP

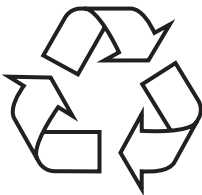

Recycling the battery

The battery for iXpress is a recyclable battery that contains valuable resources.

Contact the dealer to recycle your used batteries.

## 7.2. Maintenance

Always keep the contacts of the battery and charger clean. If the contacts are dirty, wipe them using a dry towel. Do not use a wet towel or touch the contacts directly. Otherwise, electric shock could result. If the exterior of the battery or charger is dirty, wipe it using a towel. If the dirt is excessive, use a tightly wrung-out towel.



## 7.3. Warnings and Notes for Battery Handling

### WARNING

- If you mishandle either of these batteries or their chargers, it may result in heat generation, rupture, electric shock, or injury. Be sure to adhere to the items below.

Do not recharge the battery using a charger other than the designated charger, or use the battery on anything other than the specified wheelchair.

Do not touch the metal terminals of the battery or charger directly with your fingers or clean the terminals with a wet towel. Otherwise, electric shock or a short circuit could result.

Do not disassemble or modify the battery.

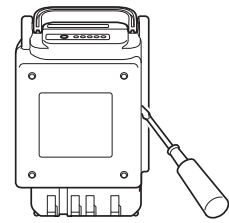
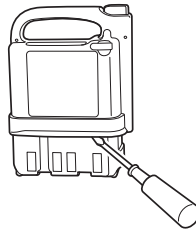

Do not place the battery near an open fire or throw it into a fire.

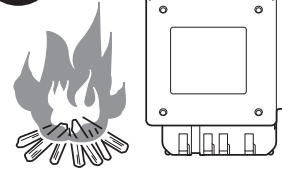

Do not place the battery in water, or splash water on it.

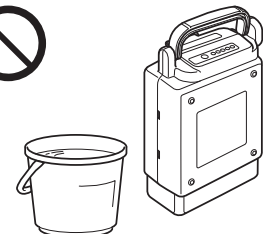

When transporting the wheelchair, in an automobile, for example, remove the battery from the wheelchair.

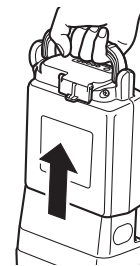
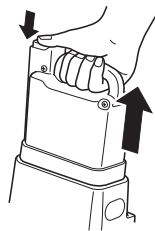

Do not short the terminals of the battery with wires or other metals. Always put on the protective cap when the battery is not in use.



Protective cap

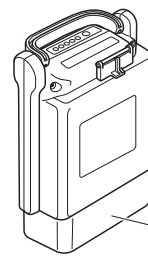

Protective cap



## WARNING

- If you mishandle either of these batteries or their chargers, it may result in heat generation, rupture, electric shock, or injury. Be sure to adhere to the items below.

Do not store the battery in a place where children or pets could come near it.

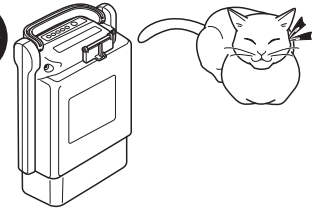
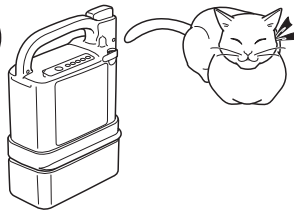

Do not drop or subject the battery to impact.

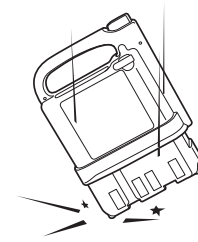

Do not use a broken or damaged battery.

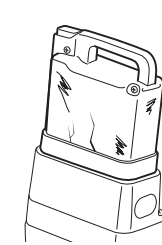

Do not charge the battery in a place where children or pets could come near it.

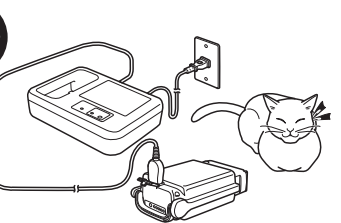
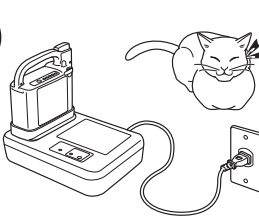

Use the charger on a level surface. After use, do not keep it plugged into the power outlet.

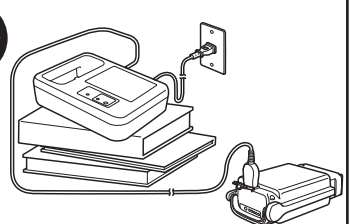
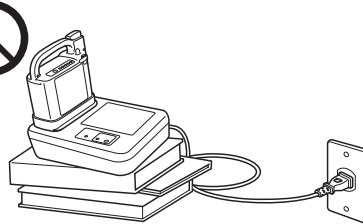

Do not use the charger outdoors or near any flammable object.

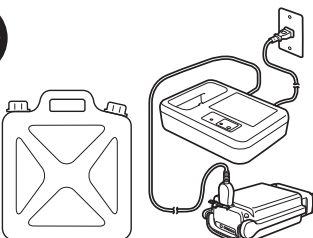
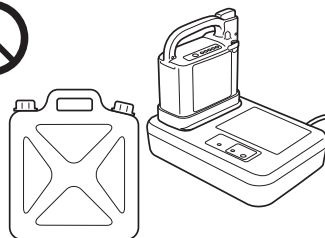

**⚠ WARNING**

- If you mishandle either of these batteries or their chargers, it may result in heat generation, rupture, electric shock, or injury. Be sure to adhere to the items below.

The charger can be used by children aged from 8 years and above and persons with reduced physical, sensory or mental capabilities or lack of experience and knowledge if they have been given supervision or instruction concerning use of the charger in a safe way and understand the hazards involved. Children shall not play with the charger. Cleaning and user maintenance shall not be made by children without supervision.

Do not use the charger, if the power plug does not fit the power outlet.

When using the extension cord with charging the battery, use it under the current capacity of the extension cord.

Do not use a damaged cord.

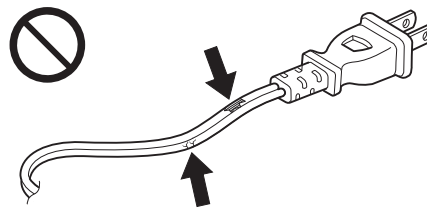

Do not touch the charger and power cord with a wet hand.  
Do not use the charger submerge it in water, splash water on it or leave it in the rain.

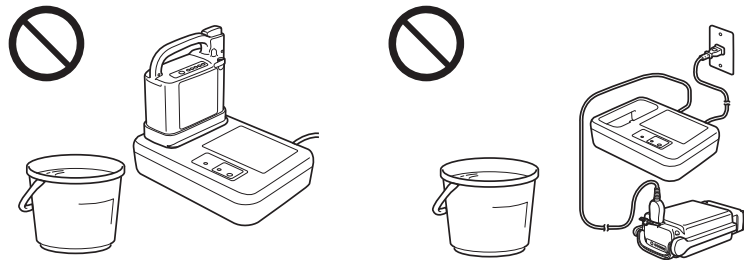

Do not disassemble or modify the charger.

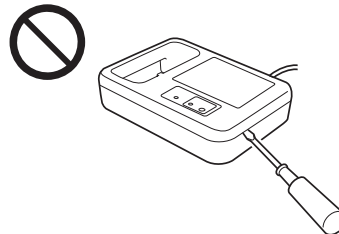

Do not drop or subject the battery to impact.

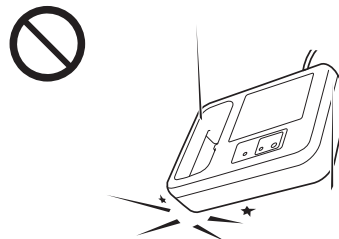

While charging, do not place anything around the charger.  
Make space for the heat radiation.

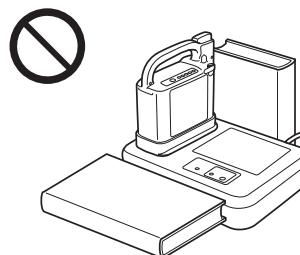



## WARNING

- If you mishandle either of these batteries or their chargers, it may result in heat generation, rupture, electric shock, or injury. Be sure to adhere to the items below.

Do not insert the cords or other items into the Nickel Metal Hydride battery socket.

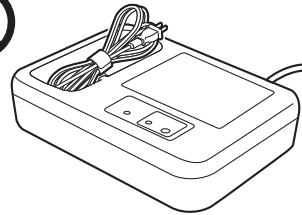

If the battery or the charger is deformed or has an unusual odor, or if you notice any other abnormality, do not use the battery or charger.

When inserting or removing the lithium ion battery, be careful not to pinch your finger with the grip.

Avoid prolonged contact with the skin.

It is normal for the charger to heat up while it is charging. Therefore, prolonged contact with the skin may result in a low-temperature burn injury.

# 8. Nickel Metal Hydride Battery and Charger

## 8.1. Features of the Nickel Metal Hydride Battery (JWB2)

- Equipped with Battery Management Control System (BMC). (built-in microprocessor) This is a system that uses a computer to track charge/discharge status, operating conditions, and temperature.
- An environmentally-friendly battery that does not contain mercury or cadmium.
- Compact but high capacity. (Capacity: 24 V × 6.7 Ah)

## 8.2. How to Use the Nickel Metal Hydride Battery (JWB2)

### (1) Attaching and removing the battery to and from the wheelchair

For instructions on attaching and removing the nickel metal hydride battery to and from the wheelchair, see “4. Riding the Wheelchair” and “5. After You are Finished Riding the Wheelchair”.

### (2) Checking the residual capacity of the battery

Press the indicator switch to display the battery’s residual capacity.

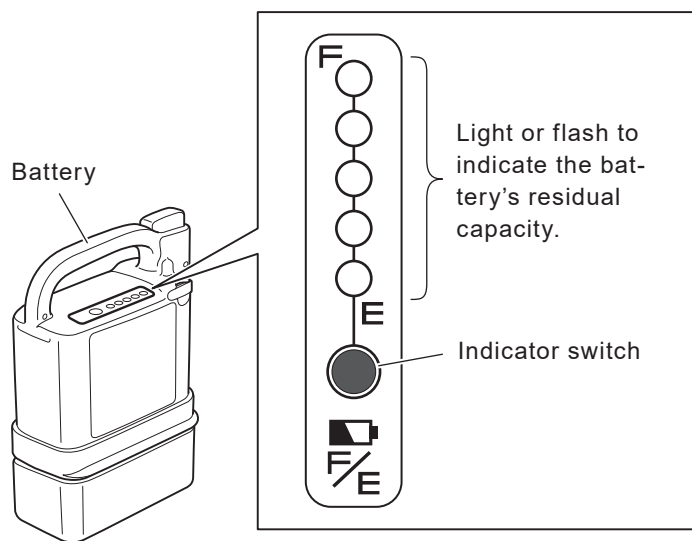

80 – 100%

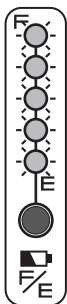

60 – 80%

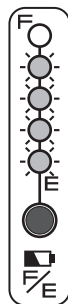

40 – 60%

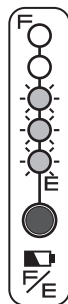

20 – 40%

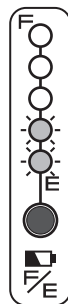

10 – 20%



0 – 10%



○ : Off

● : On

⊛ : Flashing

### (3) Storing the battery

Store batteries in a cool, dry area. (For the temperature, refer to “8.3. Characteristics and Handling of the Nickel Metal Hydride Battery (JWB2)”)

Fully charge the battery that you do not plan to use for a long period of time (30 days or more). If you intend to store the battery for more than 3 months without using it, fully charge the battery every 3 months.

Always put on the protective cap when storing the battery.

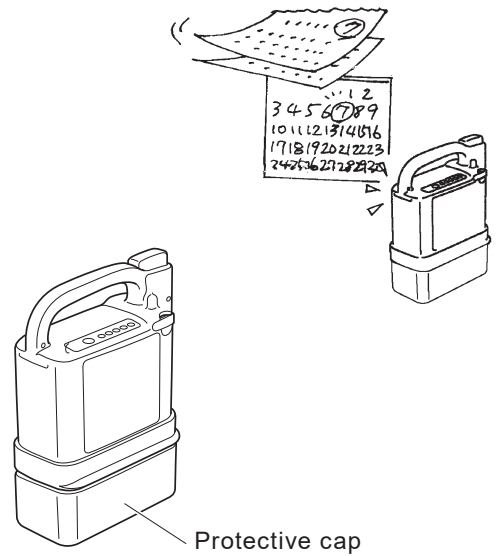

## 8.3. Characteristics and Handling of the Nickel Metal Hydride Battery (JWB2)

### (1) Ambient temperatures

#### <Recommended temperatures>

When in use on the wheelchair: Temperature range between 0 to 35 °C
When removed from wheelchair and stored: Temperature range between 10 to 25 °C
When charging: Temperature range between 10 to 25 °C

- Storing the battery in excessively high or low temperatures will speed up its degradation, and its capacity will rapidly decrease.
- Using the wheelchair in excessively low temperatures will cause the battery deterioration to speed up and its capacity to rapidly decrease. For information on degradation, see “Battery’s deterioration characteristics” on the next page.

#### <Available temperatures>

When in use on the wheelchair: Temperature range between -25 to 50 °C
When removed from wheelchair and stored: Temperature range between -40 to 65 °C
When charging: Temperature range between 0 to 40 °C

Depending on the ambient temperature, the distance that can be traveled becomes shortened and the battery deterioration will be accelerated.

In order to maximize the battery’s performance, it is recommended that you use the battery under the following conditions.

### (2) Memory effect and refresh charging

When a shallow discharging and charging cycle is performed repeatedly on a nickel metal hydride battery, a phenomenon called the memory effect occurs, in which the actual usable capacity decreases.

The memory effect can be prevented and eliminated by fully discharging the battery and then recharging (refresh charging).

If refresh charging is necessary, the microcomputer in the battery sends the information to the charger and the refresh lamp on the charger flashes. When recharging, if the refresh lamp on the charger flashes, press the refresh switch to perform a refresh charge cycle. Refresh charging takes longer than normal charging.

For details on refresh charging, refer to "8.5. Refresh Charging the Nickel Metal Hydride Battery (JWB2)".

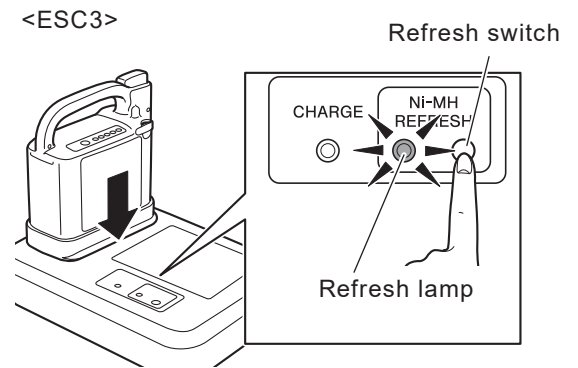

### (3) Battery's deterioration characteristics

All batteries are consumables. A battery gradually deteriorates and its capacity decreases over time and with use.

The extent to which the capacity decreases by deterioration depends on the use conditions.

**TIP** For a nickel metal hydride battery, its capacity will decrease to approximately 60% of that of a new battery after 300 charge/discharge cycles, under normal use.

Even if a battery is not used, when it is stored over a long period of time, its capacity will decrease.

When you are using multiple batteries, alternate between the batteries.

The extent of the deterioration of a nickel metal hydride battery can be checked after charging is done, by pushing the indicator switch.

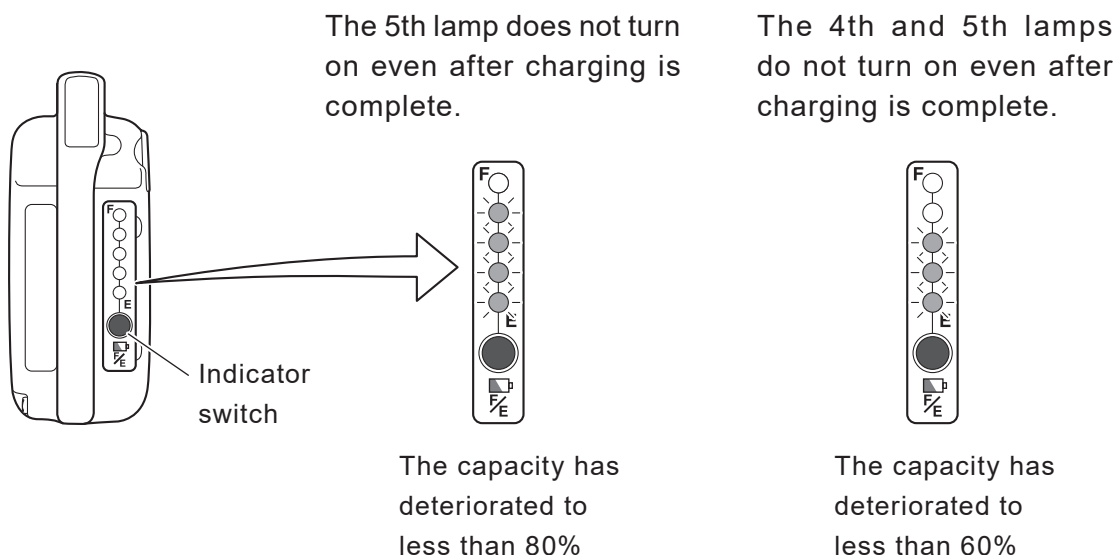



## 8.4. How to Charge the Nickel Metal Hydride Battery (JWB2)

### NOTICE

- Do not use this charger if the power cord is wound around the unit. Otherwise, the charger may overheat and be damaged.
- Make sure that the charging plug and the battery charging connector are free of dust, dirt, oil, and moisture. Also, do not insert any metallic object or other foreign substance into the plug or the connector, for this may cause the charger to malfunction or damage the battery.
- Do not place the charger in locations exposed to direct sunlight, near a heater or other heat source, or where the temperature may drop below freezing. If the charger or the battery becomes hot, the charger protection function may prevent the unit from starting or turn it off while it is charging. Also, the protection function activates if the charger is cold
- Keep the area around the charger free of other objects and do not place a cover or similar item over the unit. The charger protection function may activate if the flow of air is blocked.
- Be sure to use the genuine power cord.

#### (1) Charging time

Charging time: 2.5 – 3 hours (when charging the battery from an empty state)

Refresh charging time: 3 – 19 hours (the actual time varies depending on the residual capacity of the battery)

## (2) Charging

- ① Place the charger on a flat, stable surface with the charge indicator lamp facing up.
- ② Insert the charger plug into the charger and insert the power plug into the residential power outlet.

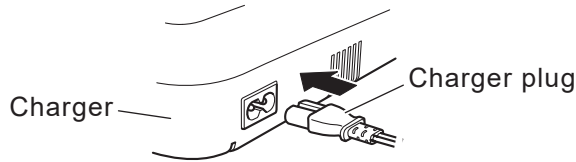
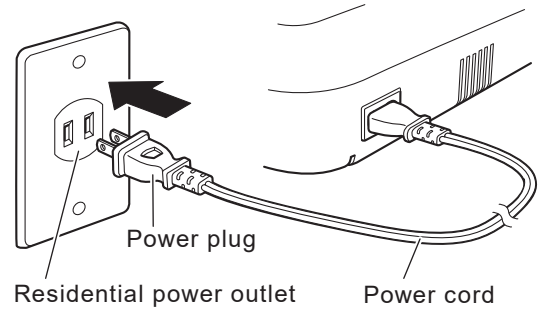

- ③ Insert the battery into the charger as shown in the diagram.

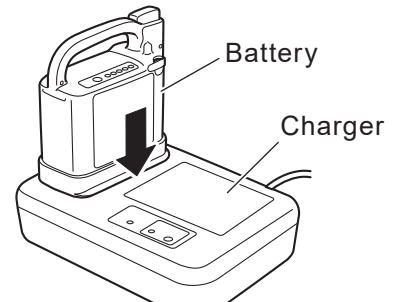

**TIP** After plugging in the charger, it takes about 5 seconds for the charging lamp to light.

- ④ The charge lamp (green) on the charger turns on, and the battery starts charging. The capacity indicator lamps on the battery flash, and the number of lamps that are lit increases according to the charging level.

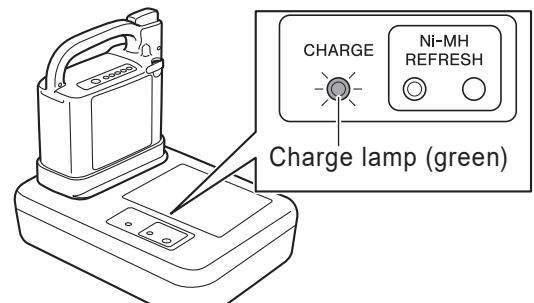

If the charge lamp (green) does not turn on, and the refresh lamp (orange) flashes, refer to “8.5. Refresh Charging the Nickel Metal Hydride Battery (JWB2)”.

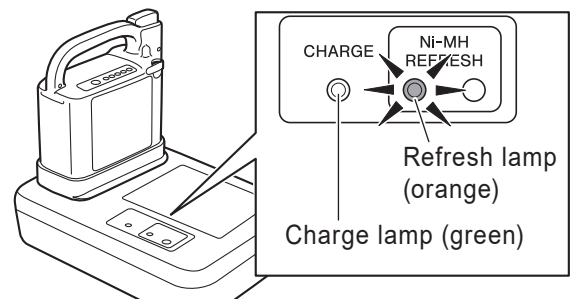

**TIP** Assuming the charging process started from an empty state, the time it takes from start to completion of the charging process is typically 2.5 to 3 hours. If charging in a location with a high temperature or if charging a brand new battery, this may take longer.

- ⑤ Check to ensure that charging is complete. When charging is complete, the battery capacity indicator lamps and the charge lamp (green) on the charger turn off.

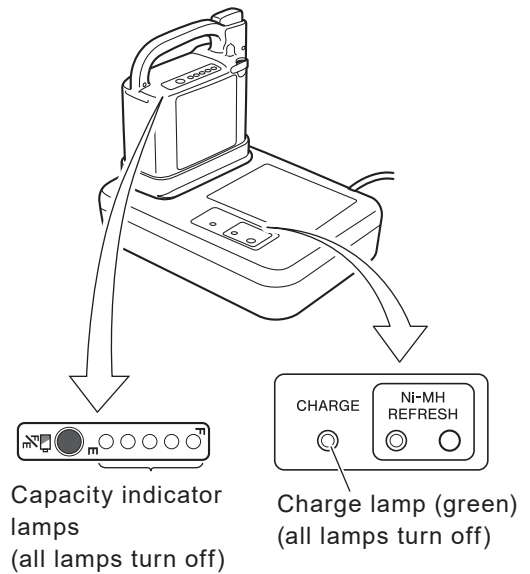

After charging is complete, you can check the charged capacity by pressing the battery indicator switch. If not all of the lamps turn on, the following could have occurred:

- While charging, the temperature of the battery rose excessively, causing the protection mechanism to abort the charging process.
- The battery deterioration has advanced and the capacity is decreasing and so on.

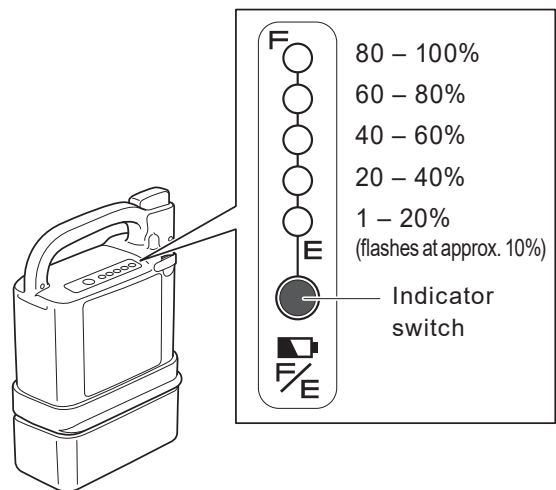

- ⑥ Unplug the power cord from the power outlet.

**NOTICE**

- Do not pull on the power cord. This can cause the wires to break.

- ⑦ Remove the battery from the charger. If you want to store the battery in this state, put the protective cap on.

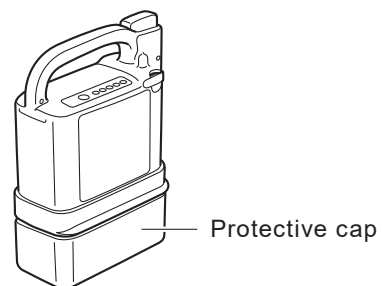



## WARNING

- Be sure to store the disconnected battery with the protective cap on it. Exposed contacts can cause short circuits and lead to a fire or battery rupture.

### TIP • If you are unable to charge the battery

Refer to “14. Troubleshooting, Repairs, Warranty”.

- If the vehicle has traveled a long distance or on a long uphill grade, or if it has been left outside in the cold for a long time, the battery temperature may not be suitable for charging.

In such a case, the charger may not start charging (remains in standby mode) until the battery has reached a suitable temperature.

8

### (3) Suitable temperature for charging

Charge the battery in an environment with a temperature of 10 to 25 °C (50 to 77 °F).

- To protect the battery, if the internal temperature of the battery is under 0 °C (32 °F) or over 40 °C (104 °F), charging does not start. Instead, it enters a standby mode. During this time, the charge lamp (green) flashes.

While in standby mode, when the battery reaches an appropriate temperature, the charge lamp will change from a flashing to an “on” state, and charging will start automatically. (The length of the standby time varies with conditions.)

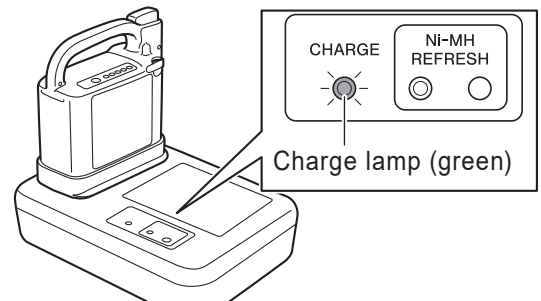
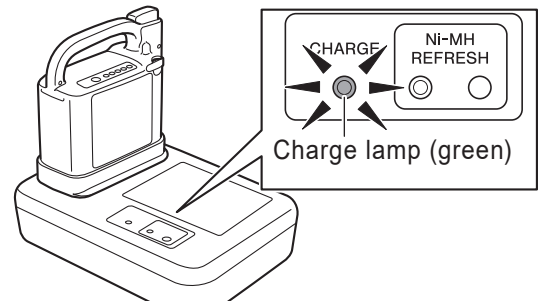

- The battery temperature increases during charging. However, if the battery temperature rises above 50 °C (122 °F), the power for the charger will turn off to protect the battery. Since charging has not ended, it is necessary to charge again after the battery temperature has decreased.

Charging a battery immediately after travel, or charging a new battery is likely to cause its temperature to increase, which increases the likelihood of the charger stopping charging before completion.

## 8.5. Refresh Charging the Nickel Metal Hydride Battery (JWB2)

A refresh charging is required on a nickel metal hydride battery to eliminate the memory effect. When the battery is inserted to the charger, if the refresh lamp (orange) on the charger flashes, press the refresh switch to perform a refresh charge cycle. (The refresh lamp flashes after every 20 to 30 charge cycles. If the refresh lamp does not flash, it is not necessary to perform a refresh charge cycle.)

(1) While the refresh lamp (orange) is flashing, press the refresh switch.

- \* The refresh lamp (orange) flashes only when refresh charging is needed.

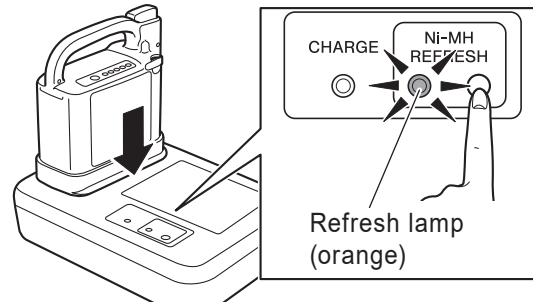

(2) The refresh lamp (orange) changes from a flashing to an “on” state, and the refresh charging starts.

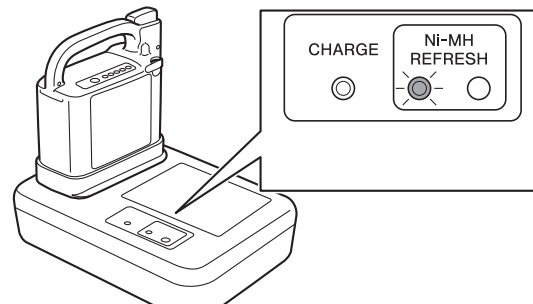

In a refresh charging process, after all remaining electricity has been discharged, the refresh lamp (orange) turns off. The charge lamp (green) comes on and a normal charging process begins. The time it takes from the start of refresh charging to the completion of normal charging is 3 – 19 hours.

- If the temperature of the battery rises during a refresh charge, the charge lamp (green) may flash and the charging process may pause.

When the battery reaches an appropriate temperature, the charge lamp will change from a flashing to an “on” state and charging will start automatically.

- If you perform a refresh recharge when the internal temperature of the battery is under 0 °C (32 °F) or over 40 °C (104 °F), it may enter a standby mode as it goes into normal charging after discharging the remaining electricity.
- Even if you fail to press the refresh switch, you can retry by momentarily removing the battery from the charger, and then reinserting the battery to see the refresh charging alert.
- If you do not press the refresh switch while the refresh lamp (orange) is flashing, the flashing refresh lamp will turn off after 1 minute. Then the charge lamp comes on and a normal charging process begins. In this case, the refresh lamp flashes again the next time you charge the battery.

**TIP Tips on charging**

- It is recommended that you charge the battery while you are sleeping.
- Since the refresh charging process recharges after discharging all of its remaining electricity, it will take a long time if you perform it on a battery with a high residual capacity. It is recommended that you perform a refresh charging on a battery that is drained as much as possible.



**8.6. Charger (ESC3) Indicator Lamps**

The charger (ESC3) for the nickel metal hydride battery has two types of lamps: the charge lamp (green) and refresh lamp (orange). Each lamp comes on or flashes to indicate the battery and charging conditions.

The lamp indications are explained in the following table.

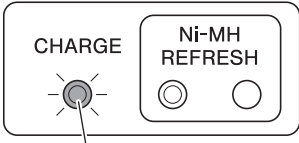
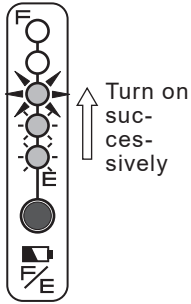
- TIP**
- Standby mode may be activated, and the charge indicator lamp may flash green once per second if the ambient temperature changes while the charger is charging. When the temperature is suitable for charging, the charge indicator lamp will stop flashing and remain on green, and the charging operation will automatically re-start.
  - If standby conditions continue for a long time, the charge indicator lamp will start flashing green rapidly (5 times per second) and the charging operation will be terminated. If this happens, unplug the charging plug and the power plug. Re-locate the charger in accordance with “8.3.(1) Ambient temperatures” and try to charge the battery again.
  - The charger protection function may be activated by a change in the ambient temperature even while charging is in progress. In this case, the charge indicator lamp will flash red and the charger will stop charging. If this happens, unplug the charging plug and the power plug. Re-locate the charger in accordance with “8.3.(1) Ambient temperatures” and try to charge the battery again.

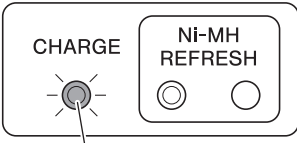
Charger lamp indication	Battery capacity indicator lamps	Description
Charge lamp (green) is on  Charge lamp (green)		Indicates normal charging. The charge lamp will turn off after charging is completed.

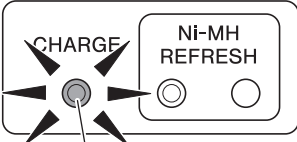
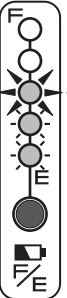
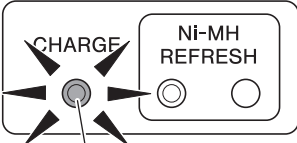
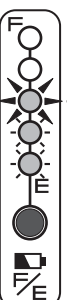
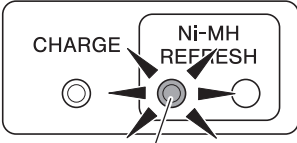
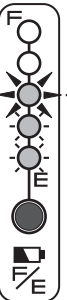
Charger lamp indication	Battery capacity indicator lamps	Description
<p>Lit or flashing red</p>  <p>Charge lamp (red)</p>	 <p>Off</p>	<p>The charger has detected a problem in the charger or the battery, and is unable to charge. Stop charging by disconnecting the charger plug and the power plug. Check the battery, charger, and cord connection for any problem, and then try charging again. If the charge lamp light comes on or flashes in red again, an equipment failure may have occurred. Stop charging by disconnecting the charger plug and the power plug, and have the equipment inspected by a dealer.</p>
<p>Charge lamp (green) is flashing (once per second)</p>  <p>Charge lamp (green)</p>	 <p>Flashing On</p>	<p>Indicates charge standby.</p> <ul style="list-style-type: none"> <li>When the temperature of the battery is not within the chargeable range 0 to 40 °C (32 to 104 °F), the charger enters a standby state and the charge lamp (green) starts flashing.</li> <li>Once the battery temperature falls within the chargeable range during standby, charging will start automatically and the charge lamp (green) changes from a flashing to an “on” state. However, if the charge standby condition continues for a long time, charging will end, and the power for the charger will turn off.</li> </ul>
<p>Charge lamp (green) is flashing (5 times per second)</p>  <p>Charge lamp (green)</p>	 <p>Flashing On</p>	<p>Indicates timeout of charge standby.</p> <ul style="list-style-type: none"> <li>The charger has remained in standby mode for a long time and has stopped charging the battery. Re-locate the charger and try to charge the battery again.</li> </ul>
<p>Refresh lamp (orange) is flashing</p>  <p>Refresh lamp (orange)</p>	 <p>Flashing On</p>	<p>Refresh charging is being requested. While the refresh lamp is flashing, press the refresh switch to perform a refresh charge cycle. If you do not press the refresh switch, a normal charging begins after 1 minute.</p>

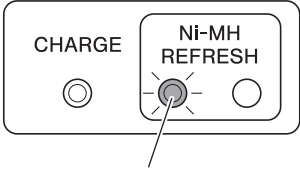
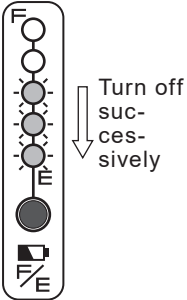
Charger lamp indication	Battery capacity indicator lamps	Description
<p data-bbox="165 210 568 244">Refresh lamp (orange) is on</p>  <p data-bbox="240 454 507 488">Refresh lamp (orange)</p>	 <p data-bbox="730 300 826 398">Turn off successively</p>	<p data-bbox="879 210 1262 244">Indicates refresh charging.</p> <p data-bbox="879 248 1485 405">The remaining electricity is being discharged as part of the refresh charging process. When the discharge has completed, normal charging will start.</p>



# 9. Lithium Ion Battery and Charger

## 9.1. Features of the Lithium Ion Battery (ESB1)

- Has a higher energy capacity compared to the nickel metal hydride battery.
- Equipped with Battery Management Control System (BMC). (built-in microprocessor) This is a system that uses a computer to track charge/discharge status, operating conditions, and temperature.
- Even with repeated shallow discharge/charge cycles, it is difficult for the memory effect to occur. Therefore, refresh charging is not necessary, and its charges can be replenished additively.
- Battery does not contain mercury or cadmium.
- Compact but high capacity.

## 9.2. How to Use the Lithium Ion Battery (ESB1)

- (1) Attaching and removing the battery to and from the wheelchair

For instructions on attaching and removing the lithium ion battery to and from the wheelchair, see “4. Riding the Wheelchair” and “5. After You are Finished Riding the Wheelchair”.

- (2) Checking the residual capacity of the battery

Press the indicator switch to display the battery’s residual capacity.

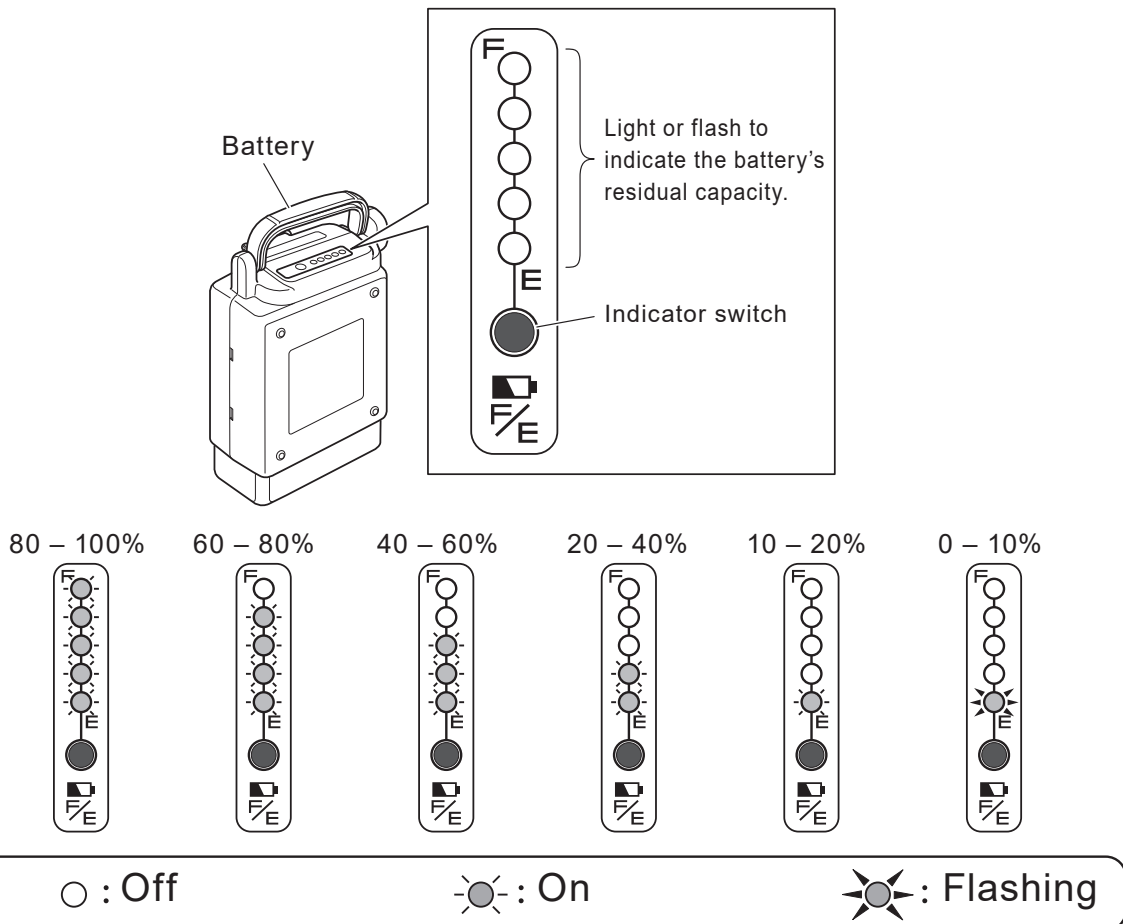

### (3) Storing the battery

Store batteries in a cool, dry area. (For the temperature, refer to “9.3. Characteristics and Handling of the Lithium Ion Battery (ESB1)”)

If you are not planning on using the battery for a long period of time (30 days or more), charge it so that 3 of the capacity indicator lamps comes on, and then store it.

To store the battery without using it for over 3 months, check every 3 months to see if 3 capacity indicator lamps light up.

If 2 or less lamps turn on, charge the battery until 3 lamps turn on.

Always put on the protective cap when storing the battery.

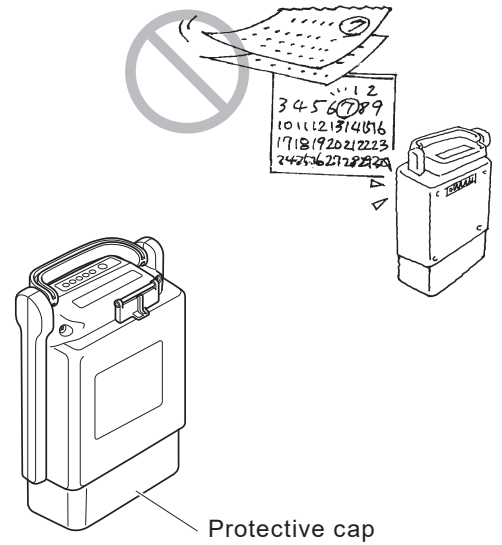

#### WARNING

- **Be sure to store the disconnected battery with the protective cap on it. Exposed contacts can cause short circuits and lead to a fire or battery rupture.**

#### TIP • **If you are unable to charge the battery**

Refer to “14. Troubleshooting, Repairs, Warranty”.

- If the vehicle has traveled a long distance or on a long uphill grade, or if it has been left outside in the cold for a long time, the battery temperature may not be suitable for charging.  
In such a case, the charger may not start charging (remains in standby mode) until the battery has reached a suitable temperature.

## 9.3. Characteristics and Handling of the Lithium Ion Battery (ESB1)

### (1) Ambient temperatures

#### <Recommended temperature>

When in use on the wheelchair: Temperature range between 0 to 35 °C (32 to 95 °F)
When removed from wheelchair and stored: Temperature range between 10 to 25 °C (50 to 77 °F)
When charging: Temperature range between 10 to 25 °C (50 to 77 °F)

- Storing the battery in excessively high or low temperatures will speed up its degradation, and its capacity will rapidly decrease.
- Using the wheelchair in excessively high or low temperatures will cause the battery deterioration to speed up and its capacity to rapidly decrease. For information on degradation, see “Battery’s deterioration characteristics” on the next page.

#### <Available temperature>

When in use on the wheelchair: Temperature range between -25 to 50 °C (-13 – 122 °F)
When removed from wheelchair and stored: Temperature range between -40 to 65 °C (-40 – 149 °F)
When charging: Temperature range between 0 to 40 °C (32 – 104 °F)

If the temperature inside the battery is below 0 °C (32 °F) or above 45 °C (113 °F) and regenerative current is detected, an error is displayed and the wheelchair stops. And depending on the ambient temperature, the distance that can be traveled becomes shortened and the battery deterioration will be accelerated. To maximize battery performance, use the battery under the “Recommend temperature” conditions.

**TIP** If the internal temperature of the Li-ion battery becomes below 0 °C (32 °F) or above 45 °C (113 °F) while the wheelchair is in operation, the LCD indication will change to a warning and a buzzer will sound.

Depending on conditions, the wheelchair may stop during operation.

Avoid operating the wheelchair with the battery in the following conditions.

- Batteries that have been stored in direct sunlight or in a car, etc., and the internal temperature has risen.
- Batteries that have been stored in a place where the air temperature is below 0 °C (32 °F) and the internal temperature has dropped.

- **Warning for Abnormal Internal Temperature**

If the internal temperature of the battery remains below

0 °C (32 °F) or above 45 °C (113 °F) for 5 seconds or more, "C9" will flash on the LCD screen accompanied by continuous short "beeping" sound.



- **Stopping the Wheelchair**

With the "C9" warning activated, the wheelchair may stop to protect the battery if the battery is being charged by movements such as going down a slope or decelerating.

In this case, if the temperature is below 0 °C (32 °F), the wheelchair will stop with a long "beep" and the LCD screen will alternately display "E1" and "22".

If the temperature is above 45 °C (113 °F), the wheelchair will stop with a long "beep" and the LCD screen will display "E".

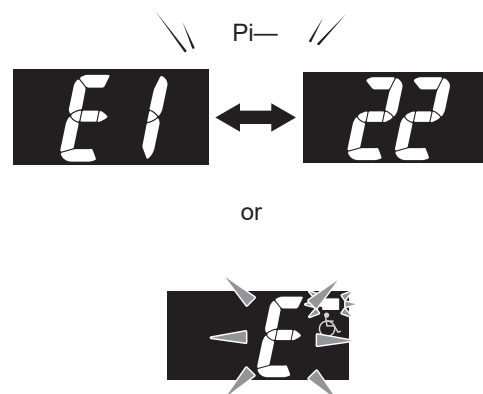

## (2) Battery's deterioration characteristics

All batteries are consumables. A battery gradually deteriorates and its capacity decreases over time and with use.

The extent to which the capacity decreases by deterioration depends on the use conditions.

**TIP** For a lithium ion battery, its capacity will decrease to approximately 60% of that of a new battery after 700 charge cycles, under normal use.

Even if a battery is not used, when it is stored over a long period of time, it will deteriorate and its capacity will decrease.

When you are using multiple batteries, alternate between the batteries.

**TIP** Immediately after the lithium ion battery has successfully completed charging (fully charged), pushing the indicator switch will always show all 5 lamps lit. Even if deterioration has progressed, all 5 lamps should turn on when fully charged. This display format was adopted for this battery, as the rate of deterioration of lithium ion batteries is gradual.

### (3) The life of the lithium ion battery

The life of the lithium ion battery (ESB1) is 8 years from its initial charging, 8,000 Ah of integral charge capacity or the battery deterioration level drops below 25%. \*

\* Battery Deterioration Level is a measure of battery degradation expressed as a ratio of capacity to new capacity.

- **Battery life alert**

The capacity indicator lamps start alerting you from 3 months prior to the battery becoming no longer chargeable due to its end-of-life, or when the integral charge capacity reaches 7,800 Ah or the battery deterioration level drops below 50%. When charging has completed and the charger plug is unplugged, the capacity indicator lamps turn on and off as shown in the figure on the right.

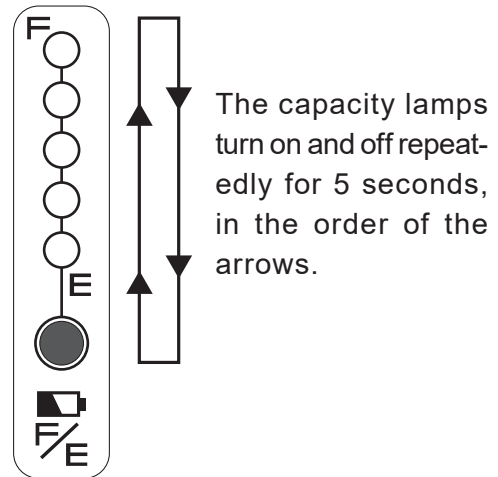

- **When the battery reaches end of life**

Once the battery reaches its end of life, the lamp on the charger will not turn on when attempting to charge the battery. Moreover, the battery's capacity indicator lamps no longer turn on and the battery cannot be charged.

**TIP If you forget the date you started to use the lithium ion battery.**

The battery's manufactured date is printed on its bottom. Use it as a reference.

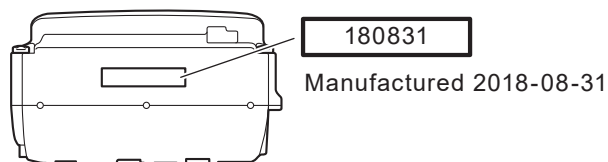

- The start date of battery usage is defined as the date the user charged the battery for the first time after shipment from the factory.

(This does not match the manufactured date above.)

- Once the integral charge capacity reaches 8,000 Ah, the battery will not be usable even if it has not been 8 years.

- \* The integral charge capacity of 8,000 Ah is approximately 700 times the capacity of the "ESB1" lithium ion battery (hence equivalent to approximately 700 charge cycles, when fully charged from 0 residual capacity).

## 9.4. How to Charge the Lithium Ion Battery (ESB1)

There are two ways to charge the battery; by removing it from the wheelchair (tabletop charging), or while it is still attached to the wheelchair (on-vehicle charging).

### NOTICE

- Do not use this charger if the power cord is wound around the unit. Otherwise, the charger may overheat and be damaged.
- Make sure that the charging plug and the battery charging connector are free of dust, dirt, oil, and moisture. Also, do not insert any metallic object or other foreign substance into the plug or the connector, for this may cause the charger to malfunction or damage the battery.
- Do not place the charger in locations exposed to direct sunlight, near a heater or other heat source, or where the temperature may drop below freezing. If the charger or the battery becomes hot, the charger protection function may prevent the unit from starting or turn it off while it is charging. Also, the protection function activates if the charger is cold.
- Keep the area around the charger free of other objects and do not place a cover or similar item over the unit. The charger protection function may activate if the flow of air is blocked.
- Be sure to use the genuine power cord.

9

#### (1) Charging time

Charging time: Approx. 4 hours (when charging the battery from an empty state)

#### (2) Charging the battery out of the unit (tabletop charging)

- ① Place the charger on a flat, stable surface with the charge indicator lamp facing up.
- ② Check that the protective cap is on the battery. If the protective cap is not attached, be sure to attach it.

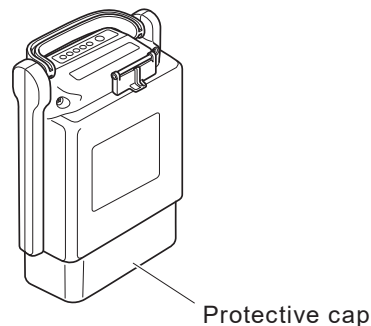

- ③ Insert the power plug of the dedicated charger (ESC3) into the residential power outlet.

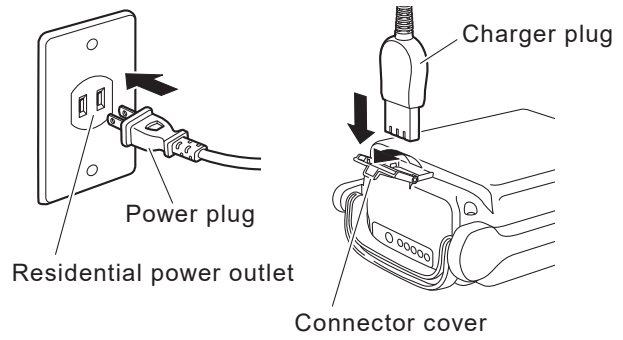

**TIP** After plugging in the charger, it takes about 5 seconds for the charging lamp to light.

- ④ Rest the battery on its side.
- ⑤ Open the connector cover, and insert the charger plug into the charge connector on the battery.
- ⑥ Check that the charge lamp (green) on the charger turns on. If the charge lamp does not light green, see “9.6. Charger (ESC3) Indicator Lamps”.
- ⑦ While charging, you can check the charge status using the capacity indicator lamps on the battery. The capacity indicator lamps will turn off after charging has completed. Assuming that charging started with the battery in an empty state, the time to completion is typically 4 hours.

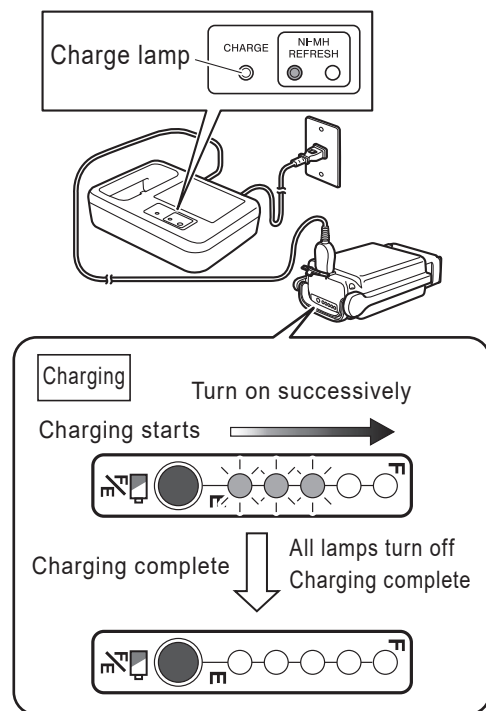

- ⑧ After charging has completed, unplug the charger plug and the power plug, then securely close the battery's connector cover.

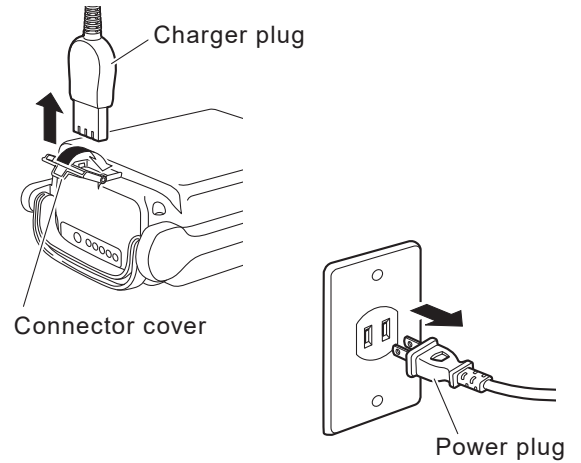

### NOTICE

- Do not pull on the power cord. This can cause the wires to break.

9

### (3) Charging the battery attached to the wheelchair (on-vehicle charging)

- ① Prepare for charging.

Remove any bags and luggage from the backrest, and anything else that can potentially tangle the charge cable.

Park the wheelchair indoor on a level floor, and apply the parking brakes.

- ② Turn off the power switch on the wheelchair.

As a safety measure, during on-vehicle charging, the wheelchair will not power on even if it is switched on.

- ③ Insert the power plug of the dedicated charger (ESC3) into the residential power outlet.

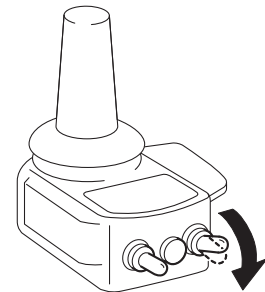

- ④ Open the connector cover, and insert the charger plug into the charge connector on the battery.

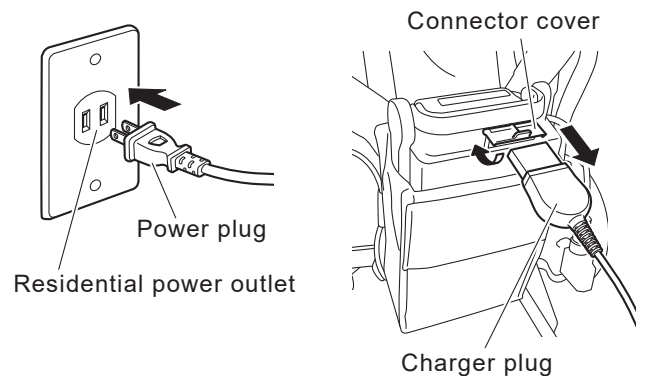



- ⑤ Check that the charge lamp (green) on the charger turns on.  
If the charge lamp does not come on green, see “9.6. Charger (ESC3) Indicator Lamps”.

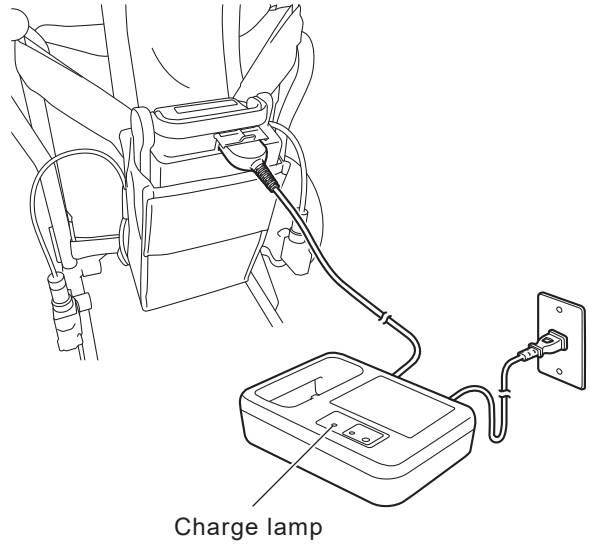

- ⑥ While charging, you can check the charge status using the capacity indicator lamps on the battery.  
The capacity indicator lamps will turn off after charging has completed.  
Assuming that charging started with the battery in an empty state, the time to completion is typically 4 hours.

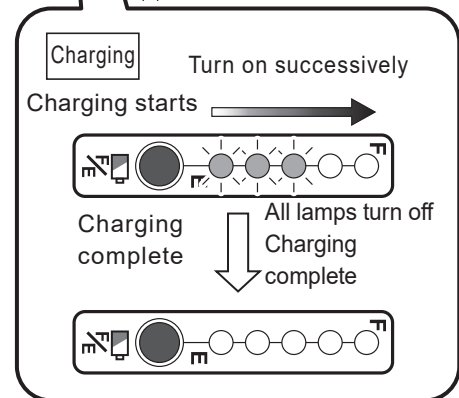
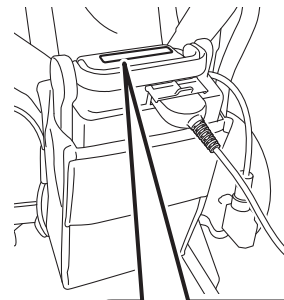

- ⑦ After charging has completed, unplug the charger plug and the power plug, then securely close the battery's connector cover.

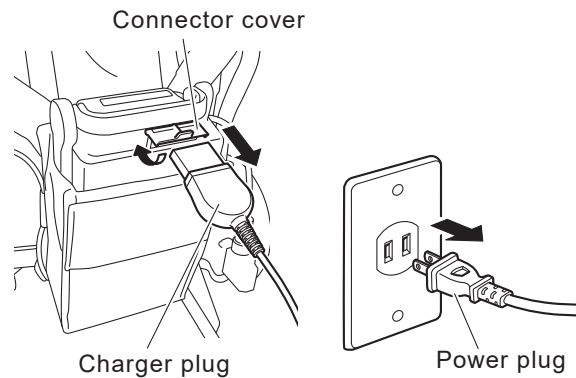

### NOTICE

- Do not pull on the power cord. This can cause the wires to break.

## 9.5. The Temperature of the Lithium Ion Battery (ESB1) during Charging

Charge the battery in an environment with a temperature of 10 to 25 °C (50 to 77 °F).

- To protect the battery, if the internal temperature of the battery is under 0 °C (32 °F) or over 40 °C (104 °F), charging does not start. Instead, it enters a standby mode. During this time, the charge lamp (green) flashes.

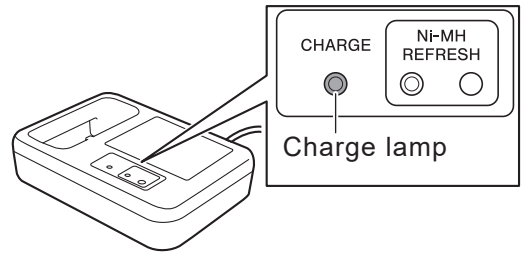

While in standby mode, when the battery reaches an appropriate temperature, the charge lamp (green) will change from a flashing to an “on” state, and charging will start automatically. (The length of the standby time varies with the conditions.)

- The battery temperature increases during charging. However, if the battery temperature rises above 45 °C (113 °F), the power for the charger will turn off to protect the battery.

Since charging has not ended, it is necessary to charge again after the battery temperature has decreased.

Charging a battery immediately after travel, or charging a new battery is likely to cause its temperature to increase, which increases the likelihood of the charger stopping charging before completion.

## 9.6. Charger (ESC3) Indicator Lamps

The charger (ESC3) for the lithium ion battery has a charge lamp to indicate the battery and charging conditions according to the lamp's color and whether it is on or flashing. The lamp indications are explained in the following table.

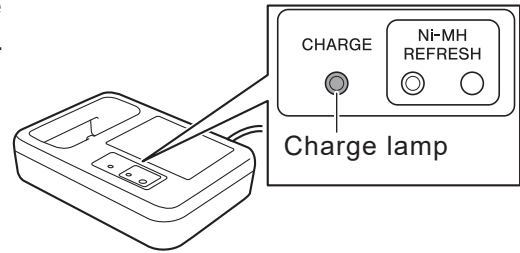

Charger lamp indication	Battery capacity indicator lamps	Description
<p><b>Lit green</b></p> <p>Charge lamp (green)</p>		<p>Indicates normal charging. The charge lamp will turn off after charging has completed.</p>
<p><b>Flashing green (once per second)</b></p> <p>Charge lamp (green)</p>		<p>Indicates charge standby.</p> <ul style="list-style-type: none"> <li>When the temperature of the battery is not within the chargeable range 0 to 40 °C (32 to 104 °F), the charger enters a standby state and the charge lamp starts flashing in green.</li> <li>Once the battery temperature falls within the chargeable range during standby, charging will start automatically and the charge lamp (green) changes from a flashing to an "on" state. However, if the charge standby condition continues for a long time, charging will end. When this happens, the charge lamp flashes rapidly in green.</li> </ul>
<p><b>Flashing green (5 times per second)</b></p> <p>Charge lamp (green)</p>		<p>Indicates timeout of charge standby.</p> <ul style="list-style-type: none"> <li>The charger has remained in standby mode for a long time and has stopped charging the battery. Re-locate the charger and try to charge the battery again.</li> </ul>
<p><b>Lit or flashing red</b></p> <p>Charge lamp (red)</p>	<p>Off</p>	<p>The charger has detected a problem in the charger or the battery, and is unable to charge. Stop charging by disconnecting the charger plug and the power plug. Check the battery, charger, and cord connection for any problem, and then try charging again. If the charge lamp light comes on or flashes in red again, an equipment failure may have occurred. Stop charging by disconnecting the charger plug and the power plug, and have the equipment inspected by a dealer.</p>

# 10. Wheelchair Transporting and Storing Instructions

Please refer to the Warnings in “1.5.15. Transporting and Storing the Wheelchair” on page 17 to 18.

## 10.1. Loading the Wheelchair in a Car

- (1) Turn off the power of the wheelchair.

- (2) Remove the battery.  
Be sure to remove the battery from the wheelchair so that its power will not turn on unexpectedly during transport.  
Be sure to put the protective cap on the removed battery.

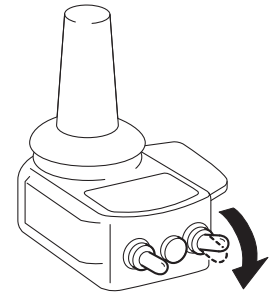

- (3) Lock the wheels.  
Set the left and right clutch levers to the power drive position so that the wheels will not spin, and then apply the parking brakes.
- (4) Remove any detachable parts.  
Remove the foot-leg supports and any other parts that can be detached.
- (5) Detach the drive units.  
If necessary, detach the drive units from wheelchair frame.  
Refer to “11.1. Removing and Installing the Unit” (pages 83 to 86).
- (6) Fold the wheelchair.  
If necessary, fold the wheelchair.

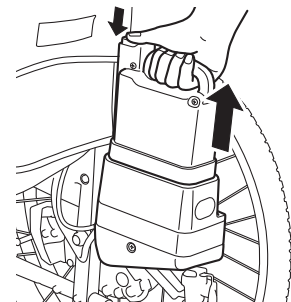



## WARNING

- **Be sure to store the disconnected battery with the protective cap on it. Exposed contacts can cause short circuits and lead to a fire or battery rupture.**

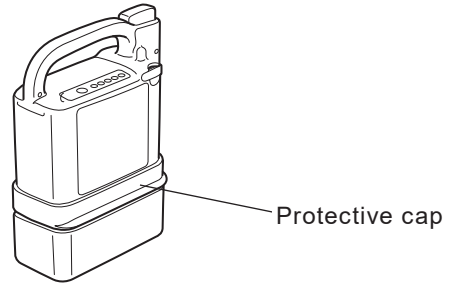

- (7) Load the wheelchair into the car.  
Gently load the wheelchair by holding the frame portion with both hands.
- (8) Secure the wheelchair.  
Secure the wheelchair to prevent it from moving or hitting any surrounding objects.

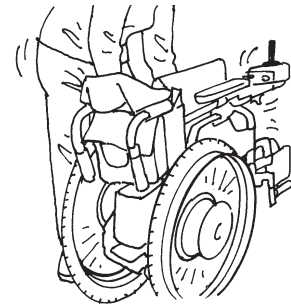

### TIP When loading:

- This product uses precision electronic parts. Do not apply sharp impact.
- Load it upright whenever possible.
- If loading it on its side, place it so that the controller is at the top. Secure the wheelchair, ensuring that the controller is not hitting against any surrounding object.

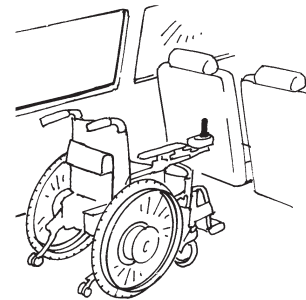

### TIP Securing the Wheelchair:

- Strap it down with a belt, etc., or place a shock absorbing material under and around the wheelchair.

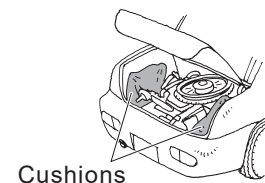

## 10.2. Unloading the Wheelchair from a Car

- (1) Unload the wheelchair from the car.

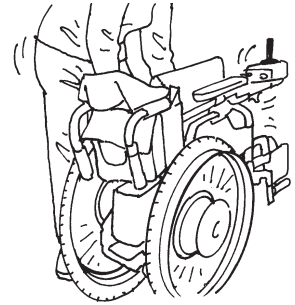

- (2) Reattach the removed parts, detached units back to their original places, and unfold the wheelchair.

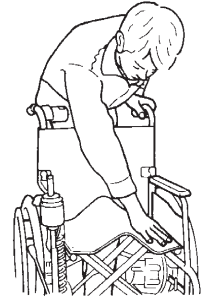

- (3) Check that the parking brakes are applied.
- (4) Check that the anti-tip device is in the correct position.

### TIP When unloading:

- This product uses precision electronic parts. Do not apply sharp impact.



### WARNING

- If the foot-leg supports are removed or foldable parts are folded, be sure to place them in their original positions before operating the wheelchair. Never operate the wheelchair with parts removed or folded. You may injure yourself.
- If the anti-tip device is folded or its safety wheels are facing upwards, be sure to place it in its original position and confirm that it is locked before operating the wheelchair. Never operate the wheelchair with the anti-tip device folded or its safety wheels facing upwards. You may injure yourself.

## 10.3. Storing the Wheelchair

- (1) Apply the parking brakes and set the left and right clutch levers in the power drive position.
- (2) Turn off the power and remove the battery.

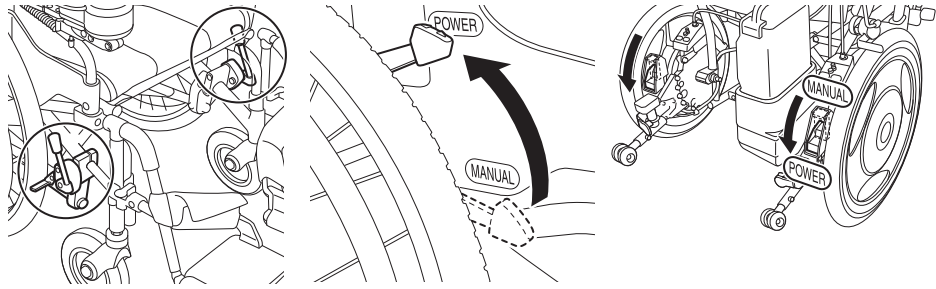

- (3) Store the wheelchair indoors where there is less humidity.
- (4) To wipe off dirt or spots before storing, use a tightly wrung-out towel.
- (5) If the wheelchair will not be used for more than 3 months, inflate the tires to the specified pressure, install the battery, and confirm that the wheelchair operates correctly every 3 months.

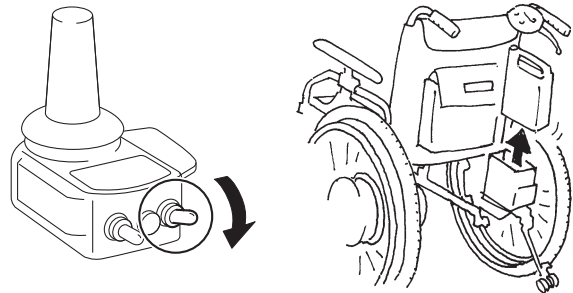

### WARNING

- Be sure to remove the battery when not in use, so that its power will not turn on unexpectedly in storage.
- Be sure to store the disconnected battery with the protective cap on it. Exposed contacts can cause short circuits and lead to a fire or battery rupture.

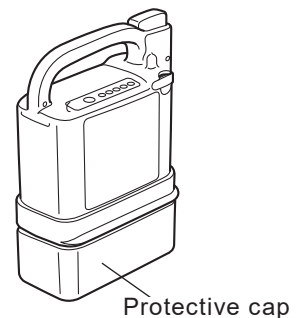

**TIP** When storing the battery for a long period of time, see sections below, and observe the cautionary notes.

- For the nickel metal hydride battery "8.2. (3) Storing the battery"
- For the lithium ion battery "9.2. (3) Storing the battery"

Please refer to the Warnings in "1.5.15. Transporting and Storing the Wheelchair" on page 17 to 18.

## 10.4. Boarding an Airplane

Once your plane trip has been determined, inform your airline company in advance, that you will be using an electric wheelchair, and follow their instructions. At this time, provide the airline company with details of your wheelchair. In particular, see the specifications for the battery you are using, below:

- Nickel metal hydride battery (shown as “Ni–MH” on the label)
  - Model JWB2
  - Voltage 24 V
  - Capacity 6.7 Ah
  - Type Dry cell with a built-in microcomputer
- Lithium ion battery (shown as “Li–ion 22” on the label)
  - Model ESB1
  - Voltage 25.2 V
  - Capacity 10.08 Ah (254 Wh)
  - Type Dry cell with a built-in microcomputer

### About the lithium ion battery

There may be restrictions in regard to carrying the lithium ion battery on-board, or checking-in as a baggage. Be sure to consult with the airline company in advance.



# 11. Using the Wheelchair more Comfortably

The iXpress has a variety of features to improve its controllability. Use these features according to your purposes. For information on the wheelchair frame to which iXpress is attached, see the owner's manual from the frame manufacturer.

## 11.1. Removing and Installing the Unit

The power units of the iXpress can be removed from the frame when replacing the current wheels with manual wheels or when transporting the wheelchair.

### (1) Removing the power units from the frame

- ① Turn off the power and remove the battery. Put the protective cap on the removed battery.

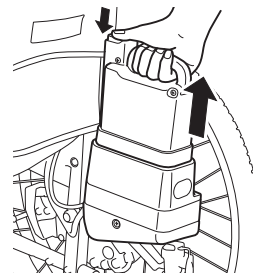
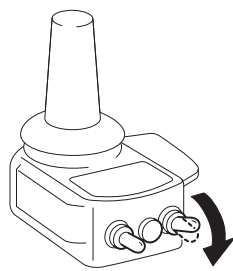

- ② Switch the left and right clutches to the power drive position.

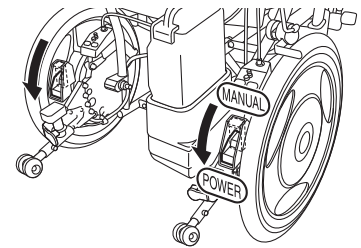
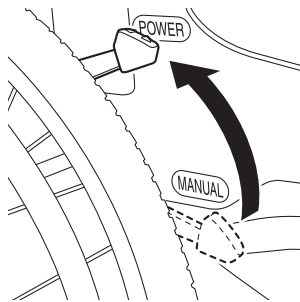

- ③ Turn the connector ring at the end of the cable counterclockwise while pulling the connector up to disconnect the cable.

Connector

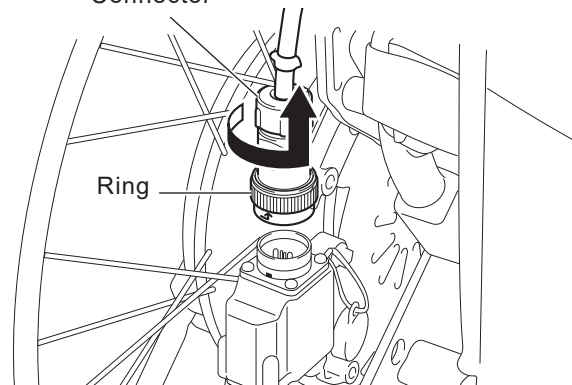

Ring

**TIP** On models that feature an integrated battery seat, the connector is located on the left wheel. On models that feature a detachable battery seat, and on the JW Swing, a connector is located on both the left and right wheel.

- ④ Attach the cap to prevent dirt or water from entering the connector.

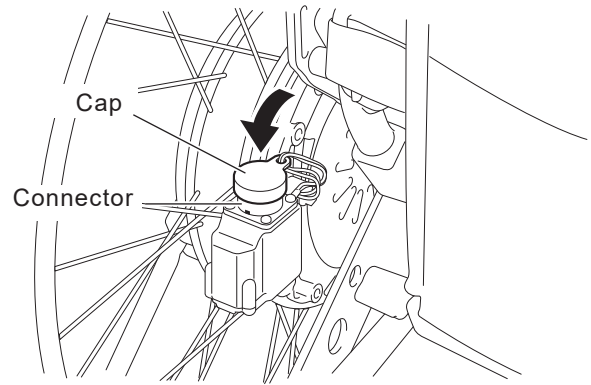

- ⑤ Place the wheelchair so that it will not become unstable when the power units are removed. (For example, as shown in the figure.)

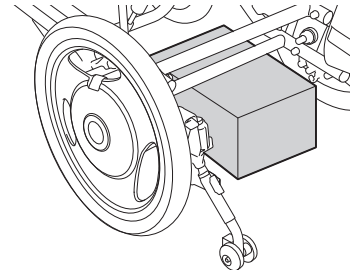

- ⑥ Release the parking brakes.

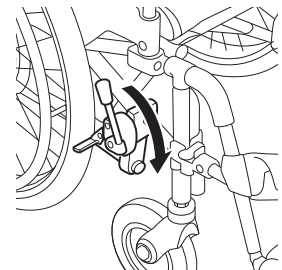

- ⑦ While holding the hub with both hands and pushing the middle of the center cap "a" with your fingers, pull out each power unit using both hands.

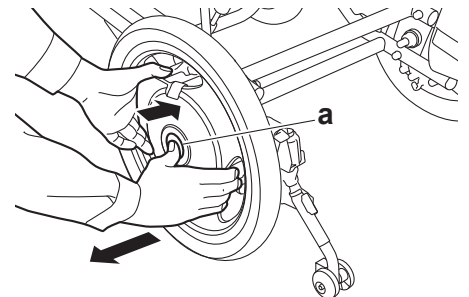

# 11

## (2) Installing the power units to the frame

- ① Place the wheelchair so that it will not become unstable. (For example, as shown in the figure.)

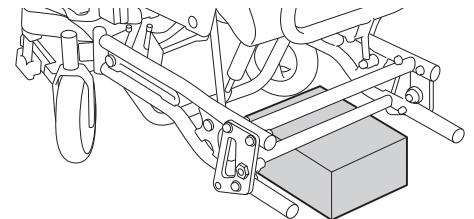

- ② Switch the clutches on the units to the power drive position.

- ③ While pushing the middle of the center cap "a" with your fingers, install each power unit using both hands so that the torque stopper axle "b" fits into the torque-receiving component.

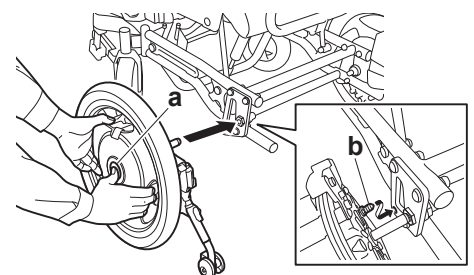

- ④ Push in each power unit completely. Check to ensure that the two balls “a” on the end of the axle can be seen completely.

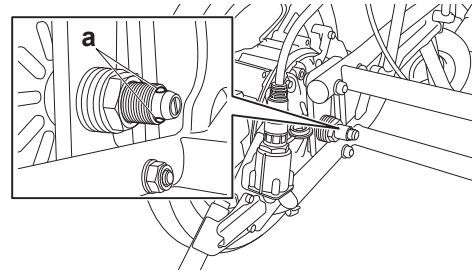

- ⑤ Pull each power unit to ensure that it will not come off.

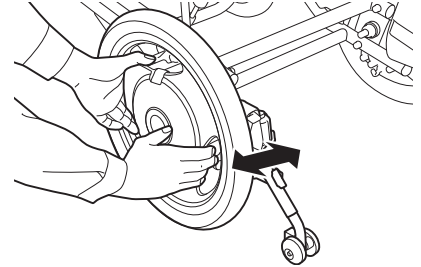

- ⑥ Place the power units in their normal position, and then apply the parking brakes.

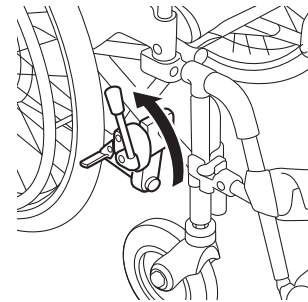

- ⑦ Remove the cap from the connector on the left wheel.

- ⑧ Align the white dot (arrow mark) on the connector at the end of the cable with the white dot on the connector on the wheel side, and then push in the cable connector until it clicks.  
Connect the cable with an L mark to the connector with an L mark (on the wheel side), and connect the cable with an R mark to the connector with an R mark (on the wheel side).

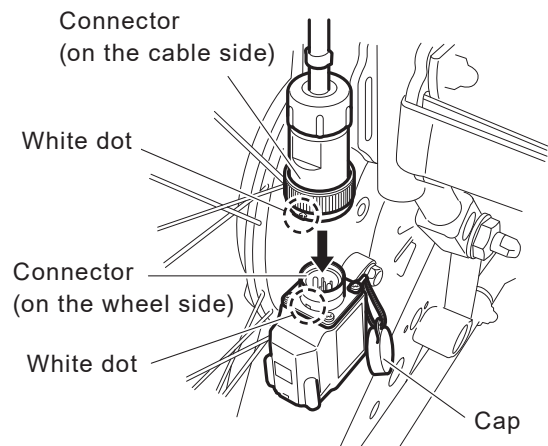

- ⑨ Make sure that the connector will not be disconnected.

### NOTICE

- When you install the right wheel on models that feature an integrated battery, support the battery storage compartment to prevent the wheel from turning. Otherwise, the wheel might turn, possibly causing damage to the switch or the battery storage compartment.

⑩ Install the battery.

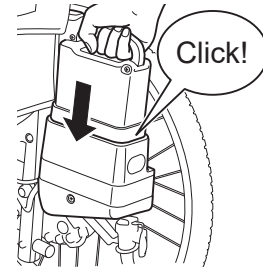

### WARNING

- When a person is sitting in the wheelchair, do not remove or install the wheels. The person riding in the wheelchair or people around the wheelchair may get injured.
- After the power units are installed to the frame, be sure to check that the balls on the end of each axle can be seen, and that the units will not come off if pulled. If the axles are not secured, the axles could suddenly come off while the wheelchair is traveling and the wheelchair could tip over, causing serious injury.

## 11.2. Anti-tip Device

The anti-tip device of the iXpress can be folded. Do so when going over bumps with the assistant operations. Immediately after going over a bump, return the anti-tip device to its original position.

### (1) Retracting the anti-tip device

Turn the anti-tip device inward while the lock lever is pushed.

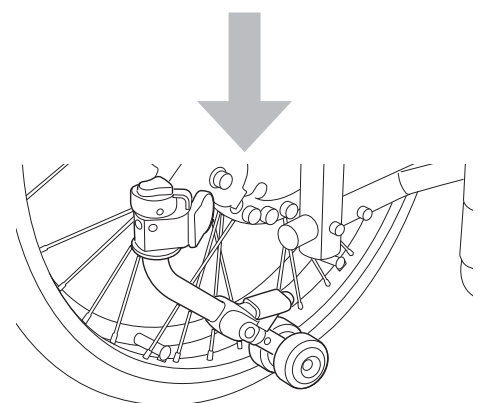
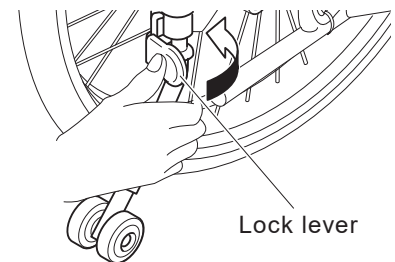

- (2) Returning the retracted anti-tip device to its original position

Turn the anti-tip device outward without touching the lock lever until you hear a click.

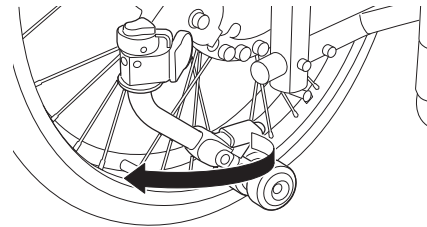

Make sure that the anti-lock device is locked in position.

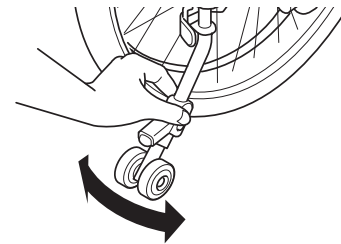

## WARNING

- Operating the wheelchair when the anti-tip device is removed or not in the correct position may cause a rollover. Make sure you operate the wheelchair with the safety wheels facing downwards.
- Only have the safety wheels facing upwards when going over bumps with the assistant operations and other such situations.
- Make sure you return the safety wheels to the correct position after going over the bump.
- A road surface with large depressions can cause a rollover, even if the safety wheels are facing downwards. When going over bumps, also pay close attention to the condition of the road surface.
- Even if the anti-tip device is in the correct position, the wheelchair could rollover due to various factors, such as a bumpy road surface, holes, level differences, and slopes.  
Make sure that the road you use frequently on a daily basis is safe beforehand.

## 11.3. Controller Holder

Handling of the controller holders is difference depends on their type.

- **Adjusting the mounting position of the controller**

The Mounting position and angle of the controller can be adjusted.

Consult with your dealer on this adjustment.

- **Retracting the controller**

The controller can be retracted. Retract the controller to move close to a table or desk.

- **Vertical type controller holders (Standard)**

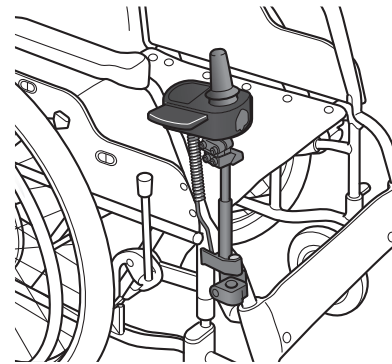

- **Parallel arm type controller holders (Optional)**

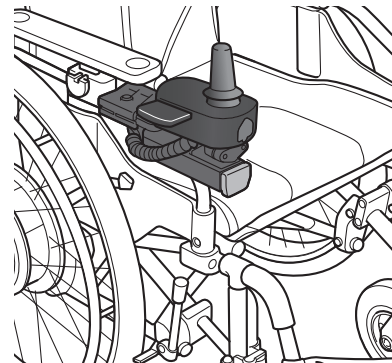

- **Horizontal type controller holders (Optional)**

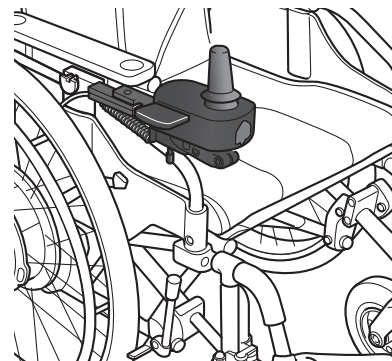

**⚠ WARNING**

- Do not remove the controller from the upper holder with the power on, and do not turn on the power after removing it. The joystick may tilt, causing the wheelchair to move unexpectedly, and this may result in injury to you or other people in your surrounding area.
- Never travel in power drive mode with the controller removed from the upper holder. Also, do not remove the controller from the upper holder while traveling. You may not be able to control the wheelchair properly, and you or other people in your surrounding area may get injured.

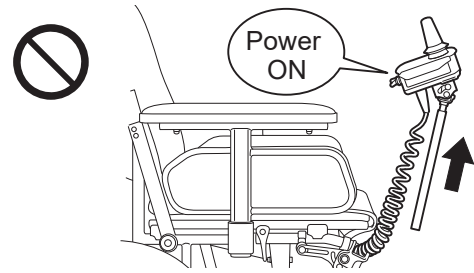

- Do not retract or pull out the controller from holder with the power on, and do not turn on the power after retracting or pulling out it. The joystick may tilt, causing the wheelchair to move unexpectedly, and this may result in you or other people in your surrounding to getting injured.
- Never travel in power drive mode with the controller retracted or pulled out. Also do not retract or pull out the controller while traveling. You may not be able to control the wheelchair properly, and you or other people in your surrounding may get injured.

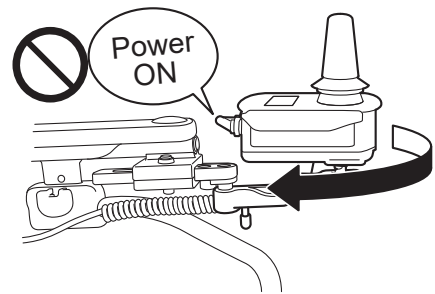

- If the controller is adjusted outside the hand-rim, pay attention to surrounding people and walls. Other people around you may get injured and other obstacles around you may get damaged.

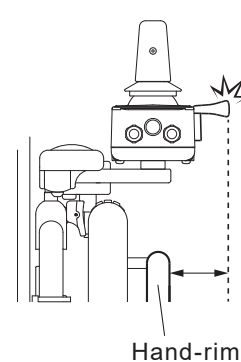

### 11.3.1. Vertical type controller holders (Standard)

#### Adjusting the mounting position of the controller

The Mounting position and angle of the controller can be adjusted.

Consult with your dealer on this adjustment.

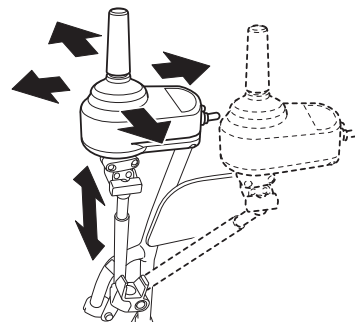

#### How to retract the controller

(1) Turn off the power switch.

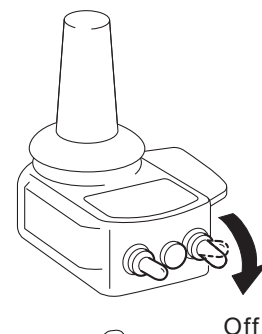

(2) Move the upper holder lock lever outward.

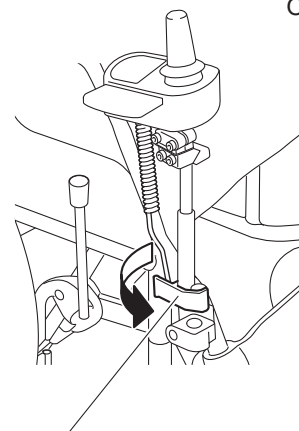

(3) Pull the controller upward to remove it.

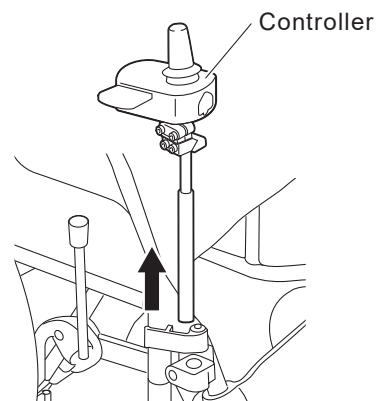



(4) Insert the controller into the lower holder.

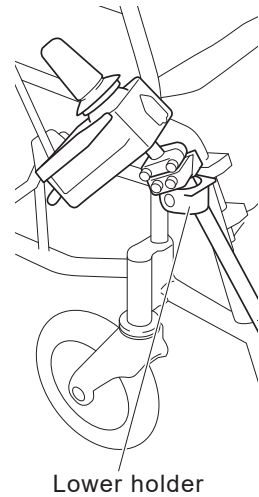

(5) To return the controller to its original position, reverse the procedure.

### 11.3.2. Parallel arm type controller holders (Optional)

#### Adjusting the mounting position of the controller

- Adjusting the Horizontal position  
The Mounting position can be adjusted for 3 positions of Center, inner and outer side.

(1) Turn off the power switch.

(2) Adjusting the position of controller while the lock lever of the holders is pulled up.

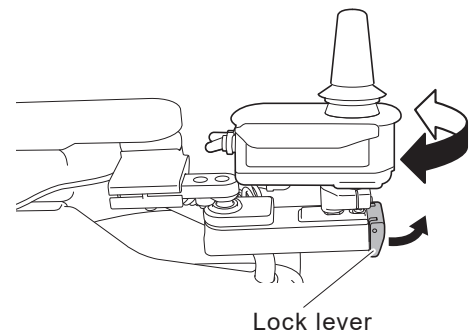

(3) After release the lock lever, the controller position is fixed with lock position.

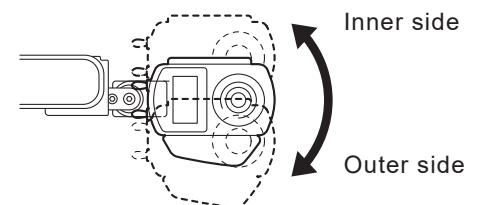

- Adjusting the Forward/Backward, angle and direction  
Consult with your dealer on this adjustment.

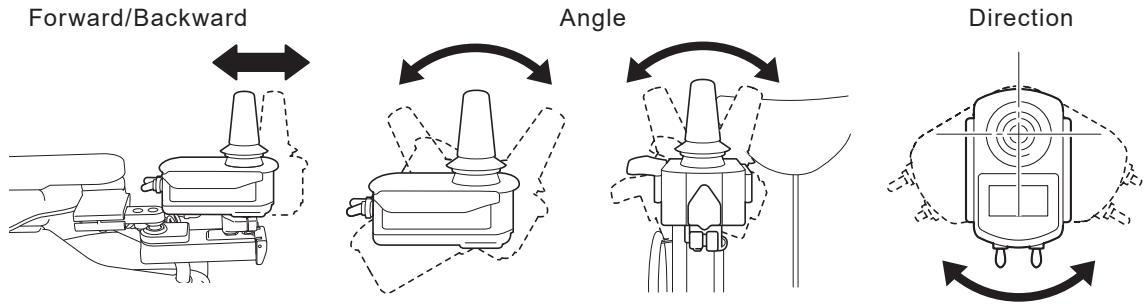

### How to retract the controller

- (1) Turn off the power switch.

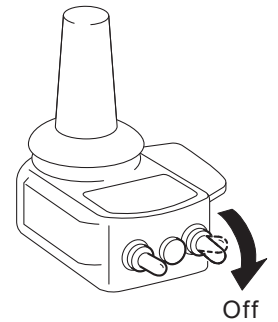

- (2) Moving the controller with pulling up the Lock lever.

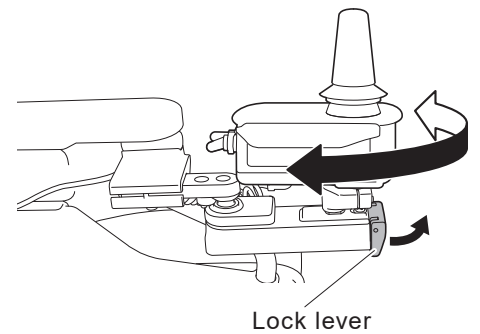

- (3) The moving range is wider than the range of the fixed position.

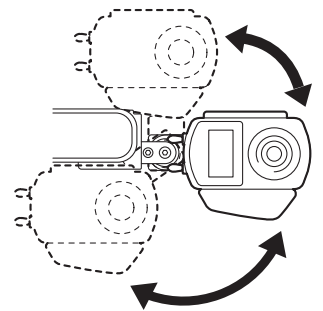

### 11.3.3. Horizontal type controller holders (Optional)

Adjusting the mounting position of the controller

- Adjusting the position, angle and direction  
Consult with your dealer on this adjustment.

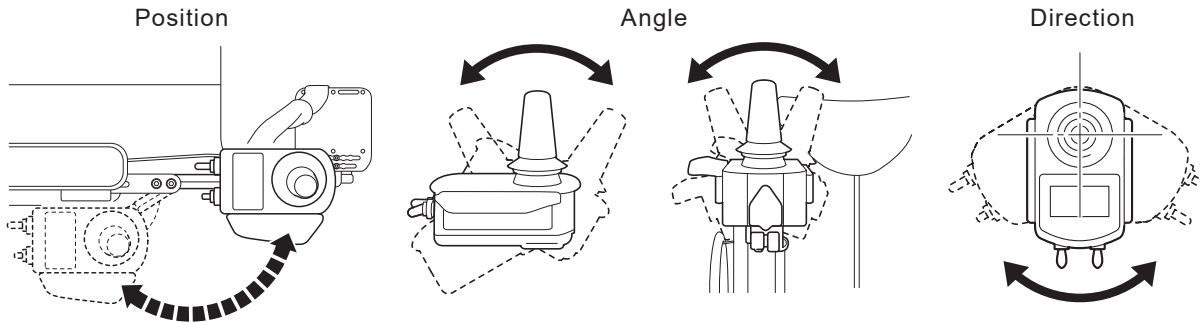

How to retract the controller

- (1) Turn off the power switch.

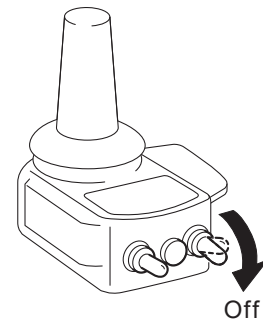

- (2) Turn the controller while the lock lever of the holder is pushed forward.

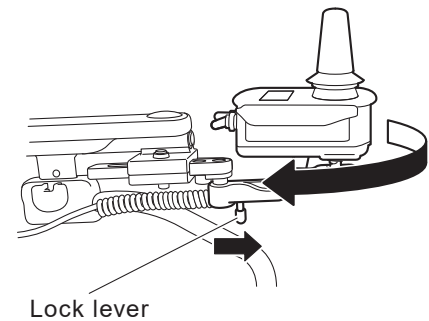

- (3) To return the controller to its original position, reverse the procedure.  
Make sure that the controller is locked in position.

## 11.4. Assistant Controller (Optional)

The mounting angle of the assistant controller can be adjusted.  
Consult with your dealer on this adjustment.

3-step adjustment

You can adjust the angle in the direction of the arrow.

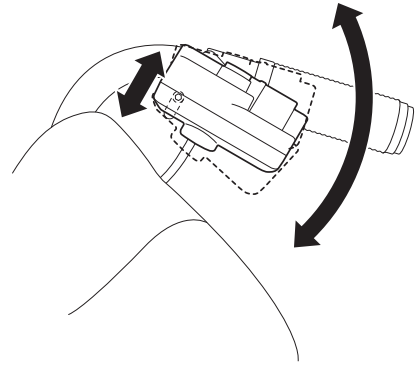

## 11.5. Clutch Levers

The mounting angle of the clutch levers can be adjusted.  
Consult with your dealer on this adjustment.

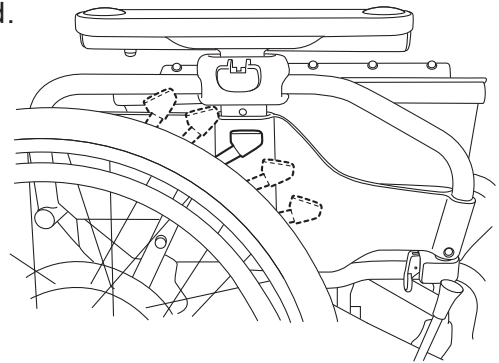

## 11.6. Parameter Settings

The settings of the features and characteristics of the iXpress can be changed to fit your usage. These changes are performed by changing the “parameter settings”. Consult with your dealer on changing the parameter settings.

There are two parameter settings: “Functional Parameters” and “Driving Parameters”.

### (1) Functional Parameters

#### ① Auto power off function

This is a function that turns off the power after a specified time of non-operation.

Setting 1 ..... The power turns off if the joystick has not been operated for 10 minutes.

(Default setting)

Setting 2 ..... The power turns off if the joystick has not been operated for 60 minutes.

Setting 3 ..... The power does not turn off automatically.

② Buzzer sound

This function is for sounding a buzzer when the power is turned on, or when an error such as disengaged clutches occurs.

Setting 1 ..... The buzzer sound is enabled. (Default setting)

Setting 2 ..... The buzzer does not sound when the power is turned on, the maximum speed is adjusted, the controller is operated with the clutch levers in the manual position, etc.

It is impossible to disable the horn and alert sounds.

③ LCD brightness

This function sets the brightness of the LCD of the controller.

Setting 1 ..... Normal brightness setting (Default setting)

Setting 2 ..... Slightly darker setting

Setting 3 ..... Dark setting

④ Electromagnetic brake operation timing selection

This function adjusts the time until the electromagnetic brake is applied after the wheelchair stops.

Setting 1 ..... The electromagnetic brake is applied 10 seconds after the wheelchair stops. (Default setting)

Setting 2 ..... The electromagnetic brake is applied immediately after the wheelchair stops.

(2) Driving Parameters

You can adjust settings such as speed, acceleration, and joystick sensitivity.

① Preset mode

Select from 3 preset modes.

Setting 1 ..... Soft mode

Setting 2 ..... Normal mode (Default setting)

Setting 3 ..... Sports mode

② Free mode

You can make fine adjustments to settings, such as speed, acceleration, joystick sensitivity, and joystick input direction switching.

 **WARNING**

- **When evaluating the need to change parameter settings and choosing the actual changes, consult the guidance of experts, such as physical therapists and occupational therapists, and have your dealer make the changes.**

## 11.7. Smart Tune Settings

The settings of the features and characteristics of iXpress can be changed to fit your use. These changes are performed by changing the “parameter settings” with using PC and the Smart Tune software. Consult with your dealer on changing the parameter settings. There are two parameter settings: “Functional Parameters” and “Driving Parameters”.

### (1) Functional Parameters

#### ① Auto power off function

This is a function that turns off the power after a specified time of non-operation.

Setting 1 ..... The power turns off if the joystick has not been operated for 10 minutes.  
(Default setting)

Setting 2 ..... The power turns off if the joystick has not been operated for 60 minutes.

Setting 3 ..... The power does not turn off automatically.

#### ② Buzzer sound

This function is for sounding a buzzer when the power is turned on, or when an error such as disengaged clutches occurs.

Setting 1 ..... The buzzer sound is enabled (Default setting)

Setting 2 ..... The buzzer does not sound when the power is turned, maximum speed is adjusted, when operated with the clutch levers in manual position, etc.

It is impossible to disable the horn and alert sounds.

#### ③ LCD brightness

This function sets the brightness of the LCD of the controller.

Setting 1 ..... Normal brightness setting (Default setting)

Setting 2 ..... Slightly darker setting

Setting 3 ..... Dark setting

#### ④ Electromagnetic brake operation timing selection

This function adjusts the time until the electromagnetic brake is applied after the wheelchair stops.

Setting 1 ..... The electromagnetic brake is applied 10 seconds after the wheelchair stops. (Default setting)

Setting 2 ..... The electromagnetic brake is applied immediately after the wheelchair stops.

(2) Driving Parameters

You can adjust settings such as speed, acceleration, and joystick sensitivity.

① Preset mode

Select from 3 preset modes.

Setting 1 ..... Soft mode

Setting 2 ..... Normal mode (Default setting)

Setting 3 ..... Sports mode

② Free mode

You can fine-adjust such settings as the speed, acceleration, motor torque.



**WARNING**

- **When evaluating the need to change parameter settings, and choosing the actual changes, consult the guidance of experts such as physical therapists and occupational therapists at the dealer.**

# 12. Maintenance, Daily Check, Periodic Inspection

It is recommended that the iXpress be inspected periodically at the dealer. (Inspection is fee-based)

To ensure long-term durability, we recommend that you perform regular inspections every 6 months after initial use.

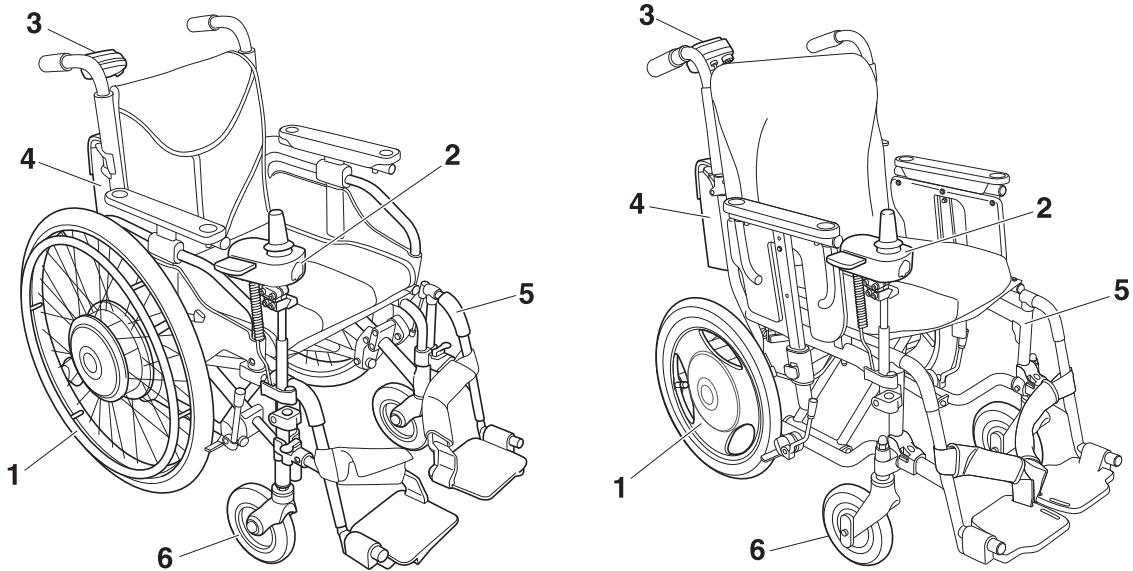

## Sample Inspection Form

Inspection Item		Date of Inspection	Inspection Area	Checked	Corrective Measure
1	Unit		Noise, jammed object		
			Tire air pressure (24" model: 450 kPa, 4.5 kg/cm <sup>2</sup> , 16" model: 350 kPa, 3.5 kg/cm <sup>2</sup> ), wear, cracks, loose valve, cap		
			Hand rim looseness, damage, harmful damage, burrs, sharp points, and so on		
			Spoke looseness, breakage		
			Torque stop tightening		
			Dust cover installation		
			Anti-tip device looseness, deformation, damage		
			Dirty terminals on battery seat		
			Clutch operation, clutch cable damage		
			Wire connection looseness, damage		
2	Controller		Damage, deformation, looseness, harmful damage, burrs, sharp points, and so on		
			Power switch, speed selector switch operation		
			Rubber cap damage		
			Joystick operation, actually move the joystick and make sure that it operates correctly.		
			Wire routing, damage		
3	Assistant controller (optional)		Damage, looseness, harmful damage, burrs, sharp points, and so on		
			Power switch, speed adjustment dial operation		
			Rubber cap damage		
			Brake lever play, effectiveness, squeal		
			Brake cable, wire routing, damage		
	Actually operate the controller and make sure that it operates correctly.				



Inspection Item		Date of Inspection	Inspection Area	Checked	Corrective Measure
4	Battery bag		Fray, wear and tear, or damage		
			Fray, damage, or foreign material on the straps, belt, or the cable fasteners on the bag		
			Looseness or slack in the upper straps and lower belt		
			Pinched if the wheelchair is folded		
			Caught or touched by moving parts		
5	Frame (example) or (reference)		Deformation, damage, bolt looseness, harmful damage, burrs, sharp points, and so on		
			Folding function		
			Creaking sound		
			Footrest looseness		
			Parking brake effectiveness, wear		
6	Casters (example) or (reference)		Air pressure (for pneumatic tires)		
			Wear, cracks		
			Looseness, wobbles, noise		
			Twisted valve stem, cap (for pneumatic tires)		

 **WARNING**

- **Continuing to use the wheelchair with a problem in the wheelchair body or the wheels may cause damage to the wheelchair while traveling, and may result in a rollover or fall.**

## 12.1. Maintenance

### [Cleanup]

If the iXpress becomes dirty due to normal use, use a tightly wrung-out towel to wipe off any dirt. If the dirt is excessive, use a towel and neutral detergent to remove the dirt. After removing the dirt, be sure to wipe off any remaining detergent.

**NOTICE**

- **Do not wash by directly hosing it down with water or high-pressure cleaner. Also, do not wash using steam. The electronic devices can get damaged, which may lead to malfunction.**
- **Do not clean with solvent such as gasoline or paint thinner. This may damage the painting and plastic parts.**

### [Disinfectant]

When disinfecting iXpress, use an alcohol-based disinfectant suitable for your application. When using, follow the disinfectant manufacturer's instructions for exposure time, concentration, etc. Then soak a towel with disinfectant and wipe the product with the towel. After disinfection, soak the towel in clean water, squeeze it tightly, and wipe off any remaining alcohol with the towel.

## NOTICE

- If you notice any abnormalities such as discoloration, discontinue the use of the disinfectant.
- Do not heat, pressurize, depressurize, supply electricity, irradiate with electromagnetic waves, immerse in a liquid, or spray directly. The electronic devices can get damaged, which may lead to malfunction.



## WARNING

- Read the disinfectant manual carefully before using the disinfectant.

### [Easy repairs]

The rubber covers “a” at the centers of the wheels can be installed easily without tools. If the rubber covers are damaged or lost, contact the dealer for replacements. If you continue to use the iXpress when these parts are damaged or not installed, dust or water could enter the unit and cause it to malfunction.

When new parts are installed, ensure that they are installed securely and operate correctly before using the wheelchair.

To purchase a new battery, contact the dealer.

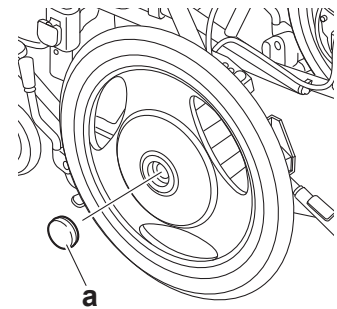

### [Normal repairs]

If other parts are damaged or lost, immediately contact the dealer. Have the dealer replace the parts or repair the wheelchair.

For normal maintenance, repairs, or service, be sure to contact the dealer. The user should not repair or service the wheelchair, or remove, pack, and send the parts to request repairs. If the wheelchair is not repaired or assembled completely, the user or those around the user could be injured.

To perform repairs and service, the dealer uses the service manual, parts catalog, and other documentation. These items are not sold to the general public.

When requesting repairs, do not send the wheelchair directly. First, contact the dealer.

In addition, a substitute wheelchair will not be provided during repairs or inspections.

You must pay for repairs that are not covered by the warranty.

### [Service life & Replacement parts]

The estimated service life is 6 years. However, the service life depends on the usage condition, environment and frequency. The service life means the period in which the product performance shall be maintained with performing the maintenance and inspection by the dealer. Parts that are necessary for repairs will be available for 8 years after the production has ended.

## 12.2. Daily Checks

Perform the following checks every day before operating the wheelchair. For details, refer to “3.1. Inspecting the Wheelchair”.

- |                   |   |
|-------------------|---|
| ① Exterior        | Visually check the components and ensure that they are not damaged.   |
| ② Anti-tip device | Make that the anti-tip device is in the correct position and locked in place.   |
| ③ Rear tires      | Make sure that there is tire depth, there are no cracks, and there is sufficient air pressure.<br>If the pressure is not enough, pump up to 450 kPa for iXpress 24" or 345 kPa for iXpress 16". |
| ④ Parking brakes  | Make sure that the parking brakes can stop the wheels from moving, and that they are installed securely to the frame.   |
| ⑤ Wheels          | Make sure that the wheels are not deformed and the spokes are not broken.   |
| ⑥ Casters         | Make sure that there is tire depth, and there are no cracks.<br>Make sure that the caster forks are not damaged.<br>Make that the nuts securing the tires are not loose.                        |
| ⑦ Battery         | Check the residual capacity.  |

If any problems are found, have the dealer repair the wheelchair.

## 12.3. End of JWX-1 PLUS Use Recycling

When the iXpress is at the end of its service life and must be disposed, contact your local government office first for recycling and follow their instructions. Or contact your dealer to recycle your used and its batteries.

### [About the European WEEE Directive 2012/19/eu]



The iXpress and its accessories are subject to the European WEEE Directive. Follow the applicable regulations of your country or region when discarding this instrument or its accessories. (WEEE stands for Waste Electrical and Electronic Equipment.)

# 13. Specifications

13

Model				Electric Power Unit for Wheelchairs		
				iXpress 24"		iXpress 16"
Weight	Total Weight (without assistant controller)	with battery	Nickel metal hydride battery	18 kg	17 kg	
			Lithium ion battery	18.4 kg	17.4 kg	
		without battery		15.0 kg	14 kg	
	Part weight			Right unit	7.5 kg	7 kg
				Left unit	6.5 kg	6 kg
				Controller	1 kg	
				Assistant controller	1 kg	
				Ni-MH battery	3 kg	
				Li-ion battery	3.4 kg	
Tire size				22"	24"	16"
Rear Tire	Tire specifications			37-501 (22x1 3/8)	37-540 (24x1 3/8)	47-305 (16x1/6/8)
	Recommended air pressure			450 kPa (65 PSI)	450 kPa (65 PSI)	345 kPa (50 PSI)
Drive motor				AC servomotor 24V 120W x 2 (30 minutes rated output)		
Drive system				Rear wheel direct drive		
Brake system				Motor generative brake + Electromagnetic brake		
Steering system				Joystick steering		
Control system				Microprocessor control		
Minimum Reversing Space width				Varies depending on the wheelchair the unit is installed on. Pivoting on a spot is possible. *1		
Maximum safe slope angle, rated slope				6 degree		
Maximum height of curbs that can be gone over				25 mm		
Maximum width of ditches that can be gone over				Varies depending on the wheelchair the unit is installed on and the caster size.		
Operating conditions	environment			Inside and outside		
	temperature			-25 to 50 °C *4		
	humidity			No condensation		
IEC waterproof standard				IPX4 (resistance against splashing water)		
Load capacity (including the rider, luggage, and frame weight)				125 kg *2		100 kg *2
Travel range	Continuous travel range (in accordance with Yamaha spec)	with Ni-MH battery (JWB2)		16 km *3		15 km *3
		with Li-ion battery (ESB1)		27 km *3		22 km *3
Travel speed	Controller (5-stge adjustment)	Forward		1.7–6.0 km/h		1.7–5.7 km/h
		Backward		1.0–3.0 km/h		0.9–2.8 km/h
	Assistant controller	Forward		1.4–5.0 km/h		
		Backward		0.5–2.0 km/h		

\*1 Minimum Reversing Space is the space required to pivot on a spot and is determined by the wheelchair frame.

Minimum Reversing Space Width

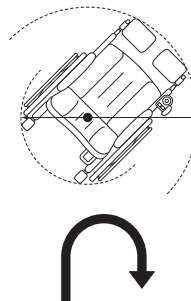

\*2 The value is the load capacity for the iXpress. When the wheelchair is completely assembled, the total weight of the rider and luggage must not exceed the load capacity of the wheelchair frame.

If the wheelchair is operated continuously with a load that exceeds this value, the product could malfunction or be damaged, or its life could be shortened.

\*3 The travel range varies depending on the conditions of the road surface (travel over curbs, on slopes, and so on) and may be shorter than this value.

\*4 This is the available temperature range. Confirm the recommended temperatures for "8.3." and "9.3."

Battery and Charger			Nickel-Metal Hydride	Lithium-ion
Battery	Model		JWB2	ESB1
	Type		Rechargeable Dry Battery with built in microprocessor	
	Nominal output voltage		24 V	25.2 V
	Rated output (5-hour rate)		6.7 Ah (160.8 Wh)	10.08 Ah (254 Wh)
Battery Charger (Ni-MH and Li-ion combined charger)	Model		ESC3	
	Charging method		Automatic Charging controlled by the microprocessor	
	Rated Input during charging		100 V–240 V, 50/60 Hz, 1.1A–0.5 A	
	Rated output during charging		29 V · 2.6 A	29.2 V · 3 A
	Chargeable battery		JWB2	ESB1
	Charging time	Time for normal charging	Approx. 3 hr	Approx. 4 hr
		Time for refresh charging	3–19 hr	—

# 14. Troubleshooting, Repairs, Warranty

If you have flat tires, contact your dealer. The tire structure of iXpress is same to the bicycle tires. Generally bicycle shops can repair the flat tires.







## 14.1. Before Requesting Repairs

Check the following troubleshooting tables.



### When Operating the Wheelchair

Problem	LCD Indication	Buzzer	Check Point	What to Do
The wheelchair does not start moving, or stops while traveling.		Beeps (Pi Pi) (4 times)	Are the clutch levers in the manual drive position?	Shift the clutch levers to the power drive position.
		Beeps (Pi —)	Has the battery run down?	Charge the battery. If there are no problems with the battery, contact your dealer.
			Do you use a lithium ion battery, and are you operating the wheelchair in a place where the ambient temperature is below the freezing point, or in the scorching heat of summer? Additionally, was the wheelchair stored in a place where the ambient temperature dropped below the freezing point, or where the temperature became hot, such as inside a car?	Switch to manual operation.
			Is the battery properly inserted?	Insert the battery properly.
			When operated by the rider, is the assistant controller turned on?	In this case, turn off the power switches on both controllers, and turn on the power for the controller.
			When operated by the assistant, is the controller turned on?	In this case, turn off the power switches on both controllers, and turn on the power for the assistant controller.
		Beeps (Pi —)	Are you turning on the power while the joystick is tilted?	Bring the joystick to the neutral position, turn off the power, and then turn it back on again. If the problem is not resolved, contact your dealer.
			Has the power been turned off automatically by the auto power off function?	Turn off the power, and then turn it back on again.
	Beeps (Pi —)	Has the motor overheated as a result of abusive riding?	Turn off the power. Wait a while before resuming the ride.	
Unable to operate			Are the brakes engaged on the wheelchair?	Release the brakes.
			Is the anti-tampering function turned on?	Turn off the anti-tampering function.
		Beeps (Pi —)	Are the controller and assistant controller operating?	Contact your dealer.

Problem	LCD Indication	Buzzer	Check Point	What to Do
Shortage of power		Beeps (Pi —) repeatedly	Is there a large load being applied?	It will stop beeping once the load is reduced.
	  	Beeps (Pi) repeatedly	Is there a large load being applied, causing the motor to overheat?	Lighten the load so that the motor will not overheat.
			Is the ambient temperature low? Is the battery stored in a place where the temperature becomes hot, such as inside a car?	The battery power decreases when the battery temperature is A or lower or B or higher. Wait until the battery reaches an appropriate temperature. A: Ni-MH= -5 °C (23 °F) Li-ion= 0 °C (32 °F) B: Ni-MH= NA Li-ion= 45 °C (113 °F)
			Has the battery deteriorated?	Replace with a new battery. For a nickel metal hydride battery, try refresh charging.
		Beeps (Pi Pi Pi Pi) (4 times)	Is the battery residual capacity sufficient?	Promptly move to a safe place, turn off power and charge the battery, or replace with a spare battery (sold separately).
Buzzer sounds continuously		Beeps (Pi Pi — Pi Pi —) repeatedly	Is the anti-tip device retracted?	Extend the anti-tip device.
Short travel range, or insufficient speed			Is the battery sufficiently charged?	Replace with a new battery. For a nickel metal hydride battery, try refresh charging.
			Is the ambient temperature low?	The battery power decreases when the temperature drops.
			Is the wheelchair carrying heavy loads or driving uphill?	Heavy loads tend to shorten the travel range.
			Is the speed parameter set to the standard setting?	Contact your dealer.
			Is the speed setting set to a low speed setting?	Adjust it to a higher speed setting.
Sluggish manual travel			Is the air pressure of the tires too low?	Inflate the tires.
			Are the brakes engaged on the wheelchair?	Release the brakes.
Assistant brakes do not work			Does the brake lever have too much play?	Contact your dealer.
Assistant brakes pull to one side			Are both brakes adjusted evenly?	Contact your dealer.
Brakes squeal			Are the brake drums damaged or are the brake shoes worn out?	Contact your dealer.
			Have the brakes been applied for a long time?	The brakes can make a noise depending on how they are applied, but this is not abnormal.
Abnormal vibration or noise			Is the area where the axle is mounted loose?	Tighten it or contact your dealer.
			Is there noise coming from the drive unit?	Contact your dealer.
			Is the wheelchair frame or front casters wobbling?	Contact your dealer.

## When Charging with ESC3 (Ni-MH Nickel Metal Hydride Battery)

Problem	Charger LED Indication	Battery LED Indication	Check Point	What to Do
Will not charge	Off	Off	Is the power cord connected?	Connect the power cord to a power source.
	Off	Off	Will another battery accept a charge?	If it can be charged, the charger is normal. Use a rechargeable battery. If it cannot be charged, the charger may be faulty. Contact your dealer.
	Flashing green (5 times per second)	Off		The charger has remained in standby mode for a long time and has stopped charging the battery. Wait for the battery temperature to drop and try to charge the battery again.
	Flashing red (5 times per second)	Off	Are a Ni-MH battery and a Li-ion battery connected at the same time?	If both are connected at the same time, disconnect one of them.
			Can another battery be charged?	If it can be charged, the charger is normal. Use a rechargeable battery. If it cannot be charged, the charger may be faulty. Contact your dealer.
	Flashing red (once per second)	Off		Unplug the power plug, stop charging the battery and contact your dealer.
Lit red	Off		Unplug the power plug, stop charging the battery and contact your dealer.	
Prolonged charge standby	Flashing green (once per second)	Residual capacity indicator lamps are lit	Is the battery temperature appropriate?	The charger is in standby mode. This does not indicate a malfunction. Wait until the battery reaches an appropriate temperature.
		Residual capacity indicator lamps are lit	Is the ambient temperature appropriate?	Charge the battery in an environment with an appropriate temperature.
Stops charging halfway	Off	Residual capacity indicator lamps are lighted only halfway	Is the temperature of the battery high?	After the battery has cooled down, try charging again.
Takes too long to charge	Lit orange	Residual capacity indicator lamps are lit, and then turned off successively	Are you refresh charging the battery?	The battery is being discharged. Refresh charging will take 3 to 19 hours.
After charging is completed, all of the lamps are not lit	Off	Residual capacity indicator lamps are lighted only halfway	Check the number of times or days you have used the battery.	Has the battery deteriorated? After approximately 300 charge/discharge cycles, the battery capacity will decrease to approximately 60% of that of a new battery.
The charger emits a sound	Lamp display varies with the conditions.	Residual capacity indicator lamps are lit	Is the sound unusual?	Unplug the power plug, stop charging the battery and contact your dealer.
The charger gets unusually hot	Lamp display varies with the conditions	Residual capacity indicator lamps are lit	While the charger is charging the battery, it is normal for the unit to heat up to some degree (about 104–140 °F, about 40–60 °C). If the charger gets too hot, though, it may be malfunctioning.	Unplug the power plug, stop charging the battery and contact your dealer.
The charger emits an odor	Lamp display varies with the conditions	Residual capacity indicator lamps are lit	Does this occur immediately after you start using the charger?	The charger may emit an odor immediately after it is put to use, but the odor will disappear eventually. If the odor persists, unplug the power plug, stop charging the battery and contact your dealer.



## When Charging with ESC3 (Li-ion 22 Lithium Ion Battery)

Problem	Charger LED Indication	Battery LED Indication	Check Point	What to Do
Will not charge	Off	Off	Is the power cord connected?	Connect the power cord to a power source.
	Off	Off	Will another battery accept a charge?	If it can be charged, the charger is normal. Use a rechargeable battery. If it cannot be charged, the charger may be faulty. Contact your dealer.
	Flashing green (5 times per second)	Off		The charger has remained in standby mode for a long time and has stopped charging the battery. Wait for the battery temperature to drop and try to charge the battery again.
	Flashing red (5 times per second)	Off	Are a Ni-MH battery and a Li-ion battery connected at the same time?	If both are connected at the same time, disconnect one of them.
			Can another battery be charged?	If it can be charged, the charger is normal. Use a rechargeable battery. If it cannot be charged, the charger may be faulty. Contact your dealer.
	Flashing red (once per second)	Off		Unplug the power plug, stop charging the battery and contact your dealer.
Lit red	Off		Unplug the power plug, stop charging the battery and contact your dealer.	
Prolonged charge standby	Flashing green (once per second)	Residual capacity indicator lamps are lit	Is the battery temperature appropriate?	The charger is in standby mode. This does not indicate a malfunction. Wait until the battery reaches an appropriate temperature.
	Flashing green (once per second)	Residual capacity indicator lamps are lit	Is the ambient temperature appropriate?	Charge the battery in an environment with an appropriate temperature (cool in the summer and warm in the winter).
Stops charging halfway	Off	Residual capacity indicator lamps are lighted only halfway	Is the temperature of the battery high?	After the battery has cooled down, try charging again.
After charging is completed, all of the lamps are not lit	Off	Residual capacity indicator lamps are lighted only halfway	Check the number of times or days you have used the battery.	Has the battery deteriorated? After approximately 300 charge/discharge cycles, the battery capacity will decrease to approximately 60% of that of a new battery.
The charger emits a sound	Lamp display varies with the conditions.	Residual capacity indicator lamps are lit	Is the sound unusual?	Unplug the power plug, stop charging the battery and contact your dealer.
The charger gets unusually hot	Lamp display varies with the conditions	Residual capacity indicator lamps are lit	While the charger is charging the battery, it is normal for the unit to heat up to some degree (about 104–140 °F, about 40–60 °C). If the charger gets too hot, though, it may be malfunctioning.	Unplug the power plug, stop charging the battery and contact your dealer.
The charger emits an odor	Lamp display varies with the conditions	Residual capacity indicator lamps are lit	Does this occur immediately after you start using the charger?	The charger may emit an odor immediately after it is put to use, but the odor will disappear eventually. If the odor persists, unplug the power plug, stop charging the battery and contact your dealer.

## 14.2. Requesting Repairs and Inspections

For your inspection, repair, and service needs, contact the dealer from which you purchased iXpress. When contacting the dealer, your product serial number may be required. Refer to below to check the serial number, and provide it to the dealer.

Sales dealer:

## 14.3. Serial Number Location

The serial number is shown on the bottom of the battery seat.

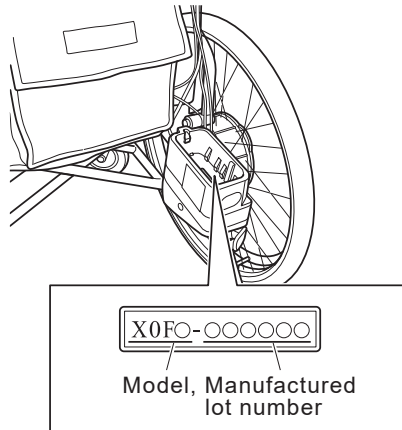

## 14.4. Warranty

The warranty period for the iXpress is 1 year from the date of purchase.

During this warranty period, if there is a material or manufacturing defect in the iXpress that you have purchased, the defective parts will be replaced or repaired free of charge. The warranty covers the power unit, controller, assistant controller, and charger. Consumable parts, such as the battery, tires, and tubes, are excluded from this warranty.

This warranty does not cover malfunctions due to either the user's intentional misuse or negligent use, such as malfunctions that are caused by use other than that specified in this owner's manual. This warranty also does not cover malfunctions due to modification of the unit or continuous use under conditions other than the specified conditions, such as exceeding the maximum weight etc., regardless of the cause of the malfunction.

Scratches, dullness, and dirt on the surface of the product through normal use are not included in the warranty.

If warranty repairs are necessary, contact the dealer where you purchased the unit.

### **Additional warranty information for Australia only.**

1. For goods distributed by Sunrise Medical Pty Ltd in Australia, our goods come with a guarantee by Sunrise Medical (on behalf of the manufacturer) that cannot be excluded under Australian Consumer Law.
2. You are entitled to a replacement or refund for a major failure and for compensation for any other reasonably foreseeable loss or damage.
3. You are also entitled to have the goods repaired or replaced if the goods fail to be of acceptable quality and the failure does not amount to a major failure.
4. The benefits to you given by this warranty are in addition to your other rights and remedies under a law in relation to the goods to which the warranty relates.

A large, stylized black graphic element above the word "QUICKIE", resembling a thick, curved line that loops back on itself.

# QUICKIE®