

Jay® J2 Back

Owner's Manual

JAY®

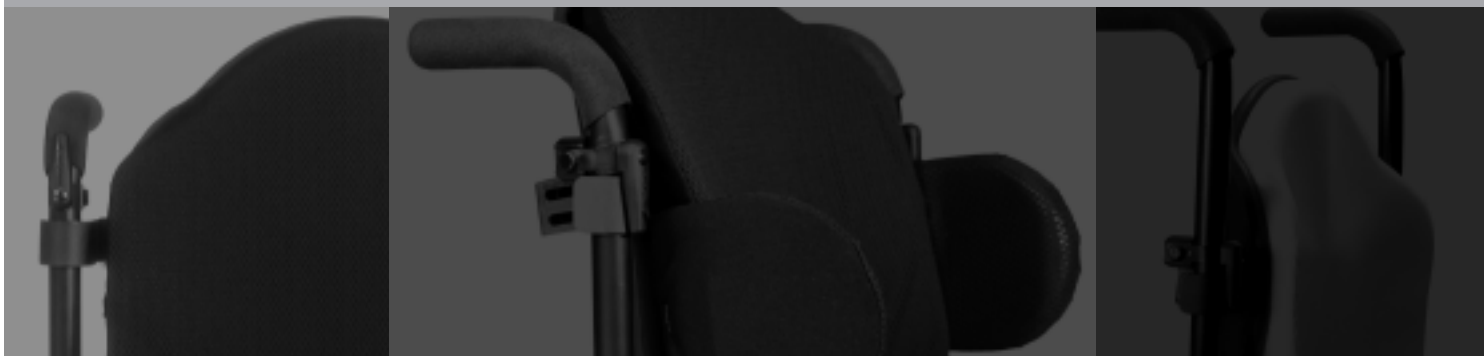

Improving People's Lives

Sunrise Medical recommends that a clinician such as a doctor or therapist experienced in seating and positioning be consulted to determine if a J2 Back is appropriate. Backs should only be installed by an authorized Sunrise Medical supplier.

Maximum user weight: 250 lbs. (113 kg).

CAUTION

Installing a back support on a wheelchair may affect the center of gravity of the wheelchair and may cause the wheelchair to tip backwards potentially resulting in injury.

Always assess for the potential need for anti-tippers or amputee axle adapter brackets to be added to the wheelchair to help increase stability.

EASY CLEANING AND REASSEMBLY FOR JAY® J2 BACK - 2500 SERIES MODELS

To clean back cover

Pull foam insert away from back shell. Unzip cover. Remove foam and turn cover inside out. Zip cover closed to avoid snagging. If applicable, note where lumbar shims are placed to ensure proper re-assembly. Machine wash in warm water. Dry in dryer on medium heat.

NOTE: Do not dry clean covers or use industrial washers and dryers to clean cover. Do not steam autoclave. Do not bleach.

Replace foam in cover and zip closed. The “Top” label on the cover should be at the top, rear of the foam. Ensure that the cover fits properly by aligning the seams with the edge of the foam.

Replace lumbar shims if applicable. Place foam insert on shell. Ensure that “Top” label on cover is at the top of the Back shell. Press into the Back shell, matching the Velcro® strips on the cover with the Velcro strips on the shell.

To clean back shell

Shell may be wiped clean with soap and water. No other maintenance should be required.

MAINTENANCE AND TORQUE SPECIFICATIONS

Sunrise recommends that all fasteners be checked for wear, such as loose bolts or broken components every 6 months. Loose fasteners should be retightened according to the installation instructions. All fasteners should be tightened to 2.3 N-m (20 in-lbs). Contact your authorized Sunrise Medical supplier immediately to replace any broken components. Do not continue to use the system after identifying loose or broken components.

DETERMINING COMPATIBILITY

Wheelchair Types

The J2 Back is designed to be compatible with most wheelchairs with the following exceptions:

Wheelchairs that are angularly adjustable, recline or tilt and result in a back angle greater than 60 degrees from the vertical should not be used.

WARNING

Use with these types of wheelchairs may cause the back to accidentally disconnect from the wheelchair resulting in a fall and the potential for serious injury.

The J2 Back has not been tested for use as seating in a motor vehicle. As a result the performance of the back in combination with wheelchairs that are labeled for transit use when used as a seat in a motor vehicle is unknown. Sunrise Medical recommends that users not occupy a wheelchair in a motor vehicle when using the J2 Back.

WARNING

Using a J2 Back as seating in a motor vehicle may cause the back to accidentally disconnect from the wheelchair resulting in a fall and the potential for serious injury.

Wheelchair Dimensions

The J2 Back is designed to replace the wheelchair’s sling upholstery. The mounting hardware system is designed for tubular back canes. Prior to installation determine if the wheelchair used has compatible back canes. Start by checking the table below to see if the back canes are a correct width.

Back Model Number	Width of back canes from center to center of the tubes (Fig. I-A)			
	Minimum width		Maximum width	
	inch	cm	inch	cm
2512K	10.3	32.2	11.5	35.4
2513K	11.3	33.2	12.5	36.4
2514K, 2514TK	12.3	34.2	13.5	37.4
2515K, 2515TK	13.3	35.2	14.5	38.4
2516K, 2516TK	14.3	36.2	15.5	39.4
2517K, 2517TK	15.3	37.2	16.5	40.4
2518K, 2518TK	16.3	38.2	17.5	41.4
2519K, 2519TK	17.3	39.2	18.5	42.4
2520K, 2520TK	18.3	40.2	19.5	43.4

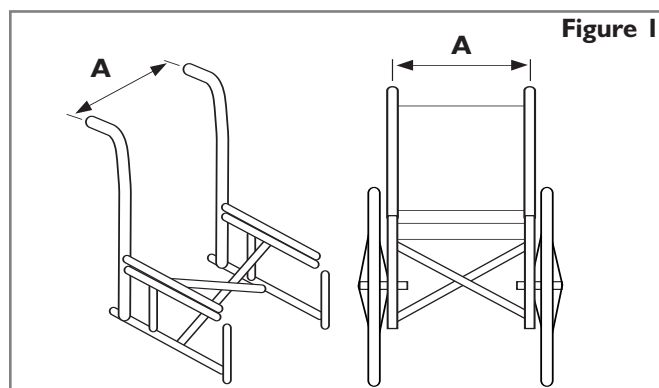
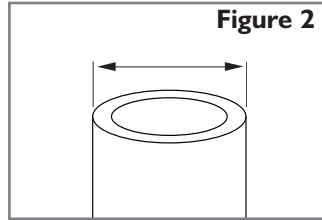

Figure I

Next check that the back canes are a compatible diameter. The strap style back mounting hardware may be used on back canes from 0.62 to 1.1 inches (16mm to 28mm) in diameter. (Fig. 2)



If you cannot determine that the back canes are compatible please contact your authorized Sunrise Medical provider or Sunrise Medical customer service.

FITTING THE J2 BACK

The J2 Back is designed to replace the wheelchair's sling upholstery. The initial installation should be done without the foam insert in the back shell. Tighten all fasteners to 20 in.-lbs. (2.3 N-m) using a Phillips No. 2 screwdriver.

1. Remove the upholstery from the back of the wheelchair.
2. Attach one bottom post bracket to each upright post of the wheelchair.
 - a. Check the diagram for the proper holes for different wheelchair post diameters. (The bracket comes assembled to attach to 7/8"-1" (2.2cm -2.5cm) posts. To attach 5/8"-3/4" (1.6cm-1.9cm) posts remove caps and insert screws into both inside holes.) Wrap the band around the wheelchair post. Screw "A" may have to be loosened to align strap hole with barrel nut. Place a washer on the screw and insert through the proper hole.
 - b. Insert screw "B" into the side of the bracket and tighten firmly to 2.3 N-m (20 in.-lbs). Ensure that the screw engages the insert inside the bracket.
 - c. Place caps over both screw heads.
 - d. To adjust the height of the bracket, loosen screw "A" until bracket slides freely on wheelchair post. Once proper height of the back is determined, tighten screw "A" to 2.3 N-m (20 in.-lbs). All future adjustments of the back height are done with this screw.

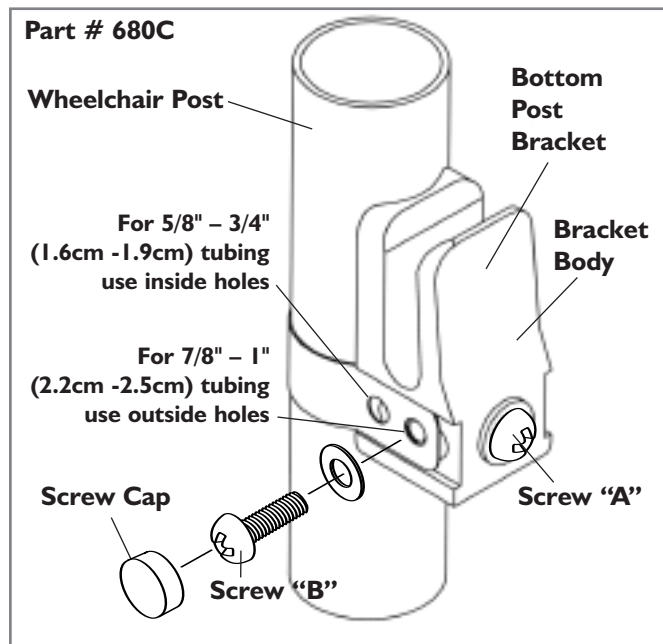

3. Install the J2 Back.

Place the J2 Back in the wheelchair so that the bottom pins on the back shell slide into the bottom post brackets and the top of the back rests against the uprights. The top hooks (on the upper portion of the back shell) should rest flush against the posts.

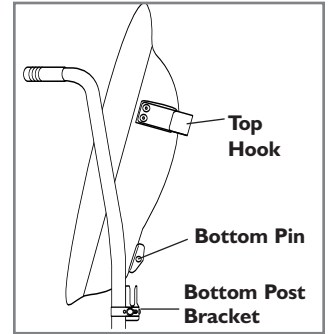

4. Bottom width adjustment.

Remove the J2 Back from the wheelchair. Lift tab on bottom brackets with a screwdriver tip and slide the pins to adjust width to match wheelchair post width. Check to ensure the pins extend to the full width of the bottom post brackets. Count the number of holes exposed to ensure the back is adjusted evenly on both sides.

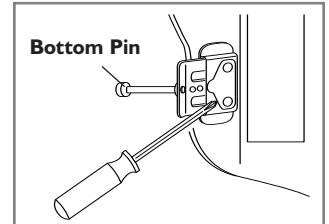

5. Top width adjustment.

Depress the silver pin on top brackets with a screwdriver tip and slide top bracket to adjust width to match wheelchair post width. Ensure that the back is adjusted evenly on both sides. Replace back in wheelchair.

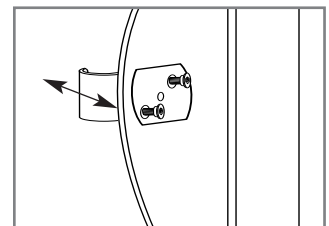

6. Assess and adjust back height.

Replace the foam insert. Assess client for back height. Position the user's hips to the back of the wheelchair. The center of the bottom pin on the J2 Back should be placed at approximately the level of the PSIS or S1-S2 spinal level of the individual. (The PSIS is the top, rear of the pelvis.) This will help maintain a stable pelvis when the back angle is adjusted. To adjust the height of the back, loosen screw "A" and slide post brackets up or down. Once proper height is determined, tighten brackets firmly to 2.3 N-m (20 in.-lbs).

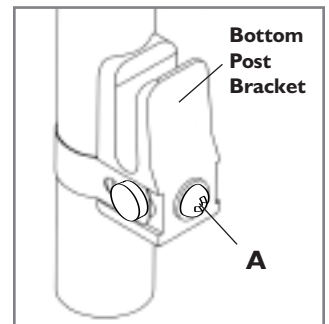

INSTALLING THE TOP QUICK-RELEASE QUARTER TURN BRACKET HARDWARE

1. Attach one top quick-release quarter turn bracket to each upright post of the wheelchair.
 - a. The top quick-release quarter turn bracket is designed to fit on 5/8", 3/4", 7/8" and 1" (1.6, 1.9, 2.2 and 2.5 cm) diameter back post tubing. (The bracket comes assembled to attach to 7/8" or 1" (2.2 or 2.5cm) tubing) Check diagram 1 to determine which strap hole is appropriate for the installation. Wrap the strap around the wheelchair post. Screw "A" may have to be loosened to align the strap hole with the barrel nut located inside the bracket body. Place a washer on screw "B" and insert the screw through the appropriate hole in the strap.
 - b. Tighten screw "B" (to 2.3 N-m (20 in-lbs)) into the barrel nut through the side of the bracket body. Tighten the opposite screw if necessary.
 - c. Snap the screw caps over both screw heads.
 - d. To adjust the height of the bracket, loosen screw "A" until the bracket slides freely on the back post. Once the proper height of the back is determined, tighten the screw firmly to 2.3 N-m (20 in-lbs). All future adjustments of the back height are done with screw "A".
 - e. Always turn the quick-release quarter turn bracket to the "DOWN" position (diagram 2) to secure the top hook in place.

CAUTION– The top quick-release quarter turn brackets must be in their downward position when the back is in use. Improper use may cause the back to unexpectedly detach from the wheelchair.

CAUTION– Do not use J2 Back to push or lift wheelchair. Improper use may cause the back to unexpectedly detach from the wheelchair.

NOTE– The back is properly secured when the bottom pins are resting in the lower post brackets and the upper quick-release quarter turn brackets are installed above the back support's top hook brackets with the quick-release mechanism pointing down.

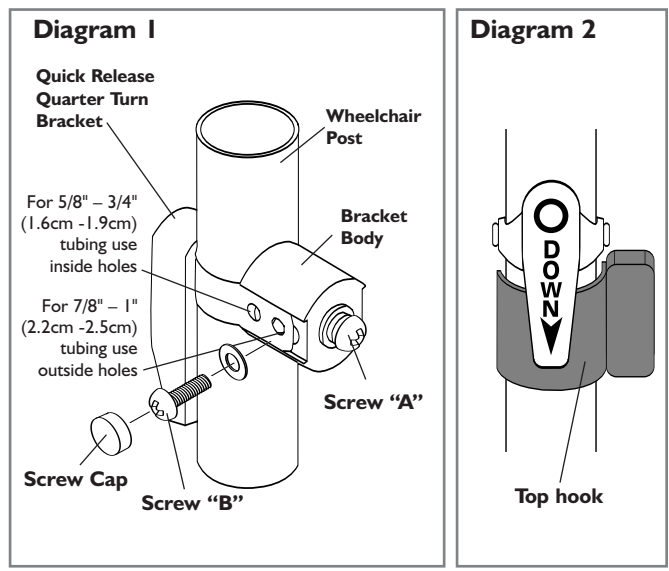

8. Assess and adjust back angle.

Assess client for back angle. To recline, turn screw "C" on the back of the top bracket at the rear of the back. Turning the screw clockwise will make the back more vertical. Turning the screw counter clockwise will recline the back. Check the hash marks on both sides of top brackets to ensure that the back is evenly adjusted.

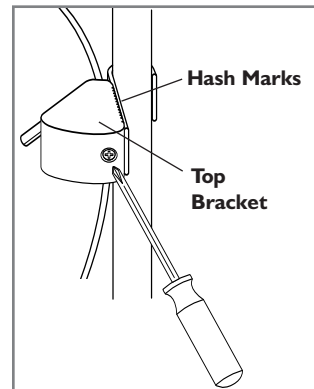

9. Add lumbar/pelvic shim(s) as required.

Remove foam insert and unzip the back cover. Insert the lumbar/pelvic shim(s) inside the cover behind the large piece of foam where needed. Zip the cover closed and place the foam insert back in the shell.

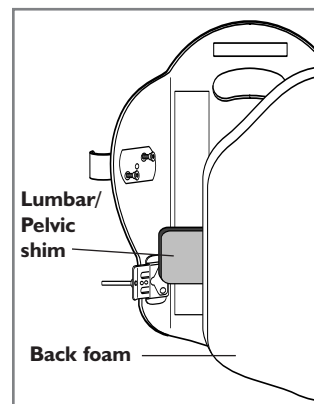

REMOVAL AND REPLACEMENT

Following installation and adjustment, the back can be easily removed from the wheelchair if necessary. Simply twist the quick release brackets out of the way on both sides and lift the back up and out of the chair. To replace, lower the bottom pins into the lower post brackets and rock the back backward until it rests against the upright posts. Twist the quick-release brackets down over the top hooks on the back. The back will not lose angle adjustment when removed and replaced on the wheelchair.

Proper reattachment after removal

Check to make sure the pin attached to the backrest is resting completely at the bottom of the slotted receptacle attached to the wheelchair back cane.



Check to make sure that the quarter fastener attached to the wheelchair back cane is turned downward in its locked position.

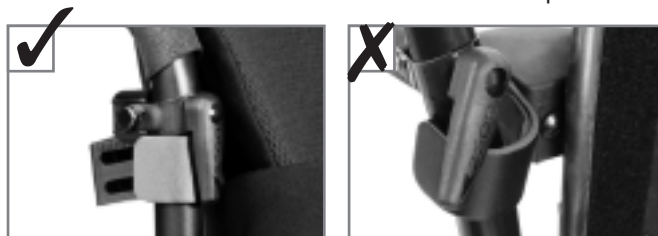

24 MONTH LIMITED WARRANTY

Each J2 back is carefully inspected and tested to provide peak performance. Every J2 back is guaranteed to be free from defects in materials and workmanship for a period of 24 months from the date of purchase, provided normal use. Should a defect in materials or workmanship occur within 24 months from the original date of purchase, Sunrise Medical will, at its option, repair or replace it without charge. This warranty does not apply to punctures, tears or burns, nor to the back's removable cover.

Claims and repairs should be processed through the nearest authorized supplier. Except for express warranties made herein, all other warranties, including implied warranties of merchantability and warranties of fitness for a particular purpose are excluded. There are not warranties which extend beyond the description on the face hereof. Remedies for breach of express warranties herein are limited to repair or replacement of the goods. In no event shall damages for breach of any warranty include any consequential damages or exceed the cost of non-conforming goods sold.

Sunrise Medical Australia Pty Ltd
11 Daniel Street Wetherill Park
Phone: (02) 9678 6600
Email: enquiries@sunrisemedical.com.au
www.sunrisemedical.com.au



©2006 Sunrise Medical Inc. 9.06
XT2505 Rev. J