



QS5 X

Directions for Use

QUICKIE®

www.sunrisemedical.com

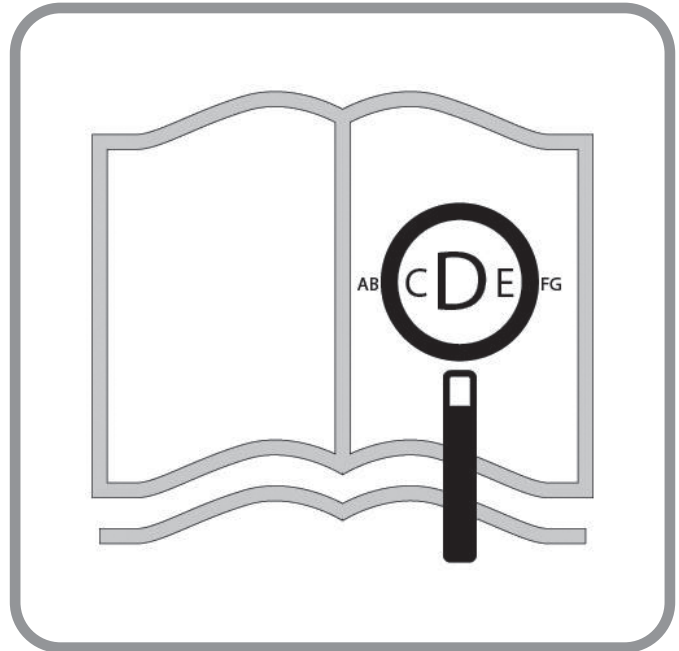
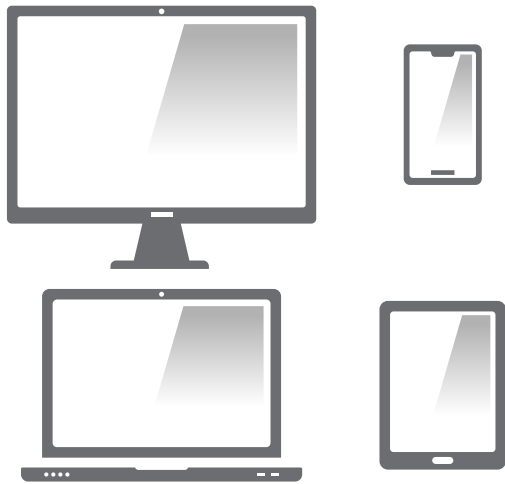

If you are visually impaired, this document can be viewed in pdf format at www.Sunrisemedical.co.uk or alternatively is available on request in large text.

Wheelchair Components

EN



We at SUNRISE MEDICAL have been awarded the ISO-13485 certificate, which affirms the quality of our products at every stage, from R & D to production. This product complies with the standards set forth in EU and UK regulations. Options or accessories shown are available at extra cost.

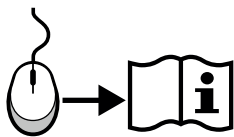

EN 07

Wheelchairs:



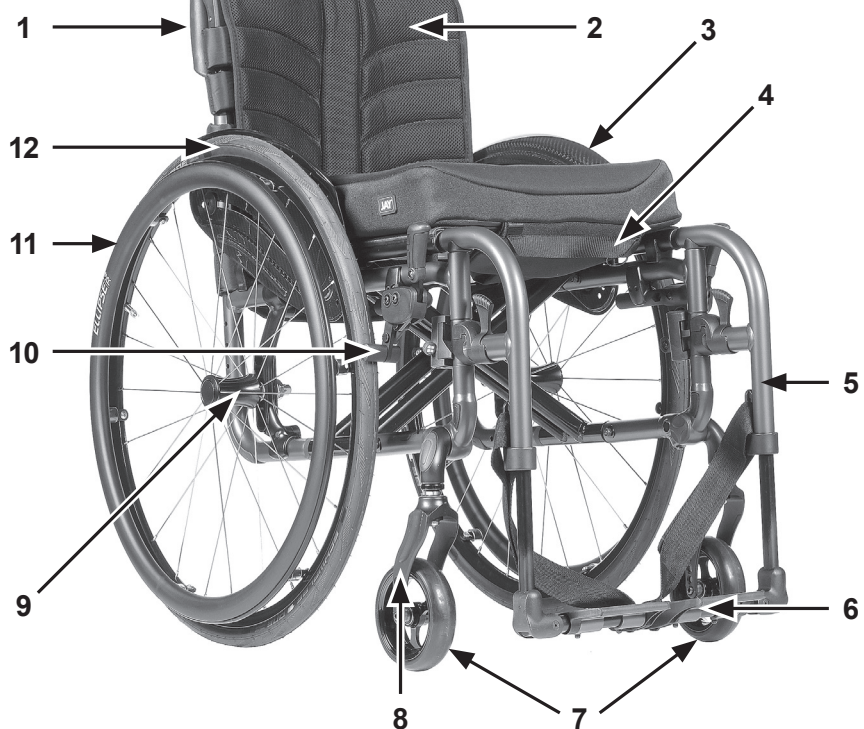

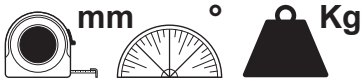





1. Push handles
2. Backrest upholstery
3. Sideguard
4. Seat sling
5. Footrest
6. Footboard
7. Castors
8. Fork
9. Quick-release axle
10. Wheel locks
11. Handrim
12. Rear wheel





	1113 ↕ 750		840 ↕ 515		1020 ↕ 700		500 ↕ 340
	540 ↕ 360		500 ↕ 340		320 ↕ 230		655 ↕ 545
	500 ↕ 250		540 ↕ 340		320 ↕ ...		
	1512 ↕ 1106		360 ↕ 250		75 ↕ 25		MAX. (mm) ↕ MIN. (mm)
	10° ↕ 10°		10° ↕ 10°		10° ↕ 10°		< MAX. (°) ↕ < MIN. (°)
	19° ↕ ...		105° ↕ 80°		110° ↕ 90°		< MAX. (°) ↕ < MIN. (°)
	15.5 ↕ 7.5		18.0 ↕ 10.1		140 ↕ ...	 2.2 Kg Heaviest part of the chair	< MAX. (Kg.) ↕ < MIN. (Kg.)

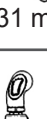
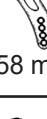

					
 105 mm	3	420			
	2	430	440		
	1	440	450		
	1 + Spacer	450	460		
 115 mm	3	430			
	2	440	450		
	1	450	460		
	1 + Spacer	460	470		
 115 mm + Hemi	3	360			
	2	370	380		
	1	380		410	
	1 + Spacer	390		420	
 131 mm	4		440/450		
	3	440/450	460	470	
	2	460	470	480	
	1	470	480	490	
	1 + Spacer	480	490	500	
 158 mm	4		470	480	490
	3	470	480	490/500	500/510
	2	480	490/500	510	520
	1	490	510	520	530
	1 + Spacer	500	520	530	540
 158 mm + Hemi	4		400		
	3	400	410	430	
	2	410	430	440	
	1	430	440	450	
	1 + Spacer	440	450		

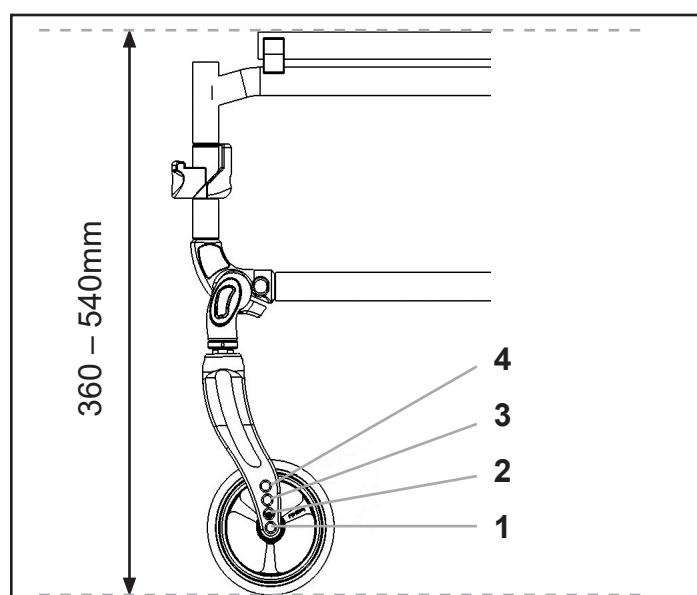

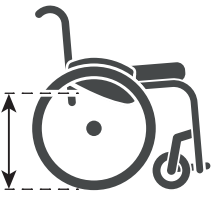
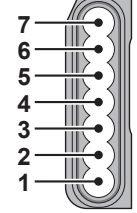
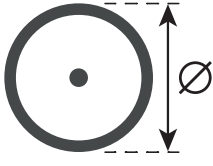
		
350	turned 7	22
360	turned 6	22
370	turned 5	22
380/390	turned 4	22
400	7	22
410	6	22
420	5	22
430/440	4	22
450	3	22
460	2	22
470/480	1	22

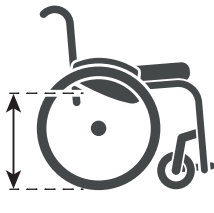
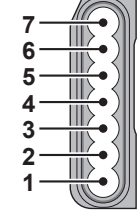
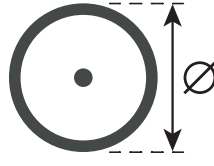
		
370	turned 7	24
380/390	turned 6	24
400	turned 5	24
410	turned 4	24
420	7	24
430/440	6	24
450	5	24
460	4	24
470	3	24
480/490	2	24
500	1	24

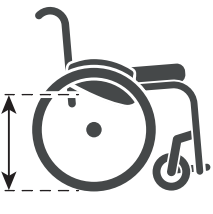
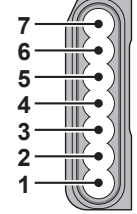
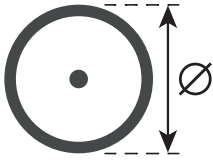
		
430	7	25
440	6	25
450/460	5	25
470	4	25
480	3	25
490/500	2	25
510	1	25

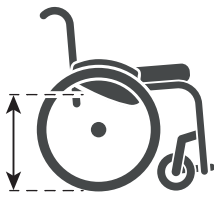
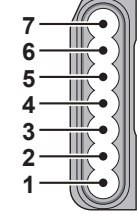
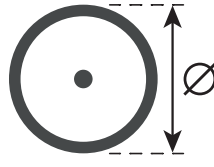
		
450	7	26
460	6	26
470	5	26
480/490	4	26
500	3	26
510	2	26
520/530	1	26

NOTE: Wherever torque settings are specified, it is strongly recommended that a torque meter (not included), is used to verify correct torque specification is achieved. If no other information is given, the generic torque for M6 screws is 7 Nm.

⚠ DANGER: Some of the screws that are used during manufacture are fitted with threadlock, (blue dot on the thread) and can be undone and re-tightened up to three times before they must be replaced with new screws and threadlock. Alternatively, you can put Loctite™ 243 threadlock on the screws and re-fit them.

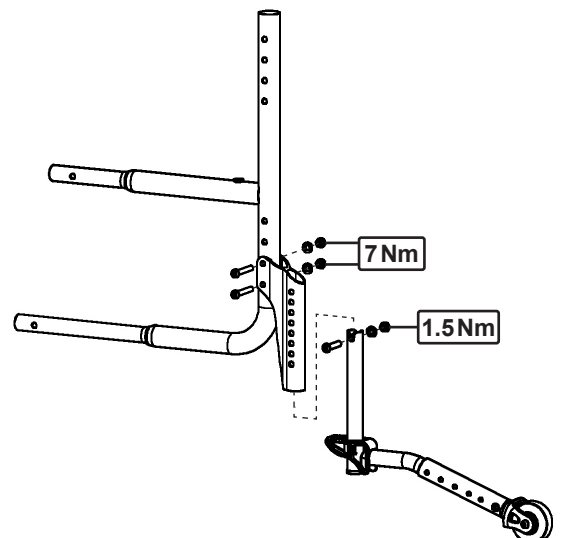
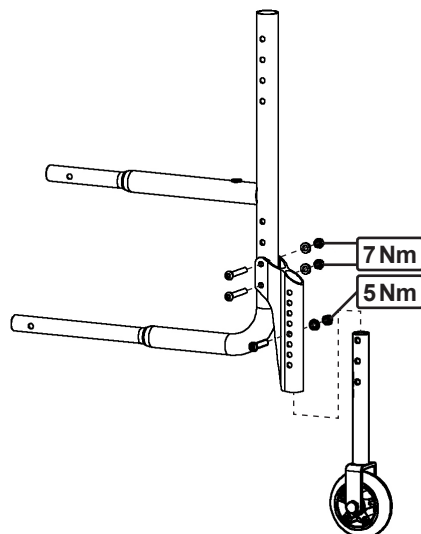
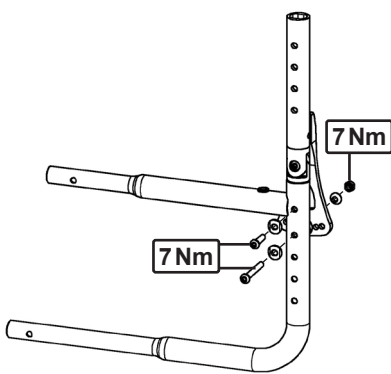
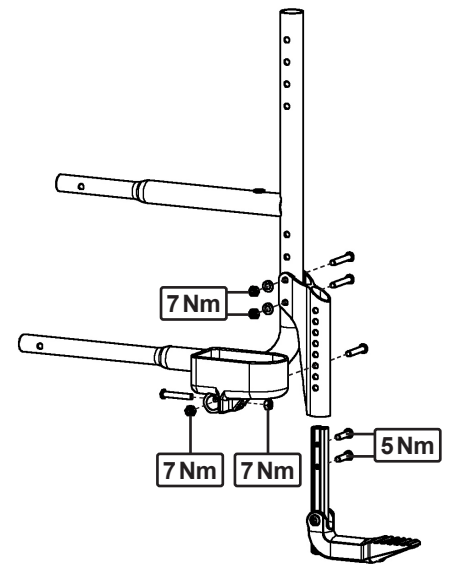
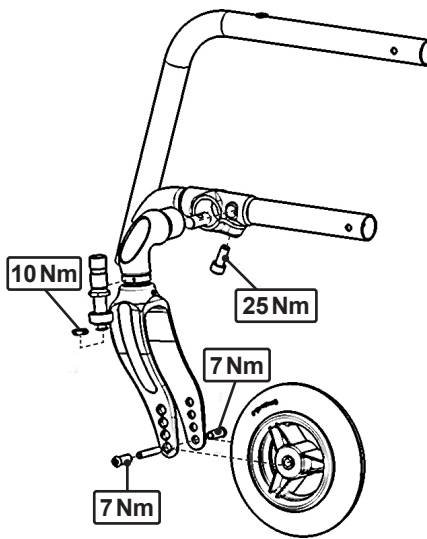
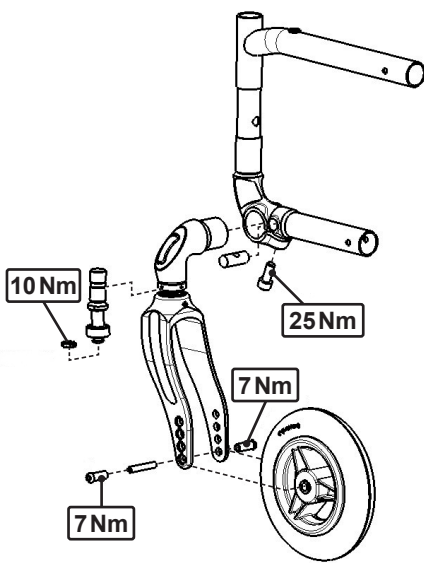
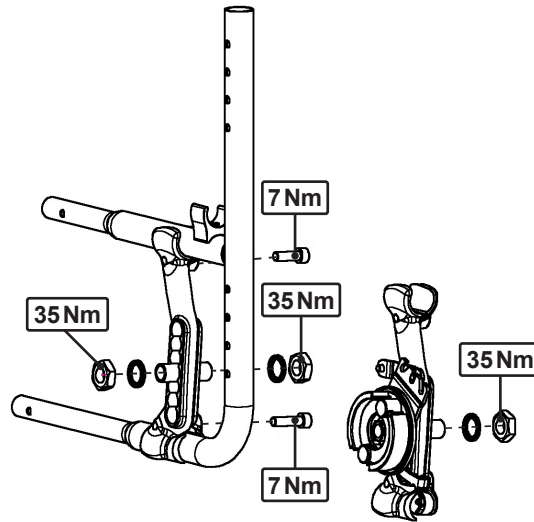

Table of Contents

Definitions	7
Foreword	8
Use	9
Area of application	9
1.0 General safety notes and driving limits	10
2.0 Warranty	13
3.0 Transportability	14
4.0 Handling	17
5.0 Transporting the Wheelchair	18
6.0 Options	19
6.1 Brakes	19
6.2 Step Tubes	21
6.3 Footrests	21
6.4 Castor	24
6.5 Adjustment of the Centre of Gravity (CoG)	25
6.6 Backrest	26
6.7 Half Folding Back	28
6.8 Stabilising bar	28
6.9 Headrests	29
6.10 Options – Hemiplegic armrest	29
6.11 Sideguards	29
6.12 Options – One Hand Operation	32
6.13 Tray	32
6.14 Push Handles	32
6.15 Push handle	33
6.16 Anti-tip tubes	33
6.17 Crutch holder	33
6.18 LED Light	34
6.19 Pelvic Restraint Belt	35
6.20 Transit wheels	36
7.0 Tyres and Mounting	36
8.0 Name Plate	37
9.0 Maintenance and care	38
10.0 Trouble shooting	39
11.0 Disposal / recycling of materials	39
12.0 Technical Specifications	40







NOTE:

The wheelchairs shown and described in this user guide may not correspond in every detail exactly to your own model. However, all instructions are completely relevant, regardless of possible detail differences.

The manufacturer reserves the right to alter without notice any weights, measurements or other technical data shown in this manual. All figures, measurements and capacities shown in this manual are approximate, and do not constitute specifications.

Definitions

3.1 Definitions of words used in this manual

Word	Definition
 DANGER!	Advice to the user of Potential Risk of serious injury or death if the advice is not followed
 WARNING!	Advice to the user of a potential risk of injury if the advice is not followed
 CAUTION!	Advice to user that potential damage to equipment may occur if the advice is not followed
NOTE:	General advice or best practice
	Reference To Additional Documentation
	Solid
	Soft tyres
	Does not fit

NOTE:

Please keep a note of your local service agent's address and telephone number in the space provided. In the event of a breakdown, contact them and try to give all relevant details so they can help you quickly.

Dealer signature and stamp

Foreword

Dear Customer,

We are very pleased that you have decided in favour of a high-quality SUNRISE MEDICAL product.

This Owner's manual will provide numerous tips and ideas so that your new wheelchair can become a trustworthy and reliable partner in your life.

For Sunrise Medical, it is very important that we have a good relationship with our customers. We like to keep you up-to-date about new and current developments at our company. Keeping close to our customers means: fast service, as little red tape as possible, working closely with customers. When you need replacement parts or accessories, or if you just have a question about your wheelchair – we are there for you.

We want you to be satisfied with our products and service. At Sunrise Medical we are constantly working to develop our products further. For this reason, changes can occur in our palette of products with regard to form, technology, and equipment. Consequently, no claims can be construed from the data or pictures contained in this Owner's manual.

The management system of SUNRISE MEDICAL is certified to ISO 13485 and ISO 14001.

 As the manufacturer, SUNRISE MEDICAL, declares that this product conforms to the Medical Device Regulation (2017/745).

 As the manufacturer, SUNRISE MEDICAL, declares that the product conforms to the UK Medical Devices Regulation 2002 No. 618.

NOTE:

General user advice.

Not following these instructions may result in physical injury, damage to the product or damage to the environment!

Notice to the user and/or patient: Any serious incident that has occurred in relation to the device should be reported to the manufacturer and the competent authority of the Member State in which the user and/or patient is established.

B4Me special adaptations

Sunrise Medical strongly recommends that in order to ensure that your B4Me product operates, and performs as intended by the manufacturer; all the user information supplied with your B4Me product is read and understood, before the product is first used.

Sunrise Medical also recommends that the user information is not discarded after reading it, but it is kept safely stored for future reference.

Medical Device Combinations

It may be possible to combine this Medical device with one or more other Medical Device or other product. Information on which combinations are possible can be found at www.SunriseMedical.co.uk. All combinations listed have been validated to meet the General Safety and Performance Requirements, Annex I Nr. 14.1 of the Medical Device Regulation 2017/745.

Guidance on the combination, such as mounting, can be found at www.SunriseMedical.co.uk

Please contact your local, authorised SUNRISE MEDICAL dealer if you have any questions regarding the use, maintenance or safety of your wheelchair.

In case there is no authorised dealer in your area, or you have any questions about product safety and product recalls, contact Sunrise Medical either in writing or by telephone or find the information on www.SunriseMedical.co.uk.

Sunrise Medical

Thorns Road
Brierley Hill
West Midlands
DY5 2LD

Phone: 0845 605 66 88

Fax: 0845 605 66 89

www.SunriseMedical.co.uk



IMPORTANT:

DO NOT USE YOUR WHEELCHAIR UNTIL THIS MANUAL HAS BEEN READ AND UNDERSTOOD.

Use

Wheelchairs are exclusively for children and adults who are unable to walk or have limited mobility, for their own personal use, when self-propelling and being moved by a third party (pushed by attendant), within the home and outdoors.

The maximum weight limit (includes the user and any weight of accessories fitted to the wheelchair) is marked on the serial number label, which is affixed to the crossbar or stabiliser bar below the seat.

Warranty can only be taken on if the product is used under the specified conditions and for the intended purposes.

The expected life of the wheelchair is 5 years.

Please DO NOT use or fit any 3rd party components to the wheelchair unless they are officially approved by Sunrise Medical.

DANGER!

- Do not fit any unauthorized electronic equipment.
- Do not fit powered or mechanically operated mobility devices, drives, hand-bike or any other device that changes the intended use or the structure of the wheelchair.
- Any combination with other medical devices requires approval directly from Sunrise Medical.

Area of application

Indication:

The variety of fitting variants as well as the modular design mean that it can be used by those who cannot walk or have limited mobility e.g. because of:

- Paralysis
- Loss of extremity (leg amputation)
- Extremity defect deformity
- Joint contractures/joint injuries
- Illnesses such as heart and circulation deficiencies, disturbance of equilibrium or cachexia as well as for elderly people who still have the strength in the upper body. When considering provision, please also note the body size, weight, physical and psychological constitution, the age of the person, living conditions and environment

Contraindication:

- Perception disorder
- Imbalance
- Loss of both arms
- Joint contracture or joint damage on both arms
- Seating disability

Please note that driving a wheelchair requires sufficient cognitive, physical and visual skills. The user must be able to assess the effects of actions during the operation of the wheelchair and, if necessary, to correct them. These capabilities and the safe use of the additionally attached components cannot be assessed by Sunrise Medical as a manufacturer. We cannot accept any liability for any damage resulting from this.

Please refer to the operating instructions of the wheelchair and the additionally mounted components. Instruct the user in the safe use of the wheelchair and the additionally mounted components. Inform users of specific warnings that need to be read, understood, and respected.

When considering provision, please also note the body size, weight, physical and psychological constitution, the age of the person, living conditions and environment.

Operating Conditions

The wheelchair can be used indoors as well as outdoors in self-propelled or attendant configurations, on dry, firm, relatively smooth surfaces. It is not recommended for use in a storm, torrential rain, snow and ice or other extreme weather conditions.

1.0 General safety notes and driving limits

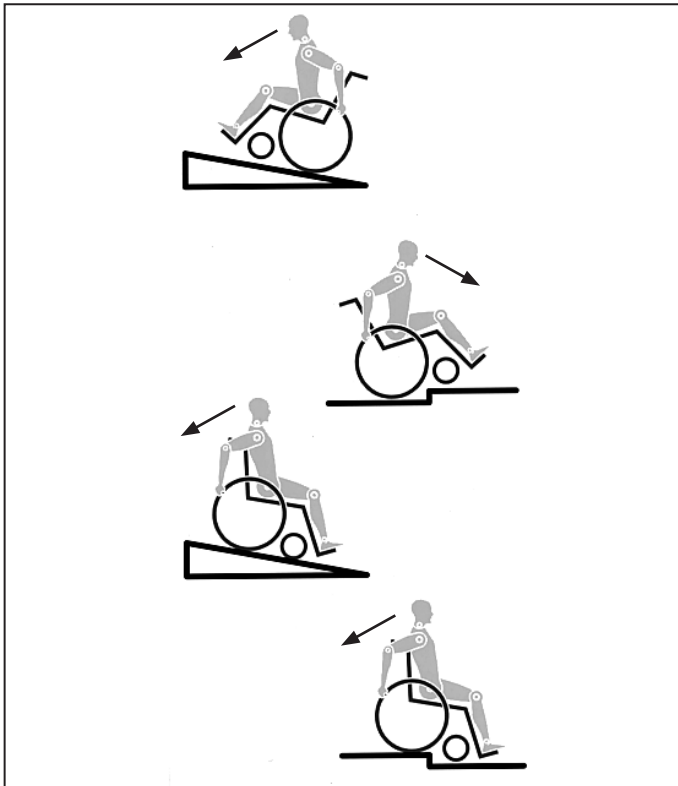

The engineering and construction of this wheelchair has been designed to provide maximum safety. International safety standards currently in force have either been fulfilled or exceeded in parts. Nevertheless, users may put themselves at risk by improperly using their wheelchairs. For your own safety, the following rules must be strictly observed.

Unprofessional or erroneous changes or adjustments increase the risk of accident. As a wheelchair user, you are also part of the daily traffic on streets and pavements, just like anyone else. We would like to remind you that you are therefore also subject to any and all traffic laws. Be careful during your first ride in this wheelchair. Get to know your wheelchair.

Before each use, the following should be checked:

- Quick-release axles on the rear wheels
- Velcro on seats and backrests
- Tyres, tyre pressure and wheel locks.

Before changing any of the adjustments of this wheelchair, it is important to read the corresponding section of the user's manual.

It is possible that potholes or uneven ground could cause this wheelchair to tip over, especially when riding uphill or downhill. When riding forwards over a step or up an incline, the body should be leaning forward.

DANGER!

- NEVER exceed the maximum load of 140 kg (136 kg crash tested), for driver plus any items carried on the wheelchair. Please note the weight information for lighter weight options, which are quoted separately. If you exceed the maximum load, this can lead to damage to the chair, or you may fall or tip over, lose control and may lead to serious injury of the user and other people.
- When it is dark, please wear light clothing or clothing with reflectors, so that you can be seen more easily. Make sure that the reflectors on the side and back of the wheelchair are clearly visible. We would also recommend that you fit an active light.
- To avoid falls and dangerous situations, you should first practice using your new wheelchair on level ground with good visibility.
- When getting on or off the wheelchair, do not use the footboards. These should be flipped up beforehand and swung to the outside as far as possible. Always position yourself as close as possible to the place where you wish to sit.
- Only use your wheelchair properly. For example, avoid travelling against an obstacle without braking (step, kerb edge) or dropping down gaps.
- The wheel locks are not intended to brake your wheelchair. They are only there to ensure that your wheelchair does not begin rolling unintentionally. When you stop on uneven ground, you should always use the wheel locks to prevent such rolling. Always apply both wheel locks; otherwise, your wheelchair could tip over.
- Explore the effects of changing the centre of gravity on the behaviour of the wheelchair, for example on inclines, slopes, all gradients or when overcoming obstacles. Do this with the secure aid of a helper.
- With extreme settings (e.g. rear wheels in the most forward position) and less than perfect posture, the wheelchair may tip over even on a level surface.
- Lean your upper body further forward when going up slopes and steps.
- Lean your upper body further back when going down slopes and steps. Never try to climb and descend a slope diagonally.
- Do not use an escalator. This may lead to serious injury in the event of a fall.

- Do not use the wheelchair on slopes > 10°. The Dynamic safe slope is dependent on the chair configuration, the user's abilities and the style of riding. As the user's abilities and style of riding cannot be pre-determined then the max safe slope cannot be determined. Therefore this must be determined by the user with the assistance of an attendant to prevent tipping. It is strongly recommended that inexperienced users have anti-tip tubes fitted.
- It is possible that potholes or uneven ground could cause this wheelchair to tip over, especially when riding uphill or downhill.
- Do not use your wheelchair on muddy or icy ground. Do not use your wheelchair where pedestrians are not allowed.
- To avoid hand injuries do not grab in between the spokes or between the rear wheel and wheel lock when driving the wheelchair.
- In particular when using lightweight metal handrims, fingers will easily become hot when braking from a high speed or on long inclines.
- Riding sideways on to a slope or incline, increases the possibility of the wheelchair tipping over sideways.
- Only attempt stairs with the help of an attendant. There is equipment available to help you, e.g. climbing ramps or lifts, please use them. If there is no such equipment available, then the wheelchair must be tipped and pushed, never carried, over the steps (2 helpers). We recommend that users over 100 kg in weight do not use this stairway manoeuvre!
- In general, any anti-tip tubes fitted must be set beforehand, so that they cannot touch the steps, as otherwise this could lead to a serious tumble. Afterwards the anti-tip tubes must be set back to their correct position.
- Make sure that the attendant only holds the wheelchair using securely mounted parts (e.g. not on the footrests or the sideguards).
- This wheelchair is not designed to be used whilst weight training and/or when using dumbbells. Only use equipment specifically designed for this purpose.
- Do not lift or carry the wheelchair by the backtubes or the pushhandles.
- When using the lifting ramp make sure that the anti-tip tubes fitted are positioned outside the danger area.
- Secure your wheelchair on uneven ground or when transferring, e.g. into a car, by using the wheel-locks. Make sure the wheel locks are properly locked and can't be accidentally opened while transfer i.e. by asking an attendant to hold the wheel-lock levers.
- If and whenever possible, during a journey in a specially fitted vehicle for disabled people, vehicle occupants should use the seats in the vehicle and the appropriate restraint system. This is the only way to ensure that occupants will have the maximum protection if there is an accident. When using safety elements offered by SUNRISE MEDICAL and using a specially designed safety system, lightweight wheelchairs can be used as a seat when being transported in a specially fitted vehicle. (See the Chapter on "Transportation").
- Depending on the diameter and setting of the castors, as well as the centre of gravity setting of the wheelchair, the castors may begin to wobble at high speeds. This can lead to the castors being blocked and the wheelchair may tip over. Therefore, please make sure that the castors are adjusted correctly (see the Chapter "Castors"). In particular, do not travel on an incline without brakes, travel at a reduced speed. We recommend that novice users use anti-tip tubes.
- Anti-tip tubes should prevent the chair tipping over backwards unintentionally. Under no circumstances should they take the place of transit wheels, and be used to transport a person in a wheelchair with the rear wheels removed.
- When reaching for objects (which are in front of, to the side or behind the wheelchair) make sure that you do not lean too far out of the wheelchair, as if you change the centre of gravity there is a risk of tipping or rolling over. The hanging of additional load (back pack or similar items) onto your chair backposts can affect the rearward stability of your chair, especially when used in combination with recliner backrests. This can cause the chair to tip backwards causing injury.
- Adjustments to your wheelchair, particularly to safety-related components must be carried out by an approved dealer. This applies to adjustments to wheel locks, anti-tip tubes, backrest angle and height, lower leg length, COG, lap belt, rear wheel toe-in and camber, seat height as well as toe-in and directional stability of the castor fork.
- When using mobility accessories fitted to the wheelchair such as handbikes, electronic power assist, etc, make sure that your wheelchair is fitted with the appropriate castor forks, approved for this use. Please contact your dealer if you have any questions.
- Do not fit any unauthorized electronic equipment, powered or mechanically operated mobility drives, hand-bike or any other device that changes the intended use or the structure of the wheelchair.
- Any combination with other medical devices requires the approval of Sunrise Medical.
- Please note that in certain configurations the wheelchair may exceed a width of 700 mm. If this is the case, under certain circumstances, it may not be possible to use some or all of the available escape routes from a building. It may be more difficult or impossible to travel on public transport.
- Further information and safety instructions can be provided by your authorised dealer.
- For thigh amputees you must use anti-tip tubes.
- Your wheelchair can be carrying current, so be careful when interacting with electrical sources.
- For persons being allergic to latex, we recommend to use solid tyres as there's a risk of latex contamination for pneumatic tyres and inner tubes.

- Before setting off, check that your tyre pressure is correct. For rear wheels it should be at least 3.5 bar (350 kPa). The max. pressure is indicated on the tyre. The knee-lever brakes will only work if there is sufficient tyre pressure and if the correct setting has been made (see the Chapter on “Brakes”).
- If the seat and back sling are damaged, you must replace them immediately.
- Be careful with fire, in particular with burning cigarettes. Seat and back slings can be set alight.
- If the wheelchair is subject to direct sunlight for a long period of time, then parts of the wheelchair (e.g. frame, legrests, brakes and sideguard) may become hot (>41°C).
- Always make sure that the quick-release axles on the rear wheels are set properly and lock in. If the button on the quick-release axle is not pressed in, the rear wheel cannot be removed.

 **WARNING!**

- The effect of the knee-lever brake as well as the general driving characteristics are dependent on tyre pressure. The wheelchair is significantly lighter and easier to manoeuvre when the rear wheels are pumped up correctly and both wheels have the same pressure.
- Make sure that your tyres have sufficient tread! Please note that you are subject to any and all traffic laws when driving in public traffic.
- Always be careful with your fingers when working or adjusting the wheelchair!

 **WARNING!**

CHOKING HAZARD – This mobility aid uses small parts which under certain circumstances may present a choking hazard to small children.

The wheelchairs shown and described in this user guide may not correspond in every detail exactly to your own model. However, all instructions are completely relevant, regardless of possible detail differences.

The manufacturer reserves the right to alter without notice any weights, measurements or other technical data shown in this manual. All figures, measurements and capacities shown in this manual are approximate and do not constitute specifications.

Sunrise Medical is ISO 13485 certified, which ensures quality at all stages of the development and production of our products. This product complies with the standards set forth in EU and UK directives. Optional equipment and accessories are available at extra charge.

2.0 Warranty

THIS GUARANTEE DOES NOT AFFECT YOUR LEGAL RIGHTS IN ANY WAY.

Sunrise Medical* provides a guarantee, as set out in the warranty conditions, for wheelchairs to its customers covering the following.

Warranty conditions:

1. Should a part or parts of the wheelchair require repair or replacement as a result of a manufacturing and/or material fault within 24 months or for frame and cross-braces within 5 years after delivery to the customer, then the affected part or parts will be repaired or replaced free of charge. The warranty will only cover manufacturing defects
2. To enforce the warranty, please contact Sunrise Medical Customer Service with the exact details of the nature of the difficulty. Should you be using the wheelchair outside the area covered by the Sunrise Medical customer service agent, repairs or replacement will be carried out by another agency as designated by the manufacturer. The wheelchair must be repaired by a Sunrise Medical designated Customer Service agent, (dealer).
3. For parts, which have been repaired or exchanged within the scope of this warranty, we provide a warranty in accordance with these warranty conditions for the remaining warranty period for the wheelchair in accordance with point 1).
4. For original spare parts which have been fitted at the customer's expense, these will have a 12 months guarantee, (following the fitting), in accordance with these warranty conditions.
5. Claims from this warranty shall not arise, if a repair or replacement of a wheelchair or a part is required for the following reasons:
 - a. Normal wear and tear, which include batteries, armrest pads, upholstery, tyres, brakes shoes, etc.
 - b. Any overloading of the product, please check the EC label for maximum user weight.
 - c. The product or part has not been maintained or serviced in accordance with the manufacturer's recommendations as shown in the user instructions and/or the service instructions.
 - d. Accessories have been used which are not specified as original accessories.
 - e. The wheelchair or part having been damaged by neglect, accident or improper use.
 - f. Changes/modifications have been made to the wheelchair or parts, which deviate from the manufacturer's specifications.
 - g. Repairs have been carried out, before our Customer Service has been informed of the circumstances.
6. This guarantee is subject to the law of the country in which the product was purchased from Sunrise Medical*

* Means the Sunrise Medical facility from which the product was purchased.

Additional Notes For Australia Only:

- i. For goods provided by Sunrise medical Pty Ltd in Australia, our goods come with a guarantee by Sunrise Medical that cannot be excluded under Australian Consumer Law.
- ii. You are entitled to a replacement or refund for a major failure and for compensation for any foreseeable loss or damage.
- iii. You are also entitled to have the goods repaired or replaced if the goods fail to be of acceptable quality and the failure does not amount to a major failure.
- iv. The benefits to you given by this warranty are in addition to your other rights and remedies under a law in relation to the goods to which the warranty relates.

3.0 Transportability

DANGER!

There is a risk of serious injury or death if this advice is ignored!

Transportation of your wheelchair within a vehicle:

A wheelchair secured in a vehicle will not provide the equivalent level of safety and security as a vehicle seating system. It is always recommended that the user transfers to the vehicle seating. It is recognised that this is not always practical for the user to be transferred and in these circumstances, where the user must be transported whilst in the wheelchair, the following advice must be followed:

1. Confirm that the vehicle is suitably equipped to transport a passenger in a wheelchair, and ensure the method of access/egress is suitable for your wheelchair type. The vehicle should have the floor strength to take the combined weight of the user, the wheel chair and accessories.
2. Sufficient space should be available around the wheelchair to enable clear access to attach, tighten and release the wheelchair and occupant tie down restraints and safety belts.
3. The occupied wheelchair must be located in a forward facing position and secured by the wheelchair tie down and occupant restraint straps (WTORS tie downs meeting the requirements of ISO 10542 or SAE J2249) in accordance with the WTORS manufacturer's instructions.
4. The wheelchair's use in other positions within a vehicle has not been tested e.g. transportation in a side facing position must not be carried out under any circumstances (Fig. A).
5. The wheelchair should be secured by a Tie Down Restraint system, conforming to ISO 10542 or SAE J2249 with non-adjustable front straps and adjustable rear straps, which typically use Karabiner clips/S hooks and tongue and buckle fittings. These restraints generally comprise of 4 individual straps that are attached to each corner of the wheelchair.
6. The tie-down restraints should be fitted to the main frame of the wheelchair as indicated in the diagram on page 16 (Figs. G & H), and not to any attachments or accessories, e.g. not around the spokes of wheels, brakes or footrests.
7. The tie-down restraints should be attached as close as possible at an angle of 45 degrees and tightened securely in accordance with the manufacturer's instructions.
8. Alterations or substitutions must not be made to the wheelchair securement points or to structural and frame or components without consulting the manufacturer. Failure to do so will invalidate the ability of a Sunrise Medical wheelchair to be transported within a vehicle.
9. Both pelvic and upper torso restraint belts must be used to restrain the occupant to reduce the possibility of head and chest impacts with the vehicle components and serious risk of injury to the user and other vehicle occupants. (Fig. B) The upper torso restraint belt should be mounted to the vehicle "B" pillar - failure to do so will increase the risk of serious abdominal injuries to the user.
10. A head restraint suitable for transportation (see label on headrest) must be fitted and suitably positioned at all times during transportation.
11. Postural supports (lap straps, lap belts) should not be used or relied on for occupant restraint in a moving vehicle unless they are labelled as meeting the requirements specified in ISO 7176-19 or SAE J2249.
12. The safety of the user during transportation depends upon the diligence of the person securing the tie-down restraints and they should have received appropriate instructions and/or training in their use.
13. If the wheelchair has been involved in an accident, discontinue use immediately and contact the Authorized Dealer for a thorough inspection.

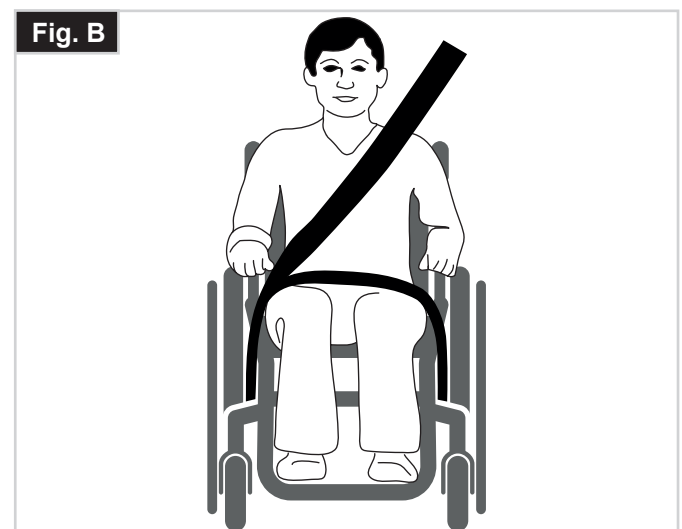
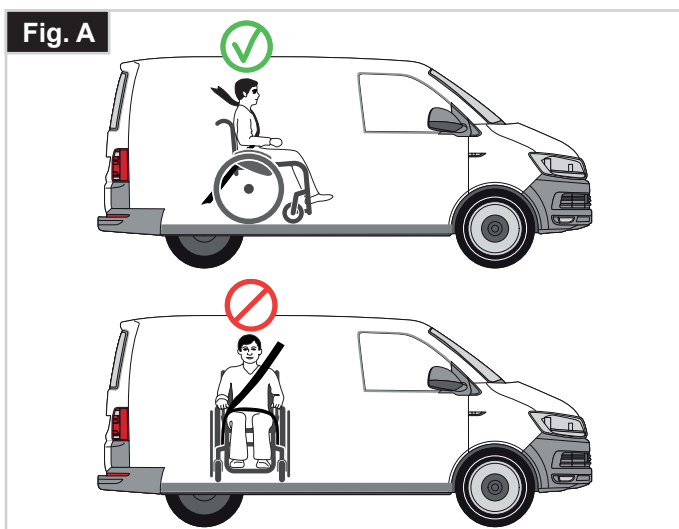

Transportability (continued)

14. Wherever possible remove and stow safely away from the wheelchair all auxiliary equipment, for example: Crutches, Loose cushions and Tray Tables.
15. Articulating/elevating leg rest should not be used in the elevated position when the wheelchair and user are being transported and the wheelchair is restrained using Wheelchair Transport and Occupant Restraints.
16. Reclining backrests should be returned to an upright position.
17. The manual brakes must be firmly applied.
18. Restraints should be mounted to the vehicle "B" pillar and should not be held away from the body by wheelchair components such as armrest or wheels.

Occupant Restraints Instruction:

1. The pelvic restraint belt must be worn low across the front of the pelvis so that the angle of the pelvic belt is within the preferred zone of 30 to 75 degrees to the horizontal.

A steeper (greater) angle within the preferred zone is desirable i.e. closer to, but never exceeding 75 degrees. (Fig. C)

2. Restraint belts must be adjusted as tightly as possible consistent with user comfort.

Restraint belt webbing must not be twisted when in use.

The upper torso restraint belt must fit over the shoulder and across the chest as illustrated in Fig.E. Always route the belt close to the user's body.

WARNING!

Never route the belt across wheels and/ or sideguards as displayed in Fig. D.

Fig. C

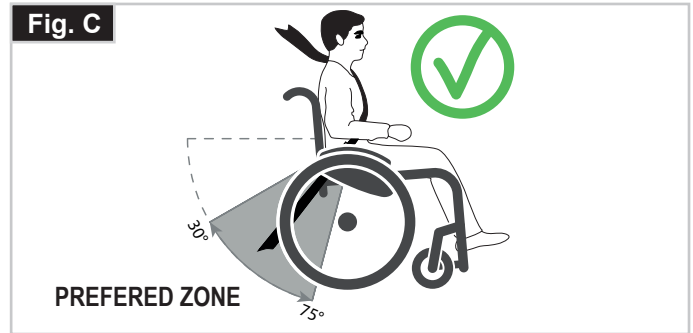

Fig. D

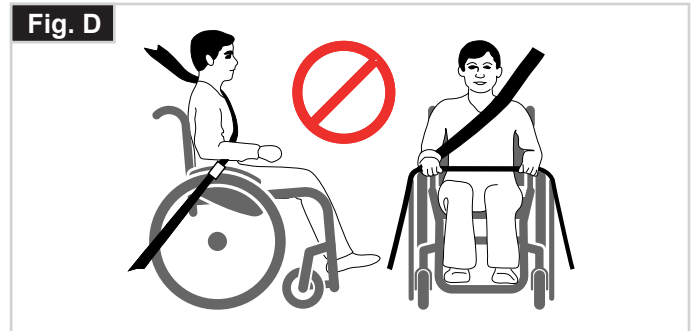
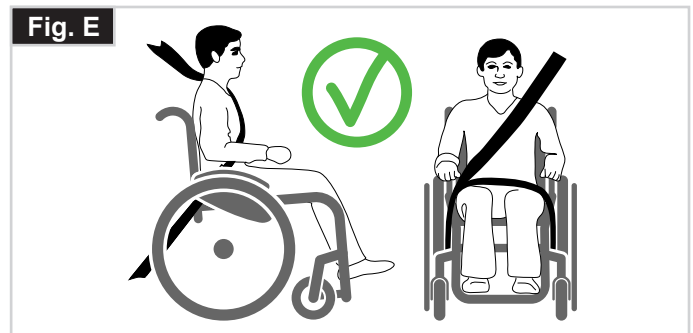

Fig. E



Occupant Restraints Instruction (continued):

3. The wheelchair can be tied down using the following attachment areas:
 - Front: area between the horizontal and vertical frame-tubes, just above the caster-links.
 - Rear: the loops bolted to the vertical rear frame-tube must be used.
4. The tie down symbol (Fig. F) on the wheelchair frame indicates the position of the wheelchair restraint straps. The straps are then tensioned after the front straps have been fitted to secure the wheelchair.

Positioning of wheelchair tie down restraints on wheelchair:

Location of the front and rear tie down labels (Fig.G - H).

Minimum User Weight 22 kg:

When the user being transported is a person weighing less than 22Kg, and the vehicle involved has less than eight (8) seated passengers, it is recommended that they be transferred to an UNCE Regulation 44 compliant child restraint system (CRS).

This type of restraint system provides a more effective occupant restraint system than the conventional 3 point occupant restraint system and some CRS systems also include additional postural supports to assist in maintaining the position of the child when seated.

Parents or care providers may consider the option, in some circumstances, for their child is to remain in their wheelchair whilst in transport due to the level of posture control and comfort provided by the set up in the wheelchair.

We would recommend in such circumstances that a risk assessment be carried out by your healthcare professional and relevant competent persons.

Fig. F

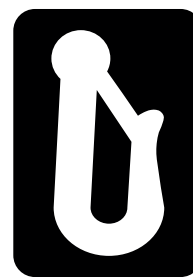

Fig. G



Fig. H



4.0 Handling

Folding up (Fig.4.0)

First remove the seat cushion from the wheelchair and flip up the (platform) footplate or the individual footplates. Take hold of the sling from underneath in the middle and pull upwards, until the folding bracket clicks into place, (Fig.4.0-4.1). To fold your wheelchair until it is as small as possible, e.g., to put into a car, you can remove the footrests (depending on the model). For this purpose, open the latch from the outside and swing the footrest to the side, (Fig.4.2-4.3). Then the footrest only has to be drawn out of the frame tubing.

Transportation

To move the mobility aid, the folded wheelchair should be lifted by holding the front part of the cross-brace and the push handles.

Unfolding

Push the release lever of the folding bracket (Fig. 4.4) downwards and push both frame halves apart. Then press on the seat tube (Fig.4.5). Your wheelchair is then unfolded. Now snap the seat tubing into position in the seat saddle. This can be facilitated by slightly tipping your wheelchair to the side, as this means that the weight is taken off one of the rear wheels. Be careful not to get your fingers caught in the cross-tube assembly. Fit the seat cushion.

WARNING!

Risk of finger entrapment.

Getting into your wheelchair on your own

- Push the wheelchair to a wall or a solid piece of furniture;
- Apply the brakes;
- The user can lower themselves into the wheelchair;
- Then position the feet in front of the heel straps (Fig. 4.6).

Getting out of your wheelchair on your own

- Apply the brakes;
- With one hand on the wheel or sideguard, the person should lean forwards slightly, to transfer the body weight to the front edge of the seat and then push up to an upright position with both feet firmly on the floor and one foot behind the other (Fig. 4.7).

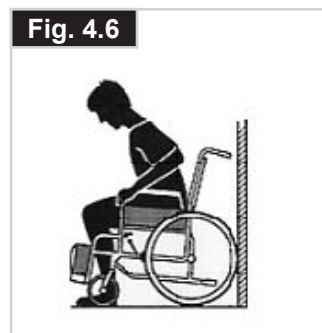
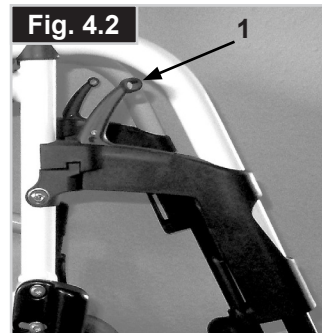

5.0 Transporting the Wheelchair

When transporting the unoccupied wheelchair in a vehicle, it should be tied down or strapped in.

Quick-Release Axles for Rear Wheels (Fig.5.0)

Removing the rear wheels will keep the wheelchair as compact as possible.

The rear wheels are equipped with quick-release axles. The wheels can thus be installed or removed without using tools. To remove a wheel, simply depress the quick-release button on the axle (1) and pull it out.

CAUTION!

Hold the quick-release button on the axle depressed when inserting the axle into the frame to mount the rear wheels. Release the button to lock the wheel in place. The quick-release button should snap back to its original position.

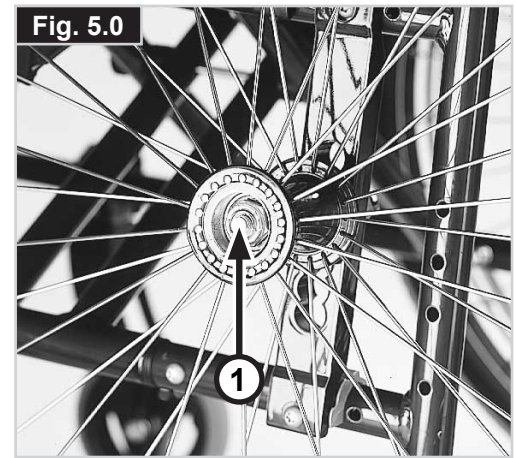

6.0 Options

6.1 Brakes

Wheel Locks (Fig.6.01-6.03.2)

Your wheelchair is equipped with two wheel locks. They are applied directly against the tyres. To engage, press both brake levers forward against the stops. To release the locks, pull the levers back to their original positions.

WARNING!

Braking power will decrease with:

- Incorrect fitting and adjustment of the brakes.
- Tyre pressure too low.
- Worn tyre tread
- Wet tyres
- Improperly adjusted wheel locks.
- The wheel locks have not been designed to be used as brakes for a moving wheelchair.
- The wheel locks should therefore never be used to brake a moving wheelchair.
- Always use the hand-rims for braking.

Make sure that the gap between the tyres and wheel locks complies with given specifications. To re-adjust, loosen the screw (1) and set the appropriate gap (Knee-lever brake Fig. 6.02, standard brake 6.03.2). Then re-tighten the screw (Fig. 6.01, 6.03.2). After each adjustment of the rear wheels, check the wheel lock gap and re-adjust if necessary.

Drum Brakes

Drum brakes permit safe and convenient braking for an attendant.

They can also be set with the aid of a locking lever (1) to prevent rolling.

The lever must snap audibly into place.

Drum brakes are not influenced by air pressure inside the tyres (Fig.6.04).

WARNING!

Drum brakes must only be adjusted by authorised dealers.

Always operate the two brakes simultaneously to guarantee the control of the driving direction!

Drum brakes can only be used as a dynamic brake to stop the wheelchair while driving.

Always engage the wheel locks to secure the wheelchair during a short or long stop, or for transfer.



Fig. 6.01

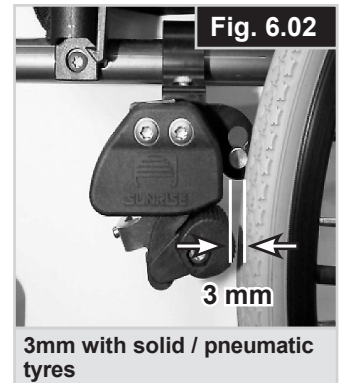

Fig. 6.02

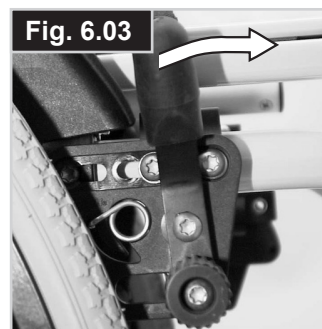

Fig. 6.03

Standard brake

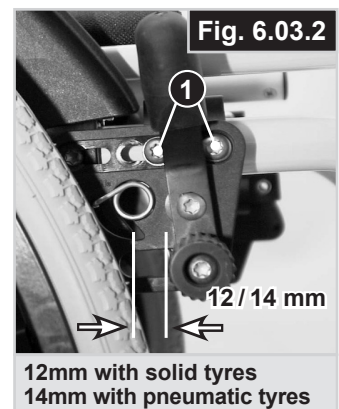

Fig. 6.03.2

12mm with solid tyres
14mm with pneumatic tyres

Standard brake

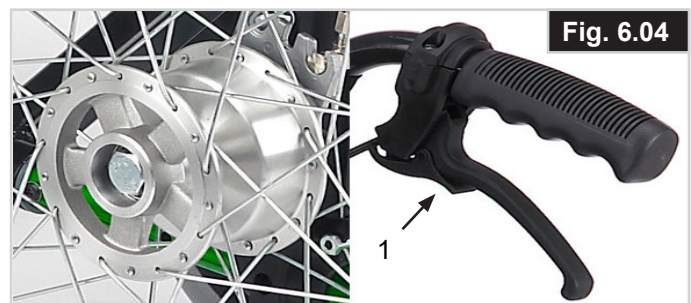

Fig. 6.04

Brake Lever Extension

The longer lever helps to minimise the effort needed to set the wheel locks. The brake lever extension is screwed to the brakes. By raising this, it can be flipped forward (Fig. 6.05-6.06).

CAUTION !

- Mounting the wheel lock too close towards the wheel will result in a higher effort to operate. This might cause the brake lever extension to break!
- Leaning onto the brake lever extension while transferring will cause the lever to break! Splashing water from tyres might cause the wheel lock to malfunction.

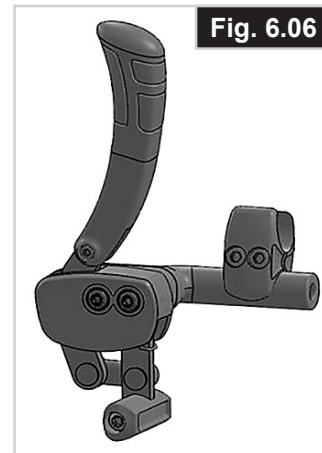
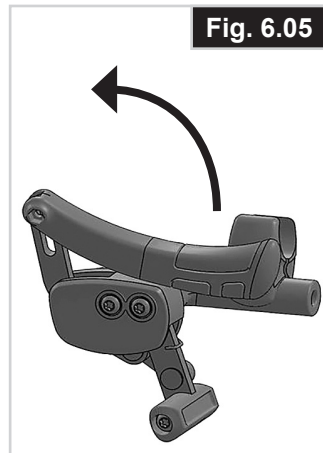

Compact wheel lock (Fig. 6.07)

Compact wheel locks are underneath the seat sling and are operated by pulling the wheel locks towards the rear, in the direction of the tyre. For the wheel locks to operate correctly, they must be pulled fully against the stops.

CAUTION!

- Incorrect mounting of the wheel lock will result in a higher effort to operate. This might cause the wheel lock lever extension to break!
- The mounting bolts of the brake must not be loosened and/ or re-tightened.



One Hand Wheel Locks

Your wheelchair is equipped with two sets of wheel locks, that operate from the left or the right side. They are applied directly against the tyres. To engage, press the wheel-lock lever forward against the stop (Fig.6.08). To release the wheel, pull the lever back to the original position.

- Braking power will decrease with:
 - Worn tyre tread
 - Tyre pressure that is too low
 - Wet tyres
 - Improperly adjusted wheel locks.

The wheel locks have not been designed to be used as brakes for a moving wheelchair. The wheel locks should therefore never be used to brake a moving wheelchair. Always use the handrims for braking. Make sure that the interval between the tyres and wheel locks complies with given specifications.

To readjust, loosen screws, (1), and set the appropriate interval, (Fig.6.09). Tighten screw (see the page on torque).



6.2 Step Tubes

Step tubes are used by attendants to push a wheelchair over an obstacle. Simply step on the tube to push a wheelchair, for example, over a kerb or step, (Fig.6.10).

The step tube is equipped with a hinge, so that it will fold upwards if it gets caught on i.e. a curbstone and therefore prevents damage and user injury.

CAUTION!

Sunrise Medical strongly recommends the use of a step tube on any model where attendant use is the predominant intended use. Damage to the backposts may occur if you constantly use the backpost without a step tube, as a lever to pull back on to tip the wheelchair.

6.3 Footrests

Various footboards are available on the QS5 X. These can be flipped up to make it easier to transfer to/from the chair. They are described individually.

Footrest and swing away latch

When fitting the footrests these are fitted in the swung-away position (Fig. 6.11). Then simply turn them inwards until the interlock engages (1). To remove the footrests, use the lever (2) and swing the footrest outwards and lift off. Check that the footrest is correctly engaged.

The footrest will be limited by the hanger stop (Fig.6.11) in a 90° position. This ensures that the break will not be inadvertently released when the hanger is swung out.

WARNING!

The footrests are not designed to be used to lift or carry the wheelchairs with an occupant.

Hanger play adjustment

In case of play the hanger (Fig. 6.12) can be adjusted in the field. The hanger pin (1) is tapered and the play can be reduced when the pin is unscrewed slightly.

Take the hanger off the chair in using the release mechanism.

Use a screwdriver and turn the pin (1) in the front carefully to the left. Then test the hanger on the chair. If the hanger mechanism is not working/catching anymore, please undo the task slightly.

If the play is still too large and the performance not accepted, please repeat the task.

Fig. 6.10

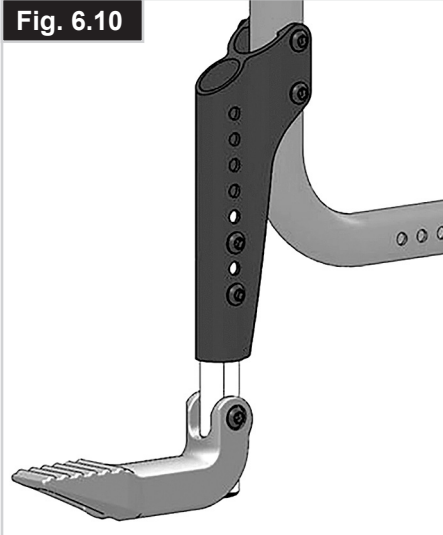

Fig. 6.11

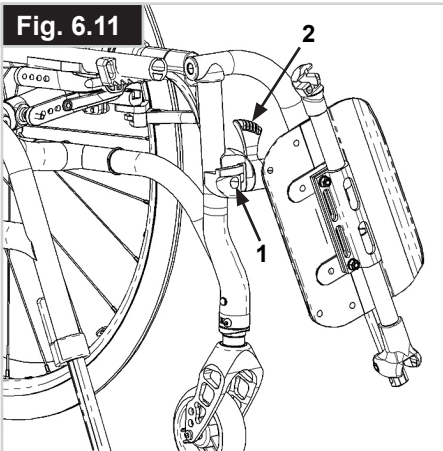
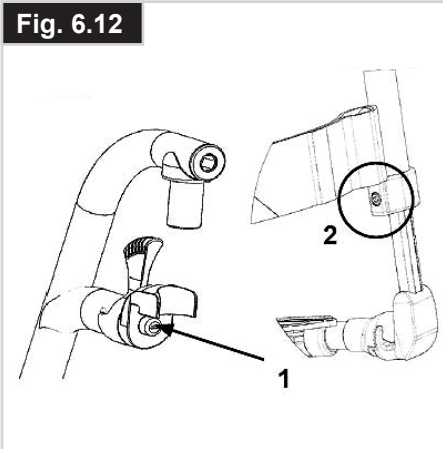

Fig. 6.12



Lower leg lengths

By undoing the clamp screw, 1 (Fig. 6.13), you can adjust the lower leg length. Loosen the clamp screw, adjust the tube with the footboard to the desired position.

Tighten clamp screws again (see the page on torque). Ensure that the plastic push joint is located under the clamp screw in the correct position.

WARNING!

Always maintain a minimum of 30mm between the lowest part of the footrest and the floor.

WARNING!

Do not stand on the footplate during transfer. The chair is likely to tip to the front when standing on the footplate. Always place your feet securely on the ground for transferring into or out of the chair.

Platform footplates: angle adjustment

To set the correct angle of the footplates relative to the ground, open the nuts (1) on the underside of the footplates and set the desired angle of the footplates. Tighten the nuts to the specified torque. (Fig. 6.14).

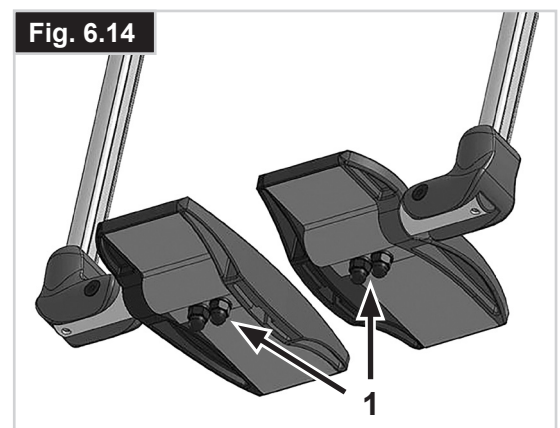
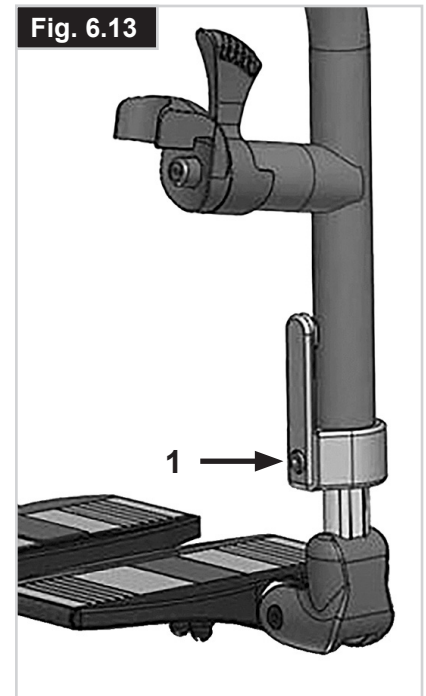

Lightweight footrest

The footrest angle can be adjusted by loosening the screws (2). Side protection panels can be fitted to the footrest using the mounting holes (3). These prevent the feet slipping off accidentally, (Fig. 6.15). Make sure that after any adjustment work, all screws are tightened correctly (see the page on torque).

Width adjustment

To adjust the width of the footrest please open the screw (2). Then you can slide in and out the tubes in the holder to adjust the width of the footboard (Fig. 6.15).

Please make sure that the screws are tightened with the correct torque.

Footboard lock

The footplate locks in automatically when flipped down. To flip it up the release knob (1) must be pulled. To keep the unlocked position turn knob 1 when it is pulled (Fig. 6.16).

WARNING!

Always make sure to unlock the system to get full functionality!

Elevating legrest - standard

To flip up:

Pull the footrest upwards and adjust to the desired height. When doing this, the footrest clicks audibly into place (Fig. 6.17).

To lower:

Briefly take the load off the footrest by lifting the lower leg and then push the release lever. In this way you can swing the footrest downwards. As soon as you let go of the lever, the footrest will click back into place.

WARNING!

- There is a risk of trapping fingers when moving the footrest up or down.
- Do not put your fingers in the adjusting mechanism between the frame and the moving parts of the footrest.
- The footrests are not designed to be used to lift or carry the wheelchairs with an occupant.
- When getting into or out of the chair, never stand on the footboards.

Amputee Support (Fig. 6.18).

The Amputee Support can be adjusted in every direction as required.

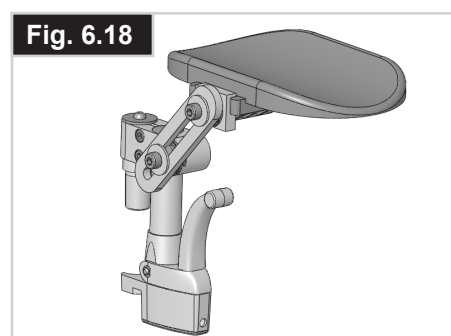
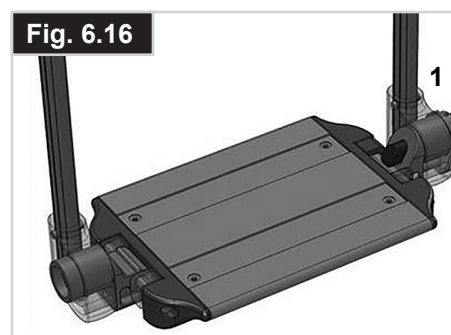

6.4 Castor

Castor, Castor adapter, Castor fork (Fig.6.19)

From time to time the wheelchair may veer slightly to the right or left or the castors may flutter. This may be caused by the following:

- Forward and/or reverse wheel motion has not been set properly.
- The castor angle has not been adjusted properly.
- Castor and/or rear wheel air pressure is incorrect; wheels do not turn smoothly.

The optimum adjustment of the castors is required so that the wheelchair runs in a straight line.

The castor plates must be re-adjusted, and the wheel locks must be checked every time the rear wheel position has been altered.

Adjusting the castor

Setting directional stability and fine-tune caster-height

These are works-settings and require special tools- please contact your dealer for support.

Adjusting the caster-fork angle

This adjustment is necessary when changing the front- or rear seat-height.

DANGER!

Failure to adjust the correct angle can result in caster-flutter, locking caster wheels and injury of the user. Loosen Allen screw (1) (Fig. 6.19). The caster-fork angle can now be adjusted to the correct position: the flat section of the fork must be positioned 90° to the ground. Use the markings (2) as optical aid for the adjustment. Once you have set the correct position, then tighten the Allen screw (1) to the specified torque.

DANGER!

Failure to tighten the Allen screw (1) (Fig. 6.19) correctly may result in unintended movement of the caster-fork and injury of the user.

DANGER!

Failure to adjust the castor link (1) in the caster-fork thread (2) (Fig 6.19.a) correctly may result in the caster-fork rotation and injury of the user. From initial factory set up, carbon assembly paste is used to increase friction. Do not remove the paste used in the interface in Figure 6.19.a. When replacing a new part (frame, caster-link as example) use the carbon assembly paste to assure correct adjustment.

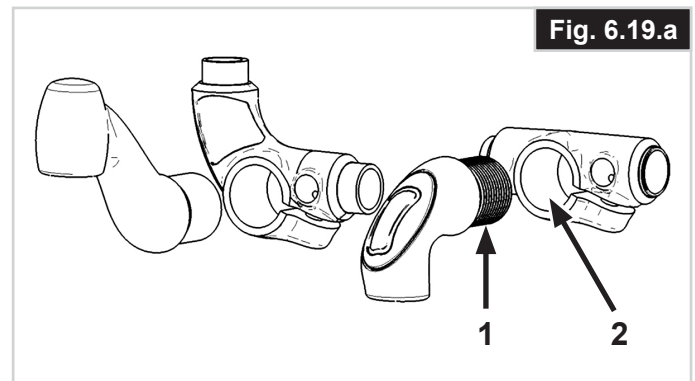
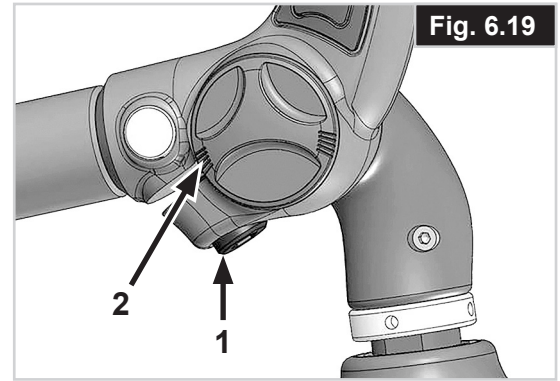

6.5 Adjustment of the Centre of Gravity (CoG)

The CoG can be adjusted in various positions between:

- Very passive: wheels are in a rearwards position, the chair is very stable and it's difficult to lift the front wheels to overcome obstacles.
- Very active: wheels are in a forward position, the chair is easier to maneuver, it's easier to lift the front wheels, however the chair can easily tip over to the rear

By moving the axle-plate (1) forwards (more active) or rearwards (more passive) on the frame, the CoG can be adjusted in 5 positions (Fig. 6.20).

To adjust CoG, proceed as follows:

Remove the rear-wheels. Loosen Allen bolt on top of the axle-plate (2). Remove Allen bolt on the bottom of the axle-plate (3) and finally remove the lid (4) including the set-screw. You can now slide the axle-plate in the desired position and re-assemble the lid (4) again. Make sure the set-screw fits into one of the holes on the frame.

Assemble the lower Allen bolt (3) and tighten both Allen bolts (2 and 3) to the specified torque.

WARNING!

Make sure to re-adjust wheel-locks and, if necessary, side guards according to the new position of the wheels. Failure to do so may result in user injury!

CAUTION!

Always make sure that the COG setting is the same on both sides.

DANGER!

Familiarize with the altered balance of the chair! When setting the CoG towards a more active position, the chair will become more prone to tip rearwards which might result in user injury. Be cautious and use anti-tips if necessary.

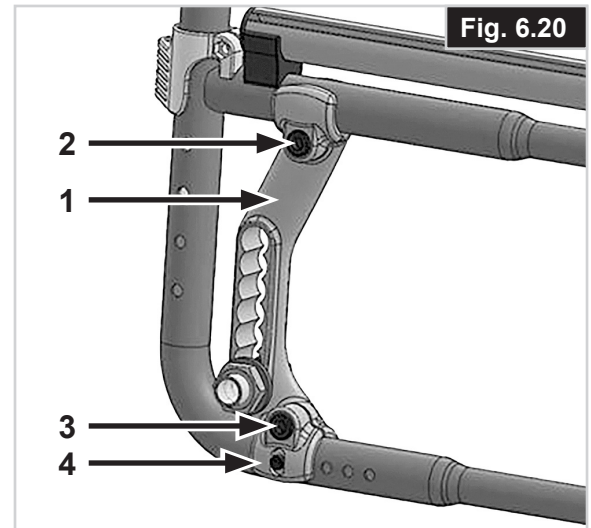

6.6 Backrest

Adjusting the backrest upholstery

Adjust the tension of the backrest's top-belt

Tear both Velcroed halves of the top belt apart (Fig.6.21) Tension the top-belt or remove tension. Once the desired strain is set, Velcro both halves back together.

In case of the top-belt laterally protruding over the push-handles, the belt can be cut to size with a pair of scissors. Cut the belt between the grey stitching. The stitching will prevent the belt from fraying.

Note for wheelchairs with fold-down push-handles

Do not use the Velcro-laces around the push-handles to set the strain of the belt (Fig.6.22). Those must be Velcroed to the top-belt using their full length.

Adjust the tension of the backrest-belts

Tension of the backrest-belts can be continuously adjusted using the Velcro-laces.

Delivery state, the Velcro-laces overlap by 20mm (Fig.6.23). This overlap allows you to adjust slack on the backrest-upholstery

When further tensioning the belts, the ends can laterally protrude. In these cases, the belts can be cut to size with a pair of scissors. Cut the belt between the black stitching. The stitching will prevent the belt from fraying.

CAUTION!

Please note that the tipping behaviour of the wheelchair will change if the backrest angle or backrest upholstery has been altered. This may mean that you need to use anti-tip tubes.

Angle-adjustable fixed back

The angle-adjustable backrest can be adjusted in seven positions in 5° increments.

By removing the nut (1) and the bolt, the angle can be adjusted to the desired angle.

Make sure to tighten the nut to the specified torque after the adjustment (Fig. 6.24).

WARNING!

For your own safety, adjustment work should always be carried out by your dealer.

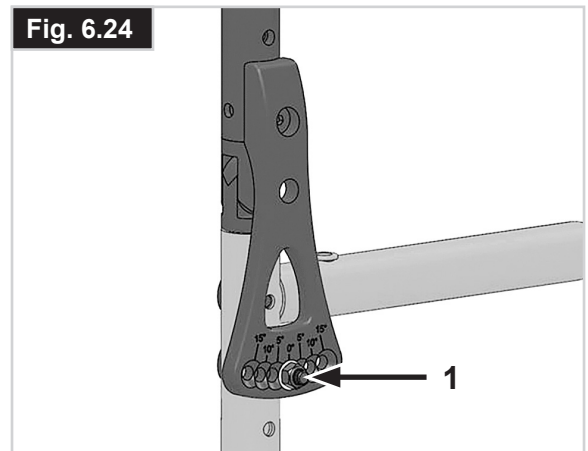
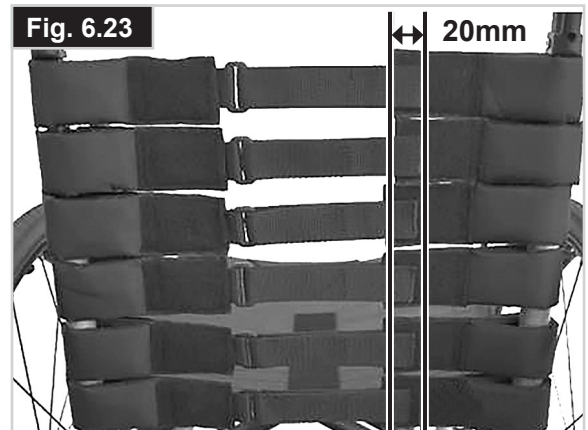
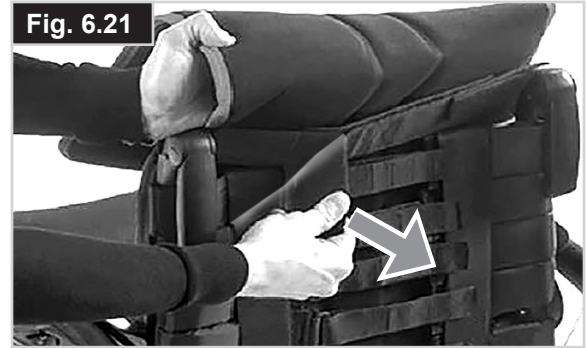

Folding backrest

To make it easier to transport the wheelchair, the top half of the backrest can be folded down (Fig. 6.25).

To do this, press both levers (1) and fold the backrest down. When folding the backrest back up, please make sure that both sides are firmly interlocked (Fig. 6.25/6.26).

⚠ WARNING!

- Risk of injury: do not get your fingers caught in the folding back mechanism.

⚠ WARNING!

Please take into account the altered centre of gravity when setting the angle of the backrest, tension of the backrest belts or backrest height. This may lead to an unstable wheelchair likely to tip and may require the use of anti-tip tubes.

Fig. 6.25



Fig. 6.26



6.7 Half Folding Back

Unfolding the backrest:

To put the backrest in the upright position, push the handles upwards and forwards until they lock in, (Fig.6.27).

WARNING!

Keep fingers and other items away from the folding mechanism when the backrest is being folded to prevent injury or damage to property.

WARNING!

Make sure that the backrest is always locked in correctly which is supported by the clicking noise. Not following this could cause serious injury.

Folding the backrest:

The backrest can be folded to make storage of the wheelchair easier, (Fig.6.28).

CAUTION!

Do not operate under load as this may cause lever to break.

To fold the backrest, stand behind the wheelchair, press the two small levers (Fig. 6.28) positioned on each side of the backrest (just above the armrests). Fold the backrest down.

6.8 Stabilising bar

Folding stabilising bar

This bar is used to stabilise the backrest.

To be able to fold the wheelchair, the release lever must be pushed inwards (Fig.6.29) or released and the stabilising must be flipped downwards. When unfolding the wheelchair, please make sure that the stabilising bar is locked into position.

Fig. 6.27



Fig. 6.28



Fig. 6.29



6.9 Headrests

Headrests

The headrest (Fig. 6.30) can be raised and moved horizontally both forwards and backwards.

To do this, loosen the screw (1,2 or 3).

Now you can adjust to the desired position. Tighten screws again (see the page on torque).

Fig. 6.30



6.10 Options – Hemiplegic armrest

Hemiplegic armrests

The hemiplegic armrest can be adjusted both in length and angle. You can adjust the length by pushing the armrest after having loosened the 2 rotary screws (1). To adjust the angle, open the release lever (2) and rotate the armrest to the desired position, then tighten it again (Fig. 6.31).

Fig. 6.31

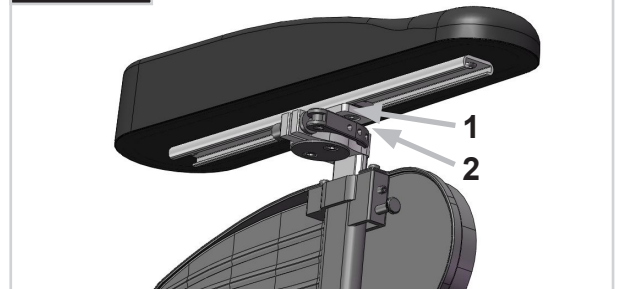

6.11 Sideguards

Desk Sideguard, Flip-Up, Detachable with Short or Long Armrests, Height-Adjustable (Fig.6.32-6.33)

For a more comfortable seating position, you can adjust the height of the armrest as follows:-

Adjust the height of the armrest as follows: Slide the knob (1) forward until it stops. Adjust the armrest (2) to the desired height. Slide the knob toward the back and push the armrest (2) down until you can hear it click into place. Always make sure that the sideguards have locked into place properly. To flip the armrest up, lift the handle (3) to unlock the sideguard.(Fig. 6.32)

To fully remove the sideguard, flip the sideguard fully up (1), then rotate slightly outwards (2) and pull out upwards (3).(Fig. 6.33)

⚠ CAUTION!

Neither the sideguards nor the armrests are to be used for lifting or carrying the wheelchair.

⚠ WARNING!

Always make sure that the armrests are properly locked after height-adjustments.

⚠ WARNING!

Do not use the armrest to push up or for transfers.

Fig. 6.32

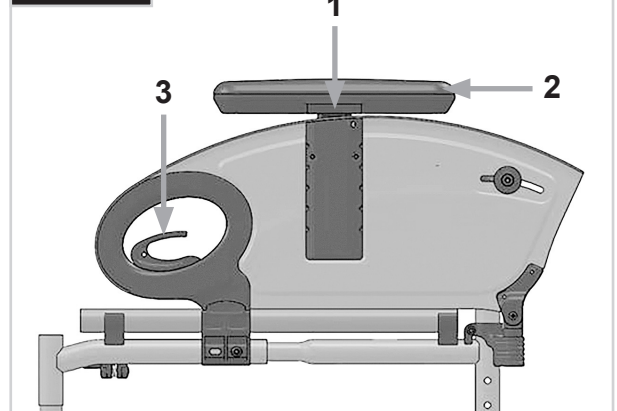
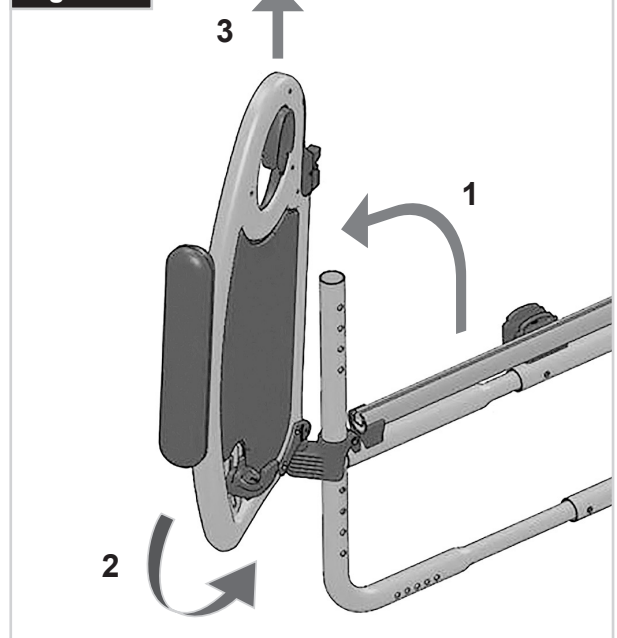

Fig. 6.33



Tool Height Adjustable Armrest

Installation: Slide the arm post into the receiver, located on the wheelchair frame, until it stops

Height adjustment:

Slide the arm rest post out of the receiver.
Adjust the position of the height adjustment bracket (1) by removing the screw (2) and moving it to the desired position. Re-fit the screw and tighten it.
Slide the arm rest post back into the receiver, (Fig.6.34).

Armpad Position:

The armpad position can be adjusted by releasing the screws (3), then moving the arm pad to the desired position. Re-tighten the screws, (Fig.6.34).

Adjusting Armrest Receiver

The tightness of the armrest receiver can be adjusted (tightened /loosened) by means of the 2 screws (1) - (Fig.6.35).

Sideguard With Clothes Protector (Fig.6.36)

The clothes protector prevents clothes getting dirty from spray water. You can set the position in relation to the rear wheel by moving the sideguard.
To do this, remove the fixing screws (1 and 2).
After setting to the desired position, re-tighten the screws (see the page on torque).

CAUTION!

Neither the sideguards nor the armrests are to be used for lifting or carrying the wheelchair

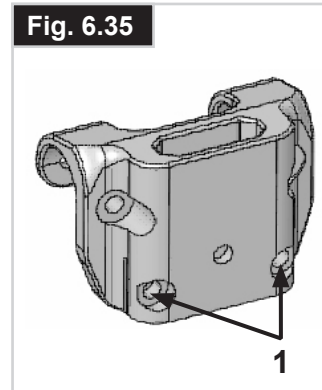
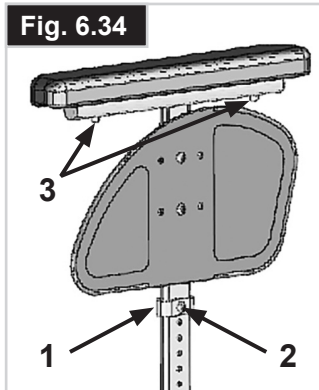

Single Post Height-Adjustable Armrests, (Fig.6.37).

CAUTION!

Neither the sideguards nor the armrests are to be used for lifting or carrying the wheelchair.

1. Fitting (Fig. 6.37)

- a. Push the outer armrest rails down into the receiver which is mounted on the wheelchair frame.
- b. The armrest will automatically lock into place.

2. Height Adjustment (Fig. 6.37)

- a. Turn the release lever for height adjustment (2) to the second stop point.
- b. Push the armpad up or down to reach the desired height.
- c. Set the lever back to the interlocked position against the armrest rails.
- d. Push the armpad (4) until the rails click into place securely.

3. Remove The Armrest (Fig. 6.37)

- a. Operate the lever 3 and lift the whole arm.

4. Insert Armrest (Fig. 6.37)

- a. Put the armrest back in the receiver, until the arm clicks into place.

1. Outer armrest rails
2. Height adjustment of the locking lever
3. Locking lever
4. Armrest Pad
5. Transfer bar
6. Sideguard
7. Receiver
8. Parts to adjust the receiver

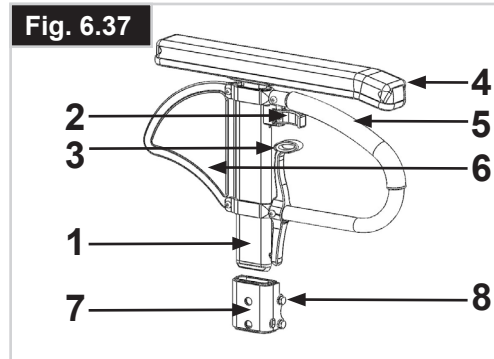

6.12 Options – One Hand Operation

One Hand Operation

(Fig. 6.38- 6.38.1)

To propel the chair in a straight line, both handrims must be used with one hand.

To fold the wheelchair, remove the telescopic bar by pushing both ends together.

WARNING!

Make always sure that the connections are set properly to avoid injuries.

Fig. 6.38



Fig. 6.38.1



6.13 Tray

Tray (Fig. 6.39)

The tray table serves as a surface area. Your dealer must carry out a one-off adjustment to the therapy tray so that it matches the seat width. When carrying out a function test, the user must be sitting in the wheelchair.

6.14 Push Handles

Height-Adjustable Push Handles (Fig.6.40)

These handles are secured with pins to prevent them from sliding out unintentionally. Opening the quick-release lever makes it possible to adjust the height of the push handles to meet your individual needs.

As you move the lever, you will hear a locking mechanism; you may now easily position the push handle as desired.

The nut on the tension lever determines how tightly the push handles are clamped into place. If the nut is loose after adjusting the tension lever, the push handle will also be too loose.

Turn the push handle from side to side before use to make sure that it is clamped securely enough into place.

After adjusting the handle height, always clamp the tension lever securely into place.

DANGER!

If the lever is not secure, it could result in serious injury when ascending stairs.

Fig. 6.39



Fig. 6.40



6.15 Push handle

Fold-Down Push Handles (Fig.6.41)

If the push handles are not in use, they can be folded down by depressing the button, (1). When they are needed again, simply flip them back up until they click into place.

Fig. 6.41



6.16 Anti-tip tubes

Anti-Tip Tubes (Fig.6.42)

The anti-tip tubes (1) provide additional safety for inexperienced users when they are still learning how to operate their wheelchairs. Anti-tip tubes (1) prevent a wheelchair from tipping over backwards.

You can swing the anti-tip tube underneath the chair by pushing it downwards and then rotate it clockwise (when mounted on the right) or counter-clockwise (when mounted on the left).

There should be a gap of 30 to 50mm to the floor. To go up or down a step (e.g. kerb) the anti-tip tubes must be swung forwards, to prevent them from touching the ground.

WARNING!

Incorrect setup of the anti-tips will increase the risk of a rearwards tip.

Fig. 6.42



Fig. 6.43

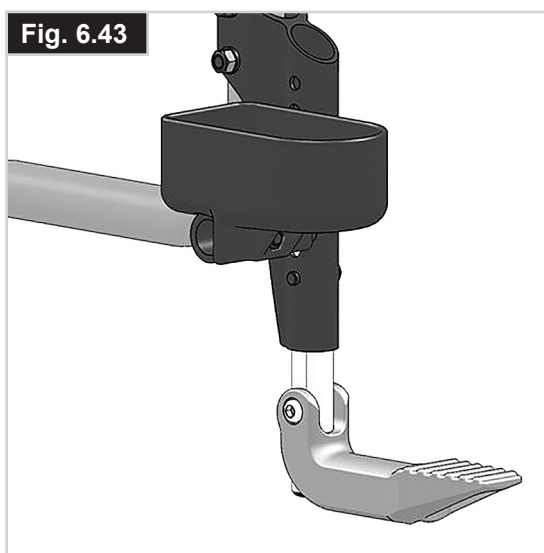

6.17 Crutch holder

Crutch Holder (Fig.6.43)

This device permits crutches to be transported directly on the wheelchair. It has a Velcro loop to fasten crutches or other aids.

CAUTION!

Never try to use / remove the crutches or other aids while moving.

6.18 LED Light

The optional LED lights are mounted on the frame, and can be detached for charging.

Switching the lights on:

By pushing the button **A** on the backside of each housing, you can cycle through operating-modes of the LEDs: (Fig. 6.45)

1. Full power mode
2. Low-power mode
3. Off

Remove the lights for charging:

Remove each Light by pushing the button on top of the housing **B**, and slide the housing towards the middle of the wheelchair.

To re-attach the Lights, mount them on the frame-support and slide towards the outside until you hear a clicking noise and the housing is locked in place. (Fig. 6.44)

Charge the battery:

Connect the USB-cable supplied with your wheelchair to the USB C connector (**C**) on the housing. Use a standard USB-charger or your Computer's USB-port to charge the battery. (Fig. 6.45)

Battery-type: Lithium-Ion
Nominal capacity: 320m Ah
Nominal voltage: 3.7 V
Charging-time: 1 hr.

Battery storage:

Store the LED lights in a dry and cool environment within a temperature range between -10 to +50°Celsius.

CAUTION!

Never try to open the housing!

Avoid the ingress of liquids or dirt into the LED lights box.

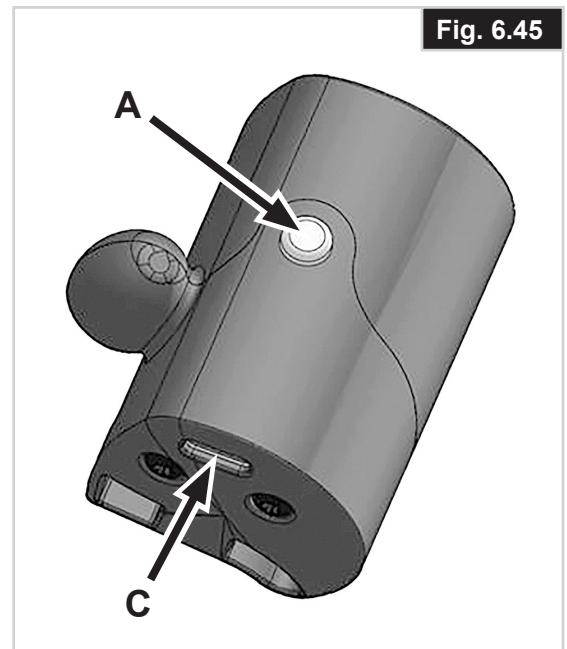
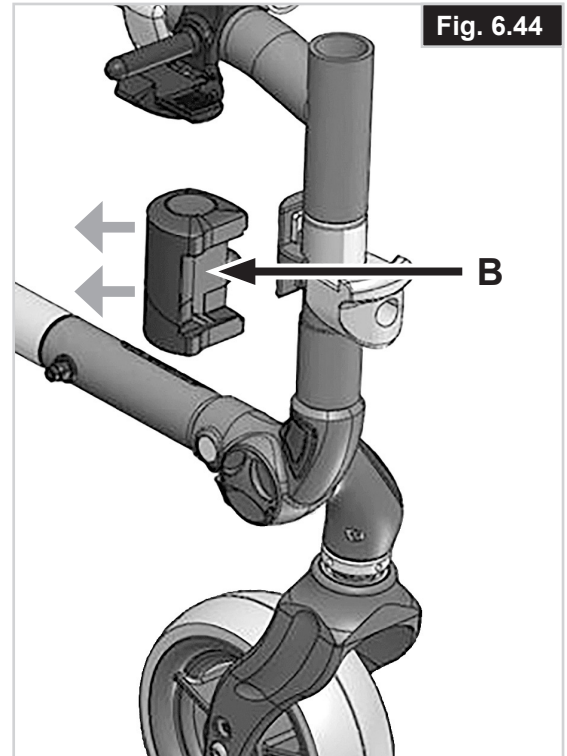

6.19 Pelvic Restraint Belt



⚠ DANGER!

- Before using your wheelchair ensure the lap belt is worn.
- The lap belt must be checked on a daily basis to ensure it is free from any obstruction or adverse wear.
- Always make sure that the lap strap is correctly secured and adjusted prior to use. If the strap is too loose it could cause the user to slip down and risk suffocation or cause serious injury.

The lap belt is fitted to the wheelchair as shown in the illustrations. The seat belt comprises 2 halves. They are fitted using the existing seat stay retaining bolt fitted through the eyelet on the belt. The belt is routed under the rear of the side panel. (Fig. 6.46)

Adjust the belt position so buckles are in the centre of the seat. (Fig. 6.47)

Adjust lap belt to suit the user's needs as follows:

To reduce the belt length	To increase the belt length
	
<p>Feed free belt back through male buckle and slide adjusters. Ensure belt is not looped at male buckle.</p>	<p>Feed free belt through slide adjusters and male buckle to provide more belt length.</p>

When fastened check space between the pelvic restraint belt and user. When correctly adjusted it should not be possible to insert more than the flat of the hand between the lap belt and the user. (Fig. 6.48).

The lap belt should be fixed so that the belt sits at an angle of 45 degrees across the user's pelvis. The user should be upright and be as far back as possible in the seat when correctly adjusted. The lap belt should not allow the user to slip down in the seat. (Fig. 6.49)

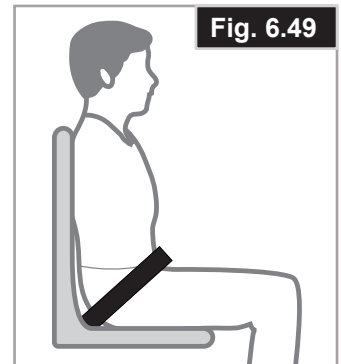
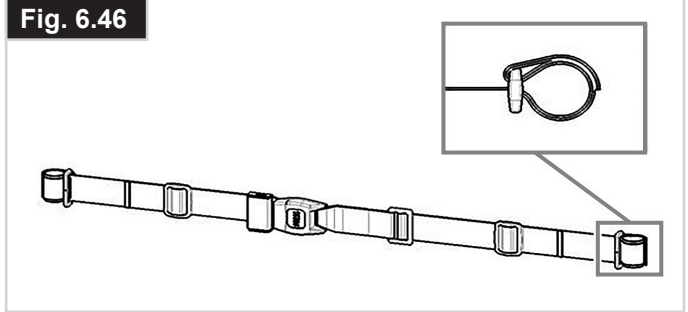

WARNING!

- If in doubt about the use and operation of the lap belt then ask your healthcare professional, wheelchair dealer, carer or attendant for assistance.
- If you want to retrofit a lap belt, then please contact your authorised Sunrise Medical dealer.
- The lap belt must be checked on a daily basis to ensure it is adjusted correctly and free from any obstruction or adverse wear.
- Sunrise Medical does not encourage the transportation of any person in a vehicle using this lap belt as a method of restraint.



Please see Sunrise Medical transit booklet for further advice on transportation.

Maintenance:

Check lap belt and securing components at regular intervals for any sign of fraying or damage. Replace if necessary.

WARNING

The lap belt should be adjusted to suit the end user as detailed above. Sunrise Medical recommends that the length and fit of the belt be checked on a regular basis to reduce the risk of the end user inadvertently re-adjusting the belt to an excessive length.

6.20 Transit wheels

Transit Wheels (Fig.6.50)

Travel wheels should be used wherever your wheelchair would be too wide if the rear wheels were used. After the rear wheels have been removed with the aid of the quick-release axles, the transit wheels can immediately be used to continue riding. The transit wheels are mounted so that they are approx. 30 mm above the ground when not in use. They are thus out of the way when riding, transporting, or when tipping to pass over obstacles.

CAUTION!

Without rear wheels, your wheelchair has no wheel locks.



Fig. 6.50

7.0 Tyres and Mounting

Solid rubber tyres are standard.

With pneumatic tyres always make sure that the tyres have the correct air pressure, as otherwise the performance of the wheelchair may be affected. If the tyre pressure is too low, rolling resistance will increase, requiring more effort to move the chair forward. Low tyre pressure also has a negative impact on manoeuvrability. If the tyre pressure is too high, the tyre could burst. The correct pressure for a given tyre is printed on the surface of the tyre itself.















Tyres are mounted the same way as an ordinary bicycle tyre. Before installing a new inner tube, you should always make sure that the base of the rim and the interior of the tyre are free of foreign objects. Check the pressure after mounting or repairing a tyre. It is critical to your safety and to the wheelchair's performance that regulation air pressure be maintained and that tyres be in good condition.

8.0 Name Plate













Name Plate

The nameplate is located on either the cross-tube assembly or the transverse frame tube. The nameplate indicates the exact model designation and other technical specifications. Please provide the following pieces of information whenever you have to order replacement parts or to file a claim:

- Serial number
- Order number
- Month/Year

TYPE:	Product Name/SKU Number.
	Maximum safe slope with anti-tip tubes fitted, Depends on wheelchair setting, posture and physical capabilities of the user.
	Seat width.
	Seat depth.
	Load Maximum.
	UKCA Mark.
	CE Mark.
	Consult instructions for use.
	Date of manufacture.
	Serial number.
	This symbol means Medical Device.
	Manufacturer's address.
	Crash tested according to ISO 7176-19:2022.
	Importer's address
	UK Responsible Person
	Swiss Representative's address

SAMPLE

	 Sunrise Medical GmbH Kahlbachring 2-4 D-69254 Malsch / Germany	 2022-XX-XX			
TYPE:	Rollstuhl	 203211733451939			
QS5 X	ISO 7176-19:2022				
 XXX kg	 max X°	 XXX mm	 XXX mm	 	 

UK	RP	Sunrise Medical Limited Thorns Road, Brierley Hill West Midlands, DY5 2LD UNITED KINGDOM
-----------	-----------	---



ISO 7010-M002
Instruction manual/booklet
must be read! (Blue Icon)



9.0 Maintenance and care

General Maintenance

DANGER!

- Check the brakes approximately every 4 weeks to make sure that they are working properly and are easy to use.
- All of the joints that are critical to using your wheelchair safely are self-locking nuts. Please check every three months to make sure that all bolts are secure (see the section on torque).
- Safety nuts should only be used once and should be replaced after use.
- You should only use genuine parts approved by Sunrise Medical. Do not use parts from other manufacturers, that have not been by authorised by Sunrise Medical.

CAUTION!

- Check the tyre pressure every 4 weeks.
- Check all tyres for wear and damage.
- Change tyres as you would an ordinary bicycle tyre.
- Please use only mild household cleansers when your wheelchair is dirty. Use only soap and water when cleaning the seat upholstery.
- If your wheelchair should ever get wet, please dry it afterwards.
- A small amount of sewing-machine oil should be applied to quick-release axles approximately every 8 weeks. Depending on the frequency and type of use, we recommend taking your wheelchair to your authorised dealer every 6 months to have it inspected by trained personnel.
- If you want to store the wheelchair for a long period of time, then no further measures are required. Make sure that the wheelchair is stored at room temperature in a dry place which is protected from strong sunlight. Before using it again, the wheelchair should be checked by an authorised dealer.

CAUTION!

Sand and sea water (or salt in the winter) can damage the bearings of the front and rear wheels. Clean the wheelchair thoroughly after exposure.

The following parts can be removed and sent back to the manufacturer/dealer for repair:

- Rear wheels
- Armrest
- Anti-Tip tubes

These components are available as spare parts. For further information, please see the spare parts catalogue.

Hygiene measures when being re-used:

Prior to the wheelchair being re-used, it must be carefully prepared. All surfaces which come into contact with the user must be treated with a disinfection spray.

To do this, you must use a disinfectant as authorised/recommended in your country, for rapid alcohol-based disinfection for medical products and medical devices, which must be disinfected quickly.

Please take into account the manufacturer's instructions for the disinfectant you are using.

In general, a complete disinfection cannot be guaranteed on seams. We therefore recommend that you dispose of seat and back slings to avoid micro-bacterial contamination with active agents according to your local infection protection law.

CAUTION!

- Excessive use of chemical or use of incorrect chemicals can lead to corrosion or degradation of materials used.
- Body-fluids can lead to corrosion or degradation of materials used. Make sure to clean and disinfect all parts of the wheelchair after contact with body-fluids.

10.0 Trouble shooting

Wheelchair pulls to one side

- Check tyre pressure
- Check to make sure wheel turns easily (bearings, axle)
- Check the castor angle
- Check to make sure both castors are making proper contact with the ground

Castors begin to wobble

- Check the castor angle
- Check to make sure all bolts are secure; tighten if necessary (see the section on torque)
- Check to make sure both castors are making proper contact with the ground

Wheelchair squeaks and rattles

- Check to make sure all bolts are secure; tighten if necessary (see the section on torque)
- Apply small amount of lubrication to spots where movable parts come in contact with one another

Wheelchair begins to wobble

- Check angle at which castors are set
- Check tyre pressure
- Check to see if rear wheels are adjusted differently

11.0 Disposal / recycling of materials

NOTE: If the wheelchair has been supplied to you free of charge it may not belong to you. If it is no longer required follow any instructions given by the organisation issuing the wheelchair in order that it may be returned to them.

The following information describes the materials used in the wheelchair in relation to the disposal or re-cycling of the wheelchair and its packaging.

Specific waste disposal or recycling regulations may be in force locally and these should be taken into consideration when disposal arrangements are made. (This may include the cleaning or de-contamination of the wheelchair before disposal).

Aluminium: Castor forks, wheels, side frames, armrests, frame, leg rests, push handles

Steel: Fasteners, QR axle

Plastic: Handgrips, tube plugs, castor wheels, footplates, armpads and 12" wheel/tyre

Packaging: Low density polythene bag, cardboard box

Upholstery: Woven polyester with PVC coatings and expanded combustion modified foam.

Battery for LED Lights: Lithium Ion battery (hazardous product)

Electrical and electronic equipment need to be disposed of separately to general household waste at specific state- provided locations. The correct disposal and separate collection of used appliances serves to prevent potential damage to health and the environment. It is a requirement for the re-utilisation and recycling of used electrical and electronic equipment.

Detailed information on the disposal of your used equipment can be obtained from your local authority, your waste disposal service, the specialist dealer from which you purchased the product, or your sales contact.

Disposal or recycling should be done through a licensed agent or authorised place of disposal. Alternatively your wheelchair may be returned to your dealer for disposal.



12.0 Technical Specifications

Overall width:

With standard wheels including handrims, close mount:

- in combination with desk sideguard: SW + 200 mm
- in combination with aluminium sideguard: SW + 180 mm
- in combination with plastic clothes protector: SW + 190 mm
- With extra-narrow handrim fitting, overall width is reduced by 20 mm

Folded dimensions:

- with rear wheels approx. 320 mm
- without rear wheels approx. 270 mm

Weight in kg:

- Transportation (without wheels) 7.5 kg
- Wheels (pair) 2.6 kg

Maximum user weight:

- QS5 X up to a load of 140 kg
(136 kg crash tested)

ADDITIONAL NOTES

In Accordance with EN12183: 2022 all there listed parts are fire resistant as per EN1021-2.

WARNING!

The Dynamic safe slope is dependent on the chair configuration, the users abilities and the style of riding. As the users abilities and style of riding cannot be predetermined then the max safe slope cannot be determined. Therefore this must be determined by the user with the assistance of an attendant to prevent tipping.

It is strongly recommended that inexperienced users have Ant-tips fitted.

The wheelchair conforms to the following standards:

- a) Requirements and test methods for static, impact and fatigue strengths (ISO 7176-8)
- b) Requirements for resistance to ignition in accordance with ISO 7176-16 (EN 1021-1)

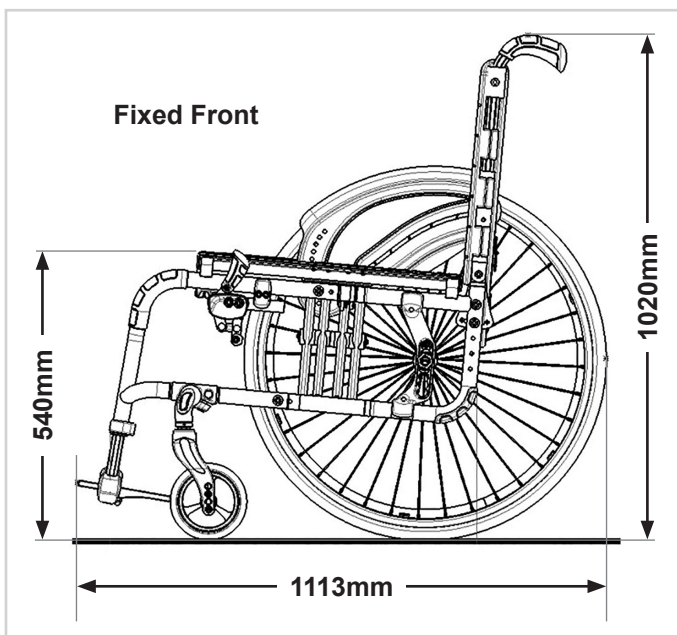







Sunrise Medical S.r.l.
Via Riva, 20 – Montale
29122 Piacenza
Italia
Tel.: +39 0523 573111
Fax: +39 0523 570060
www.SunriseMedical.it

Sunrise Medical AG
Erlenauweg 17
CH-3110 Münsingen
Schweiz/Suisse/Svizzera
Fon +41 (0)31 958 3838
Fax +41 (0)31 958 3848
www.SunriseMedical.ch

Sunrise Medical AS
Delitoppen 3
1540 Vestby
Norge
Telefon: +47 66 96 38 00
post@sunrisemedical.no
www.SunriseMedical.no

Sunrise Medical AB
Neongatan 5
431 53 Mölndal
Sweden
Tel.: +46 (0)31 748 37 00
post@sunrisemedical.se
www.SunriseMedical.se

MEDICCO s.r.o.
H – Park, Heršpická 1013/11d,
639 00 Brno
Czech Republic
Tel.: (+420) 547 250 955
Fax: (+420) 547 250 956
www.medicco.cz
info@medicco.cz
Bezplatná linka 800 900 809

Sunrise Medical Aps
Mærkærvej 5-9
2630 Taastrup
Denmark
+45 70 22 43 49
info@sunrisemedical.dk
Sunrisemedical.dk

Sunrise Medical Australia
11 Daniel Street
Wetherill Park NSW 2164
Australia
Ph: +61 2 9678 6600
E: enquiries@sunrisemedical.com.au
www.SunriseMedical.com.au

Sunrise Medical
North American Headquarters
2842 Business Park Avenue
Fresno, CA, 93727, USA
(800) 333-4000
(800) 300-7502
www.SunriseMedical.com



Sunrise Medical GmbH
Kahlbachring 2-4
69254 Malsch/Heidelberg
Deutschland
Tel.: +49 (0) 7253/980-0
Fax: +49 (0) 7253/980-222
www.SunriseMedical.de

Sunrise Medical
Thorns Road
Brierley Hill
West Midlands
DY5 2LD
England
Phone: 0845 605 66 88
Fax: 0845 605 66 89
www.SunriseMedical.co.uk

Sunrise Medical S.L.
Polígono Bakiola, 41
48498 Arrankudiaga – Vizcaya
España
Tel.: +34 (0) 902142434
Fax: +34 (0) 946481575
www.SunriseMedical.es

Sunrise Medical Poland
Sp. z o.o.
ul. Elektronowa 6,
94-103 Łódź
Polska
Telefon: + 48 42 275 83 38
Fax: + 48 42 209 35 23
E-mail: pl@sunrisemedical.de
www.Sunrise-Medical.pl

Sunrise Medical B.V.
Groningehaven 18-20
3433 PE NIEUWEGEIN
The Netherlands
T: +31 (0)30 – 60 82 100
F: +31 (0)30 – 60 55 880
E: info@sunrisemedical.nl
www.SunriseMedical.nl

Sunrise Medical HCM B.V.
Vossenbeemd 104
5705 CL Helmond
The Netherlands
T: +31 (0)492 593 888
E: customerservice@sunrisemedical.nl
www.SunriseMedical.nl
www.SunriseMedical.eu
(International)

Sunrise Medical SAS
ZAC de la Vrillonnerie
17 Rue Michaël Faraday
37170 Chambray-Lès-Tours
Tel : +33 (0) 2 47 55 44 00
Email: info@sunrisemedical.fr
www.sunrisemedical.fr

