

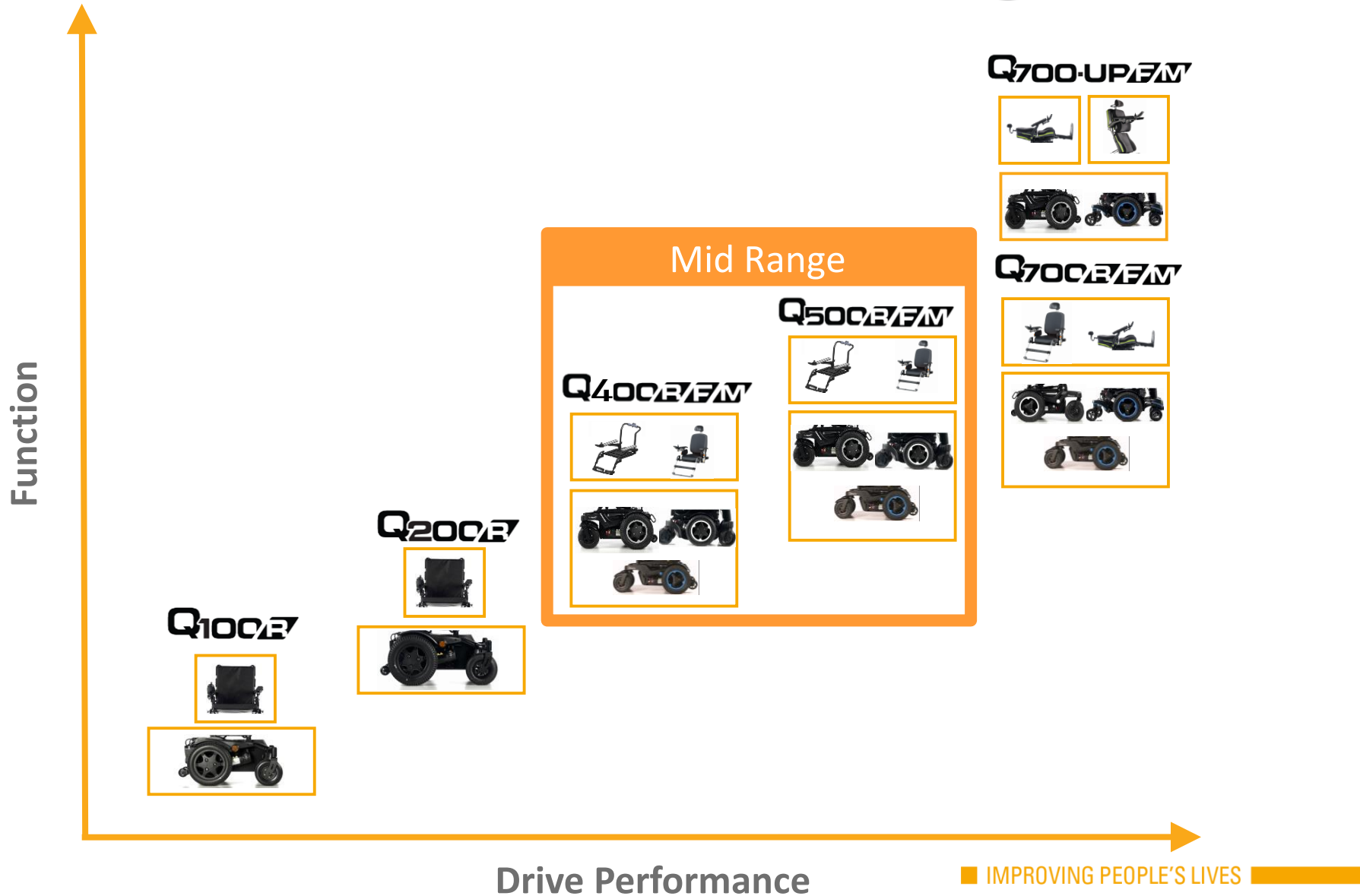

Q500 H
SEDEO PRO

***A NEW GENERATION
OF POWERCHAIR***

Design Concept



Design Concept



THE Q500 SERIES OFFERS...

Q500 R/FM



- ✓ Exceptional Performance
- ✓ Market Leading SEDEO Seating
- ✓ Advanced Control Systems
 - R-Net
 - Switch-IT SID's
 - Link-It
- ✓ Q-Series modularity

Q500 R Customer Feedback



Good Kerb Climbing

Good outdoor Performance

Popular - Habitual users

Good Stability - Max safe slope

Powered (clinical) Options



Firmer ride

Harder to drive - not so intuitive

Challenges for some users:

Reduced indoor manoeuvrability

Longer overall length

Reduced traction - down slopes

Q500 M Customer Feedback



Superb indoor manoeuvrability

Smallest turning circle

Popular

Easy to drive

Good stability - level surfaces

Good outdoor Performance

All Powered Options



Challenges for some users:

Pitching

Smaller Drive wheels and castors

Reduced outdoor Performance

Reduced Kerb Climbing

Limited dynamic stability

Luca MWD Customer Feedback



Easy to drive -
intuitive

Popular

Highly
Manoeuvrable

Good outdoor
Performance

Powered (clinical)
Options



Challenges for
some users:

To be discontinued
Not as manoeuvrable
as a Q500 M

Max speed
only 10kph

No SEDEO PRO
Seat option

Limited Kerb
climbing

Design Concept



Q500 M & LUCA MWD

Q500 R

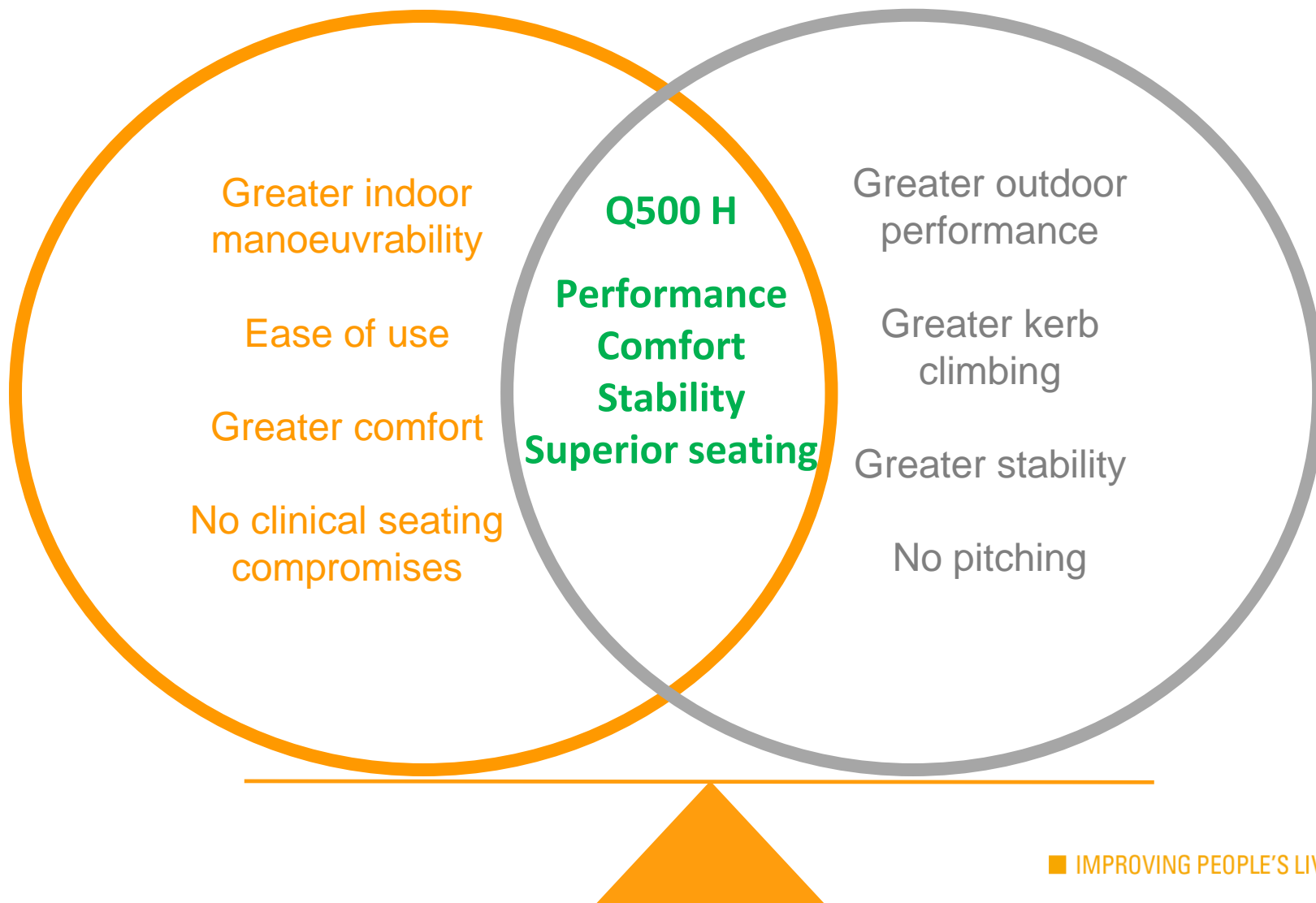

Greater indoor
manoeuvrability

Ease of use

Greater comfort

No clinical seating
compromises

Q500 H

Performance
Comfort
Stability
Superior seating

Greater outdoor
performance

Greater kerb
climbing

Greater stability

No pitching

Develop a Q500 H which offers

- **Improved drive base performance over RWD technology**
- **Unique compromise between MWD and RWD**
- **Q-Series component modularity**
- **Highly configurable SEDEO PRO seat system**
- **Solution for discontinuation of LUCA MWD**

Who will benefit from a Q500 H?



✓ Traditional RWD users

- need greater manoeuvrability, performance and comfort

✓ Caregiver who drive with attendant controls

RWD – difficult to manoeuvre
MWD – too responsive

✓ Older Care Home users

RWD – difficult to manoeuvre
MWD – too responsive

✓ Users requiring medical equipment (mounted at rear)

RWD – difficult to manoeuvre
MWD – altered COG - can lift front castors and 'feel' unstable

Users for whom RWD or MWD technology simply does not work

✓ Faster RWD powerchair users

- needing faster speed and manoeuvrability (e.g. Sports powerchairs)

✓ Users with chronic pain conditions

(e.g. severe Rheumatoid Arthritis)
RWD - find ride too firm
MWD - don't like the pitching



Q500 H
SEDEO PRO

***A NEW GENERATION
OF POWERCHAIR***

The Q500 H SEDEO PRO is a rear wheel drive hybrid powerchair

USP:

- *Innovative dynamic suspension - ensures six wheel contact with the ground to offer a smooth ride and increased stability over thresholds and rough terrain*

KSF:

- *True modularity – same core Q-series base and SEDEO seat components for easier ordering & fleet maintenance*
- *Exceptional ride comfort – from advanced dynamic suspension*
- *Effective obstacle climbing – up to 85mm without needing a kerb climber*
- *SEDEO PRO seat - modular, easy to adjust and quickly adaptable to changing user needs*

Technical Features – Base



Feature

✓ **True modularity** – utilises Q-Series core components as Q500 series power bases

- Drive wheels
- Castors
- Batteries
- Electronic control systems

Benefit

- Dealer - Easier to service and maintain
 - Enables true fleet maintenance
- User - Shorter maintenance visits



Technical Features – Base



Feature

- ✓ 13 or 14" Drive wheels
 - 6 spoke, split rim
 - 13" Pneumatic or solid - Knobby tyres
 - 14" Pneumatic or solid - Knobby tyres
- ✓ 9" front castors – solid or pneumatic tyres
 - Optional castor wheel mudguards

Benefit

- Dealer - Easier to maintain & service
- Dealer & User - Better match user need – balances indoor manoeuvrability with greater outdoor performance



Technical Features – Base



Feature

- ✓ 50/60/80 Ah batteries
- ✓ Same STFH options
 - 415mm to 490mm
- ✓ Max user weight 160kg

Benefit

- Accommodates users with broader range of power chair needs
 - Greater range
 - Frequent seat position changes
 - Heavier users
- Standard with SEDEO PRO seat to effectively meet majority of powerchair user needs



Technical Features – Base



Feature

✓ Total width

- Minimum 620mm - 13" drive wheels (5mm wider than Q500 R)
- Maximum 640mm - 14" drive wheels (same as Q500 R)

Benefit

- Easily accesses indoor environments whilst offering good lateral stability outdoors



Width 620- 640mm

Drive wheel position

Turning Point



Q500 M 1280mm



Q500 H 1195mm



Q500 R 1110mm

- Minimum Turning Radius

Q500 M 560mm

Q500 H 910mm

Q500 R 950mm

- Total length (incl S/A footrests)

Q500 M 1280mm

Q500 H 1195-1280mm

Q500 R 1110-1180mm

Technical Features



Feature

- ✓ Q500 H has a **shorter minimum turning radius** (than Q500 R)
- ✓ **Longer total length** than (Q500 R)

Benefit

- Greater manoeuvrability
- Greater 'feeling' of stability due to longer footprint – especially important:
 - When using tilt, recline and ELR's
 - Users lacking postural stability
 - For taller users – whose COG is more rearward



Technical Features - Stability



Feature

- ✓ **Dynamic stability – Same as RWD**
Maximum safe slope of 10°

- Q500R 10°
- **Q500 H 10°**
- Q500M 6°

- ✓ **Static stability**

- Q500R
- **Q500 H – all 13/15/13°**
- Q500M

Benefit

- Excellent overall stability as with RWD but 'feeling' of added stability due to longer wheelbase



Technical Features - Suspension

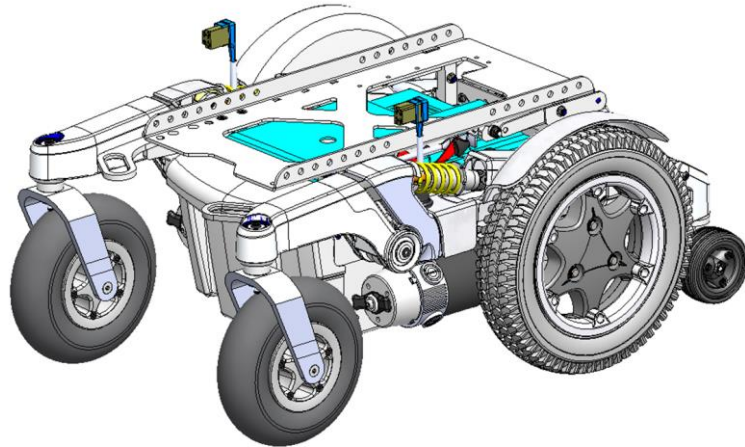

Feature

✓ Innovative suspension system

- Adjustable spring suspension with dampeners
- Independent rear active anti-tip wheels



Benefit

- Ensures all wheels remain in contact with the ground for optimum stability
- Allows smooth kerb climbing of up to 85mm without a kerb climber

Technical Features - Suspension

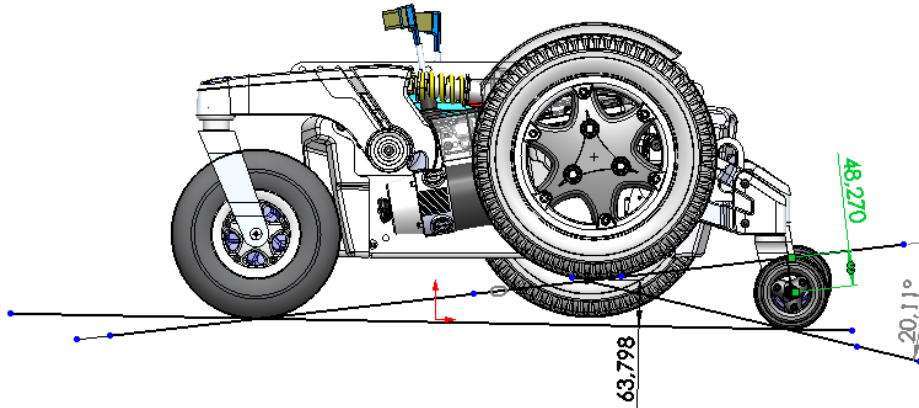
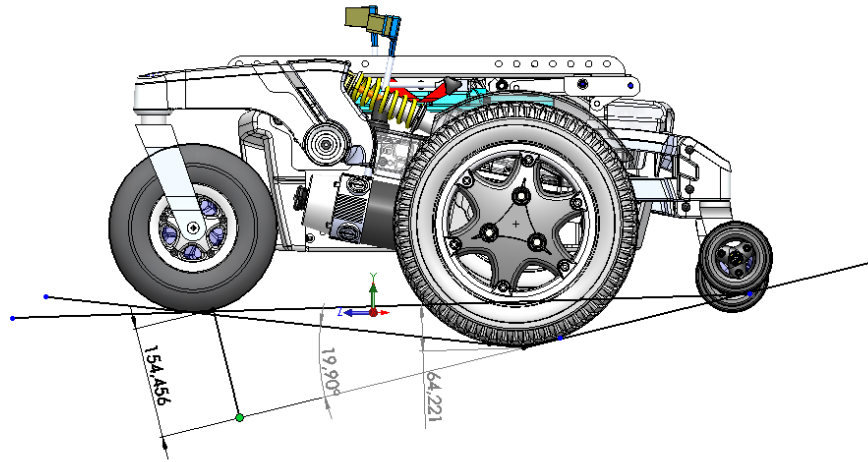

The system can accommodate opposite deviations in terrain while keeping the seat level and all wheels in contact with the ground

Compared to a RWD the ride will be:

- Smoother and less firm
- Greater traction
- Greater feeling of stability

Compared to a MWD the ride will be:

- More comfortable
- More stable
- Greater kerb climbing ability

Technical Features - Suspension

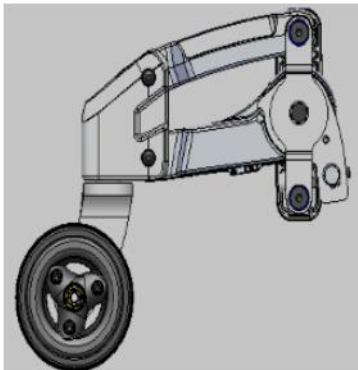
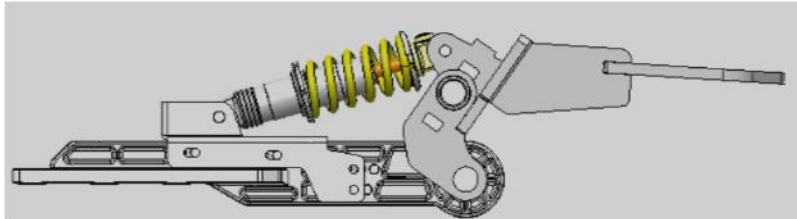

Components

✓ Shock absorber

1. Coiled spring (550 lbs)
2. Oil dampened (rebound)
3. 50 mm stroke

✓ Anti tip (auxiliary suspension)

1. Torsilastic (15,7 in-lb/deg), in parallel bars – resistance to upward movement
2. Range 17° (20mm up and down vertical movement)
3. 4" Anti tip wheel

Technical Features – Seat



Feature

- ✓ Fitted with SEDEO PRO seat as standard
 - One tool adjustment
 - Full powered seat functionality
 - Integrated SEDEO, JAY and Whitmyer
 - Extensive Switch-IT SID's and Link-IT options

Benefit

- Easy to use and adaptable to meet moderate-complex seating needs
- Reduced clinical compromises
- Easy maintenance – modularity across SEDEO seating range

HYBRID VS Q500 R VS LUCA MWD VS Q500 M



	Hybrid	Q500 R	LUCA MWD	Q500 M
Overall maximum length incl S/A footplates	1195mm	1110mm (-85mm)	1180mm (-150mm)	1280mm
Turning radius	910mm	950mm (+40mm)	770mm	560mm
Static stability	13/15/13	13/15/13	15/15/15	13/15/13
Max safe slope	10°	10°	10°	6°
Kerb climbing	85mm	80/ 100mm* (*with Kerb Climber)	60mm	50mm
Max Battery Range	40km	40km	35Km	40km

SUMMARY

Q500 H SEDEO PRO utilizes an innovative, dynamic suspension system to ensure six wheel contact with the ground to offer a smooth, comfortable ride and increased stability over thresholds and rough terrain

It will benefit:

- Traditional mid-range RWD users who need greater manoeuvrability, comfort and outdoor performance but who cannot make the change to MWD technology
- Mid-range MWD users who want enhanced outdoor performance, greater all round stability and comfort who cannot change to traditional RWD technology
- **True modularity** – *utilises Q-Series base and seat components for easier ordering & fleet maintenance*
- **Exceptional ride comfort** – *from the advanced dynamic suspension*
- **Effective obstacle climbing** – *up to 85mm without needing a kerb climber*
- **SEDEO PRO seat** - *modular, easy to adjust and quickly adaptable to changing user needs*



Q500 H
SEDEO PRO

***A NEW GENERATION
OF POWERCHAIR***